

(*) Aggregate Base shall extend to edge of ditch and planed on Separator Fabric for Bases.

TYPICAL SECTION
LOCAL RESIDENTIAL RURAL ROADWAY
R-A and R-A2 Zoning Districts
• 100 •

LEGEND	
	S5 (PG 64-22 OK)
	S3 (PG 58-28 OK)
	P.C. Concrete
	Stabilized Subgrade or Type A Aggregate Base
	Type A Aggregate Base (95% SPD Compaction)
	Compacted Subgrade
	Backfill
	Sodding
	Cement Treated Base or S3 (PG 58-28 OK)
	Leveling Course

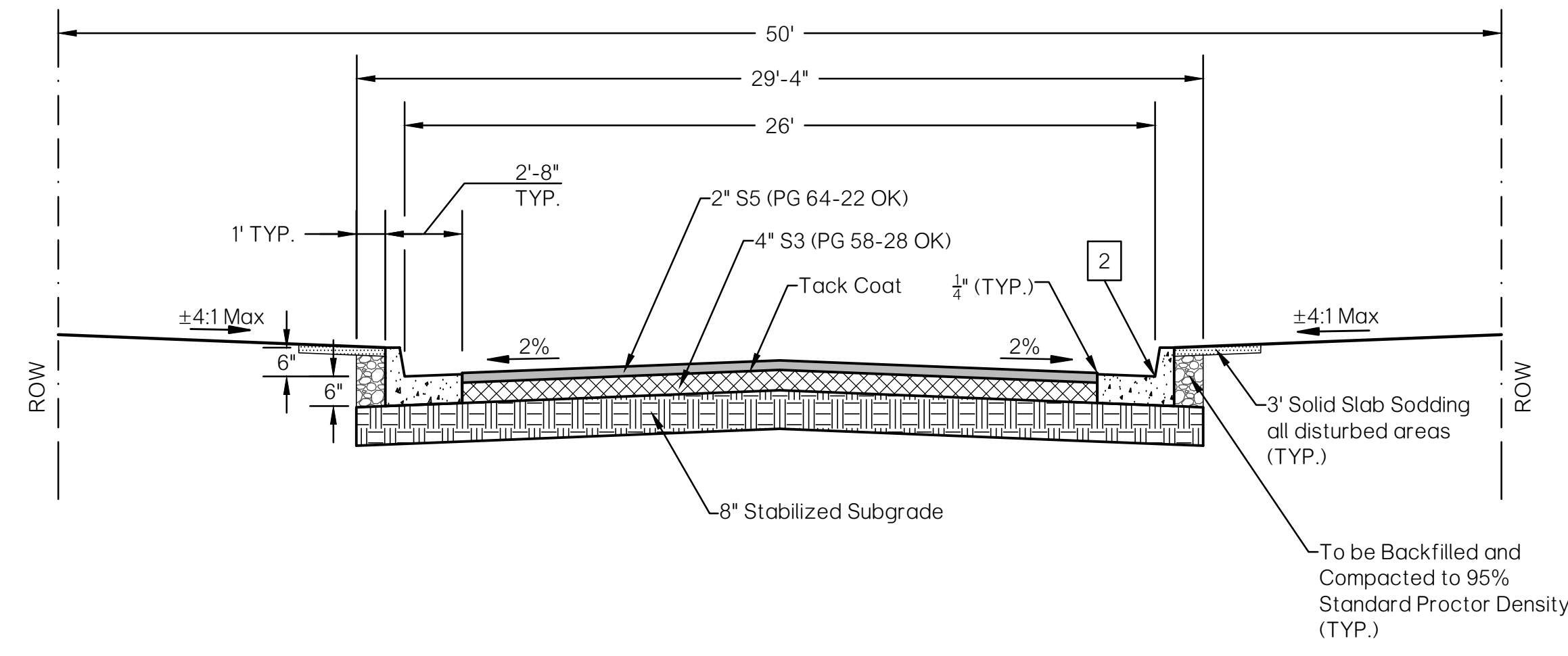

TYPICAL SECTION
26' HOT MIX ASPHALT PAVING
(STABILIZED SUBGRADE)
LOCAL RESIDENTIAL
• 101 •

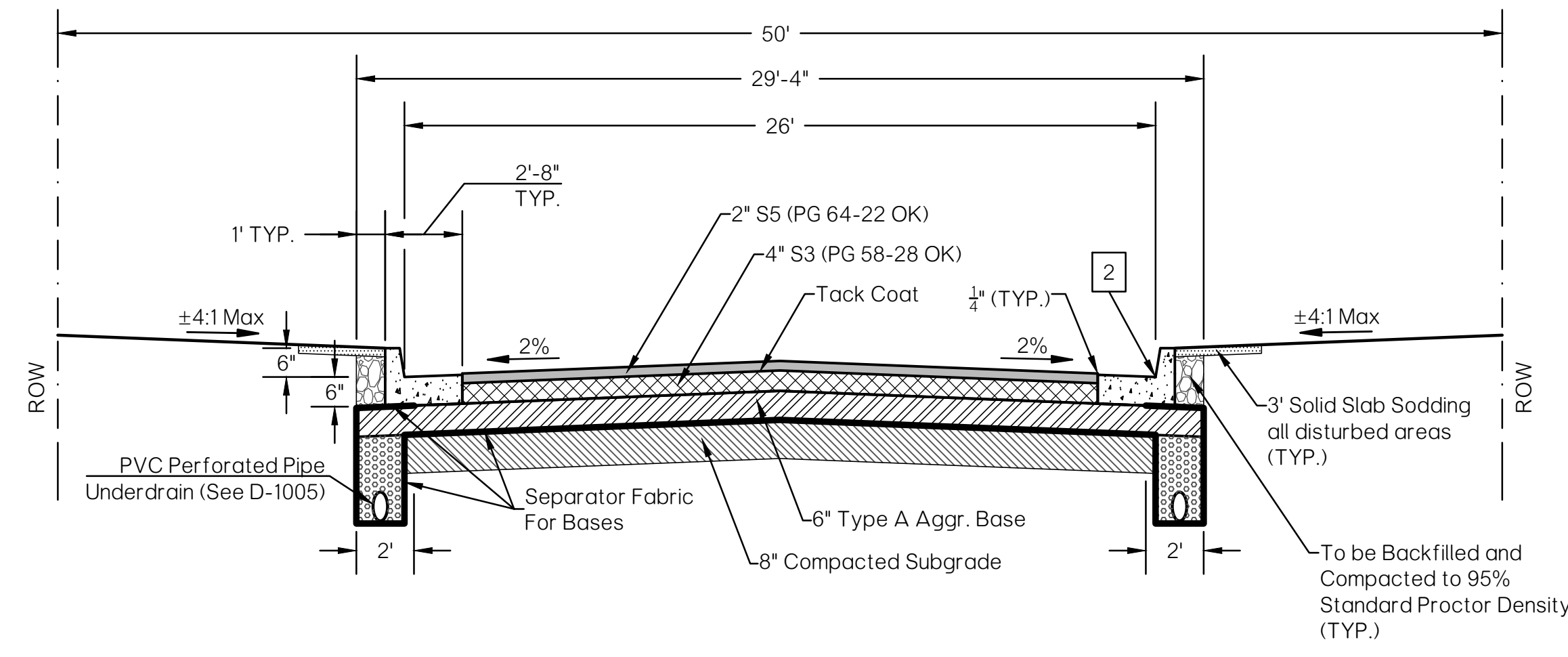

NOTE: Edge Drain Location to be Determined by the City Engineer. Refer to Pavement Edge Drain Sheet for Details. (See Detail Number D-1005.)

- 1 Ribbon Curb (See Detail D-200C)
- 2 Concrete Curb and Gutter Type 1, 2 or 3 (See Detail D-200C)

RESIDENTIAL ASPHALT NOTE:
1. S3 BASE COURSES SHALL USE BINDER GRADE PG 58-28 OK WITH A MAXIMUM OF 15% RECLAIMED ASPHALT PAVEMENT (RAP).
2. S5 SURFACE COURSE SHALL USE BINDER GRADE PG 64-22 OK WITH A VIRGIN MIX (NO RAP).
3. DESIGN MIXES, INCLUDING ACCEPTABLE TEST RESULTS, INDICATING A FINAL PERFORMANCE GRADE OF PG 64-22 OK MAY BE REQUIRED PRIOR TO APPROVAL OF A MIX FOR USE IN THE CITY OF OKLAHOMA CITY.

TYPICAL SECTION
26' HOT MIX ASPHALT PAVING
(AGGREGATE BASE)
LOCAL RESIDENTIAL
• 102 •

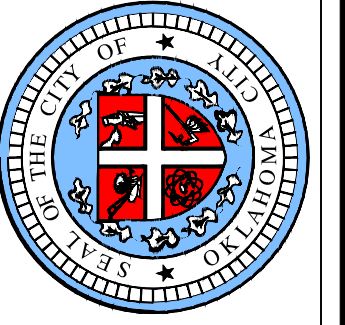

APPROVED BY:
ERIC J. WENGER, P.E.
CITY ENGINEER
DATE: 08/12/2023
DRAWN: OKC-PW-SRB
DATE: 3/9/2023

**STANDARD TYPICAL SECTIONS
ASPHALTIC PAVING**

Detail Number
D-100A

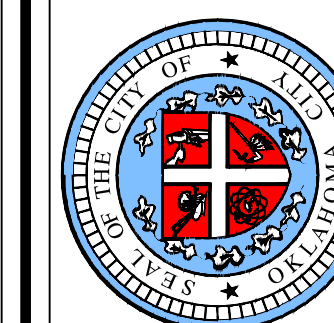

APPROVED BY:  DATE: 09/12/2023
 ERIC J. WENGER, P.E.
 CITY ENGINEER
 DRAWN: OKC-PW-SRB
 DATE: 3/9/2023

**STANDARD TYPICAL SECTIONS
 ASPHALTIC PAVING**

Detail Number
 D-100B

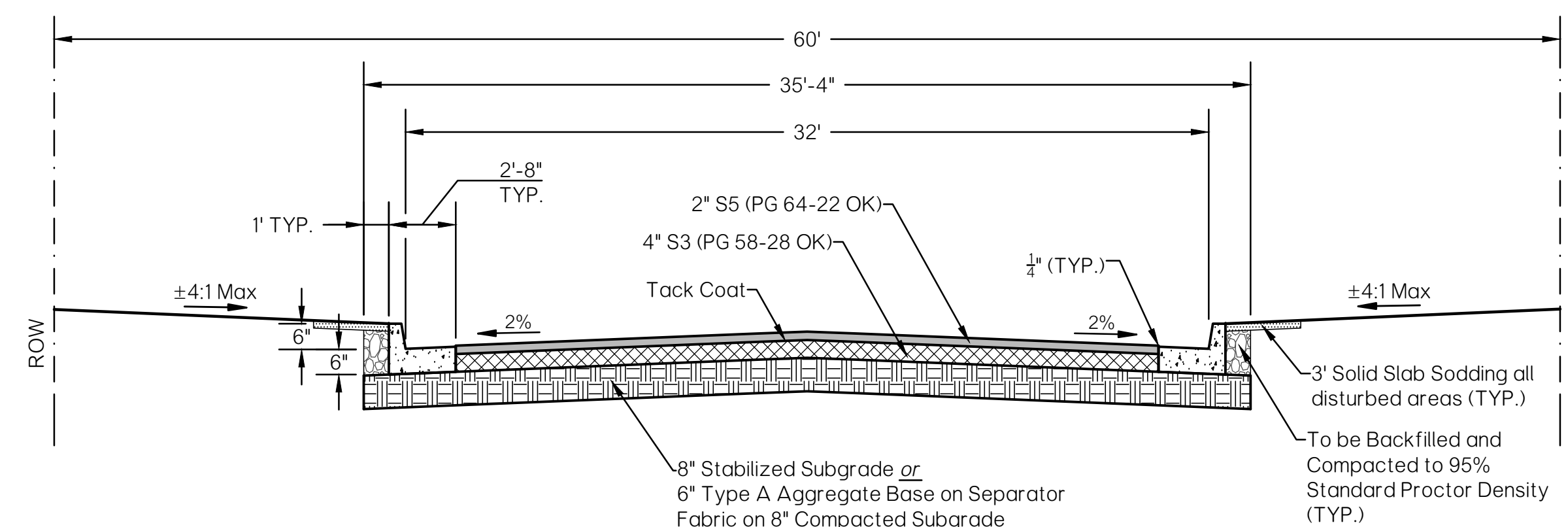

TYPICAL SECTION
 32' HOT MIX ASPHALT PAVING
 RESIDENTIAL COLLECTOR
 • 110 •

RESIDENTIAL TYPICAL NOTE:
 1. S3 BASE COURSES AND S5 SURFACE COURSES SHALL USE BINDER GRADE PG 58-28 OK WITH A MAXIMUM OF 15% RECLAIMED ASPHALT PAVEMENT (RAP).
 2. S5 SURFACE COURSE SHALL USE BINDER GRADE PG 64-22 OK WITH A VIRGIN MIX (NO RAP).
 3. COURSE DESIGN MIXES, INCLUDING ACCEPTABLE TEST RESULTS, INDICATING A FINAL PERFORMANCE GRADE OF PG 64-22 OK MAY BE REQUIRED PRIOR TO APPROVAL OF A MIX FOR USE IN THE CITY OF OKLAHOMA CITY.

LEGEND	
	S5 (PG 70-28 OK) or S5 (PG 64-22 OK)
	S3 (PG 64-22 OK) or S3 (PG 58-28 OK)
	S3 (PG 58-28 OK)
	P.C. Concrete
	Stabilized Subgrade or Type A Aggregate Base
	Type A Aggregate Base (95% SPD Compaction)
	Compacted Subgrade
	Backfill
	Sodding
	Cement Treated Base or S3 (PG 58-28 OK)
	Leveling Course

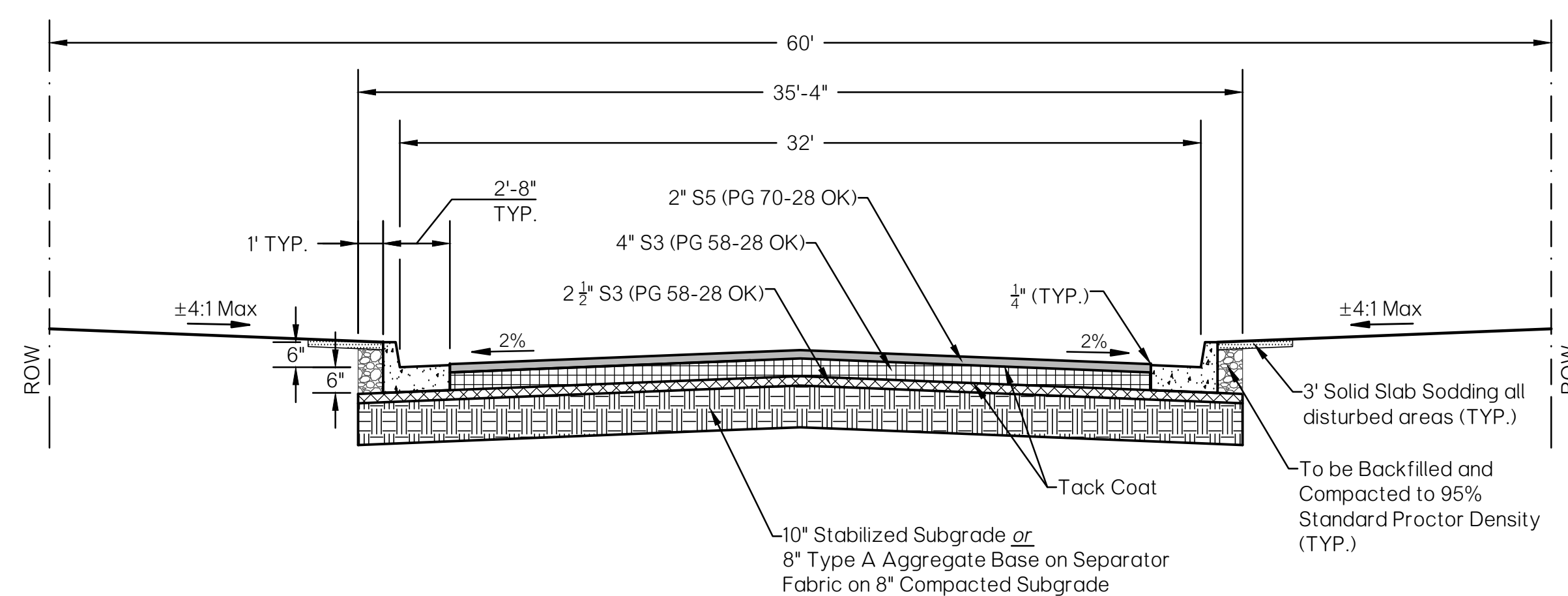

TYPICAL SECTION
 32' HOT MIX ASPHALT PAVING
 COMMERCIAL
 • 111 •

COMMERCIAL/INDUSTRIAL TYPICAL NOTE:
 1. S3 BASE COURSES SHALL USE BINDER GRADE PG 58-28 OK WITH A MAXIMUM OF 15% RECLAIMED ASPHALT PAVEMENT (RAP).
 2. S5 SURFACE COURSE SHALL USE BINDER GRADE PG 70-28 OK WITH A VIRGIN MIX (NO RAP).
 3. COURSE DESIGN MIXES, INCLUDING ACCEPTABLE TEST RESULTS, INDICATING A FINAL PERFORMANCE GRADE OF PG 64-22 OK MAY BE REQUIRED PRIOR TO APPROVAL OF A MIX FOR USE IN THE CITY OF OKLAHOMA CITY.

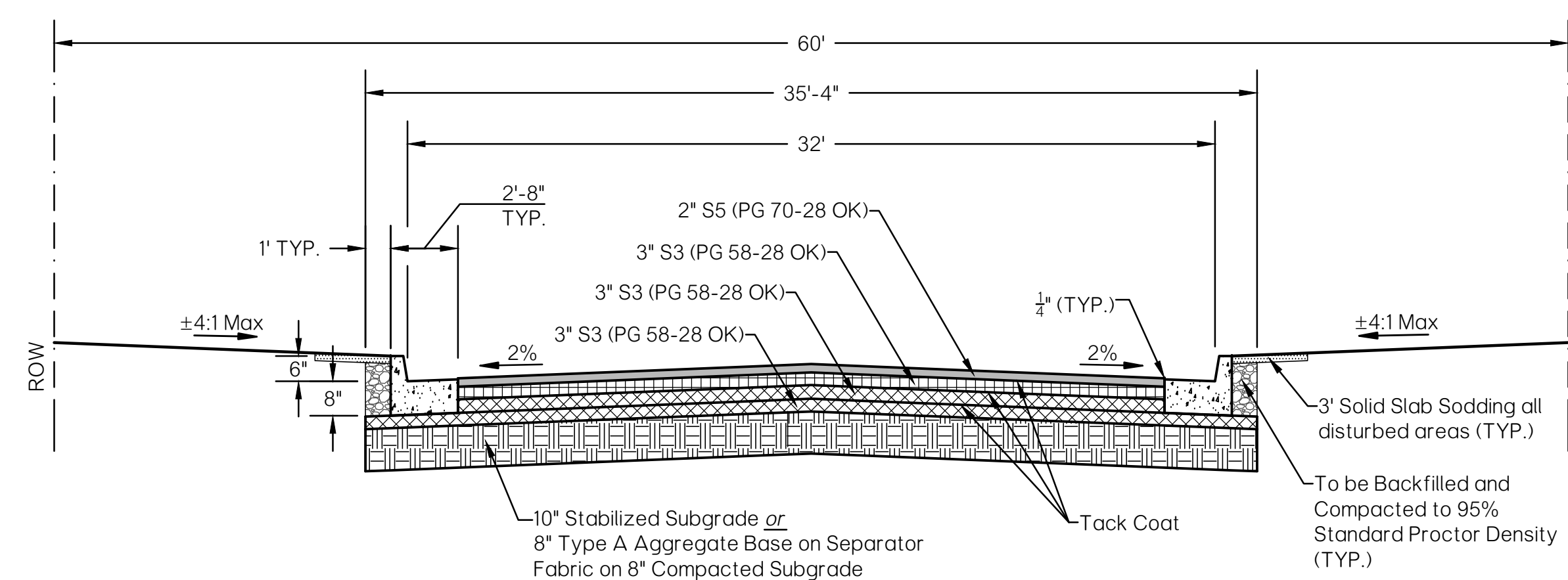

TYPICAL SECTION
 32' HOT MIX ASPHALT PAVING
 INDUSTRIAL
 • 112 •

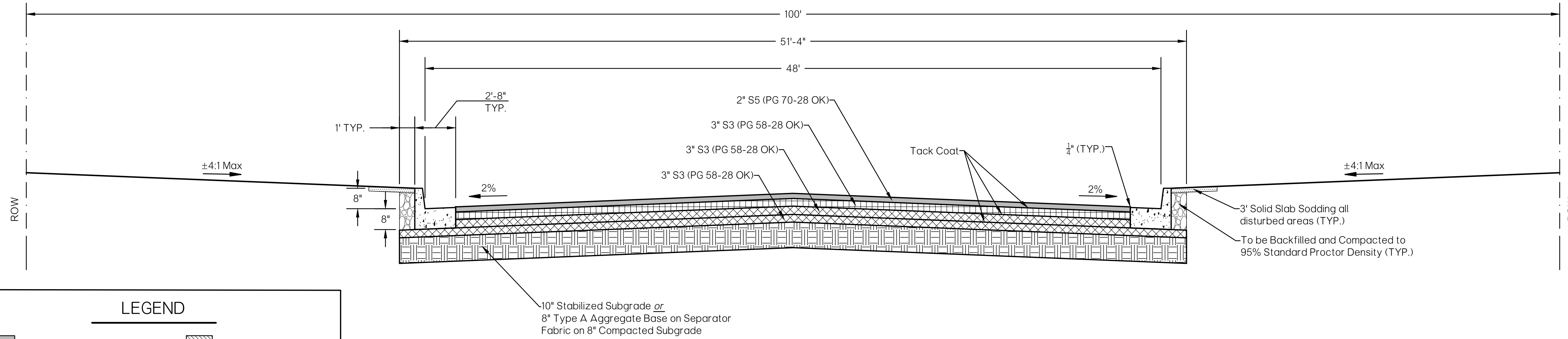

TYPICAL SECTION
48' HOT MIX ASPHALT PAVING
ARTERIAL
• 120 •

LEGEND			
	S5 (PG 70-28 OK)		Compacted Subgrade
	S3 (PG 64-22 OK) or S3 (PG 58-28 OK)		Backfill
	S3 (PG 58-28 OK)		Sodding
	P.C. Concrete		Cement Treated Base or S3 (PG 58-28 OK)
	Stabilized Subgrade or Type A Aggregate Base		Leveling Course
	Type A Aggregate Base (95% SPD Compaction)		

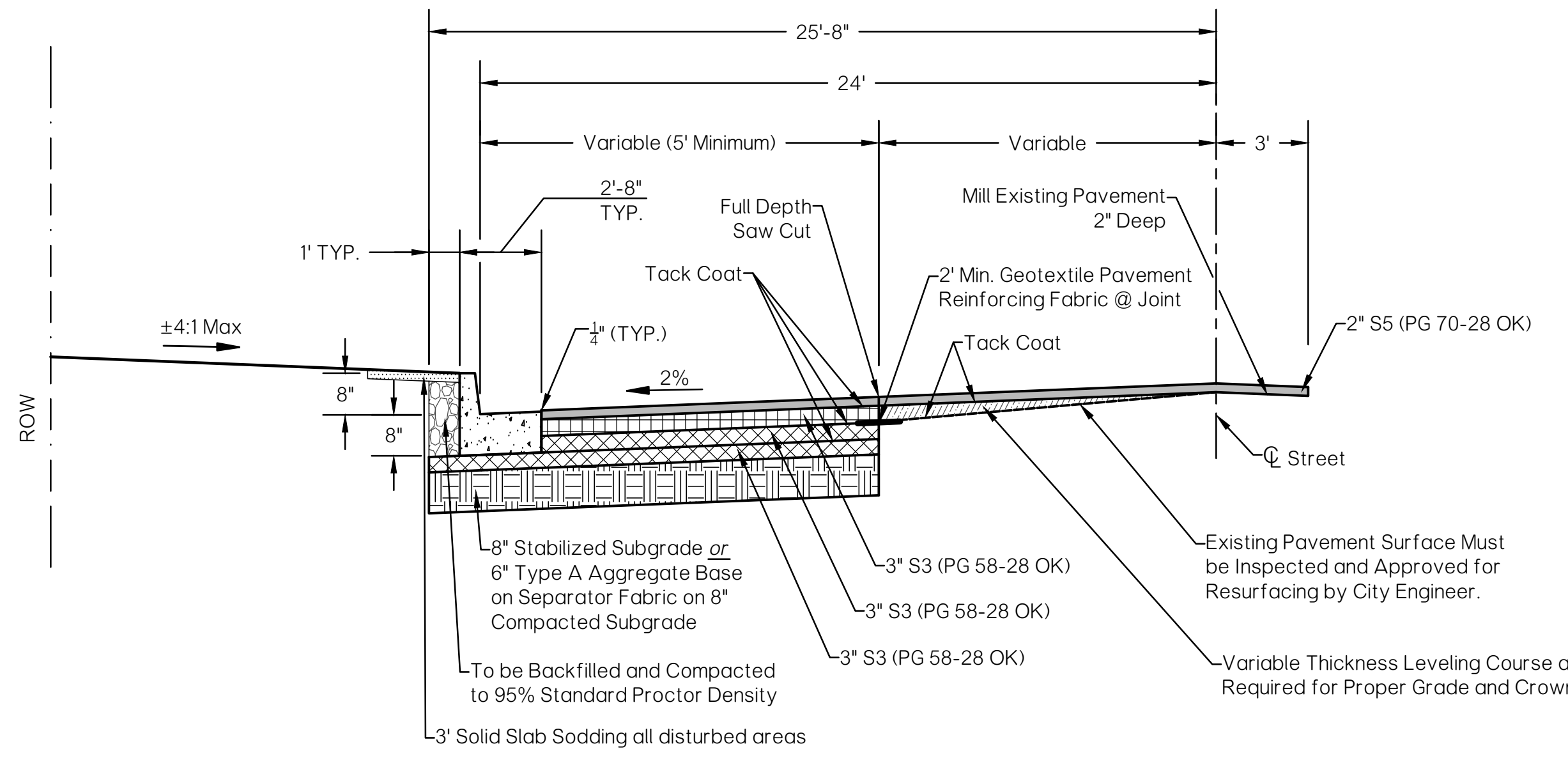

TYPICAL SECTION
VARIABLE WIDENING HOT MIX ASPHALT PAVING
• 130 •

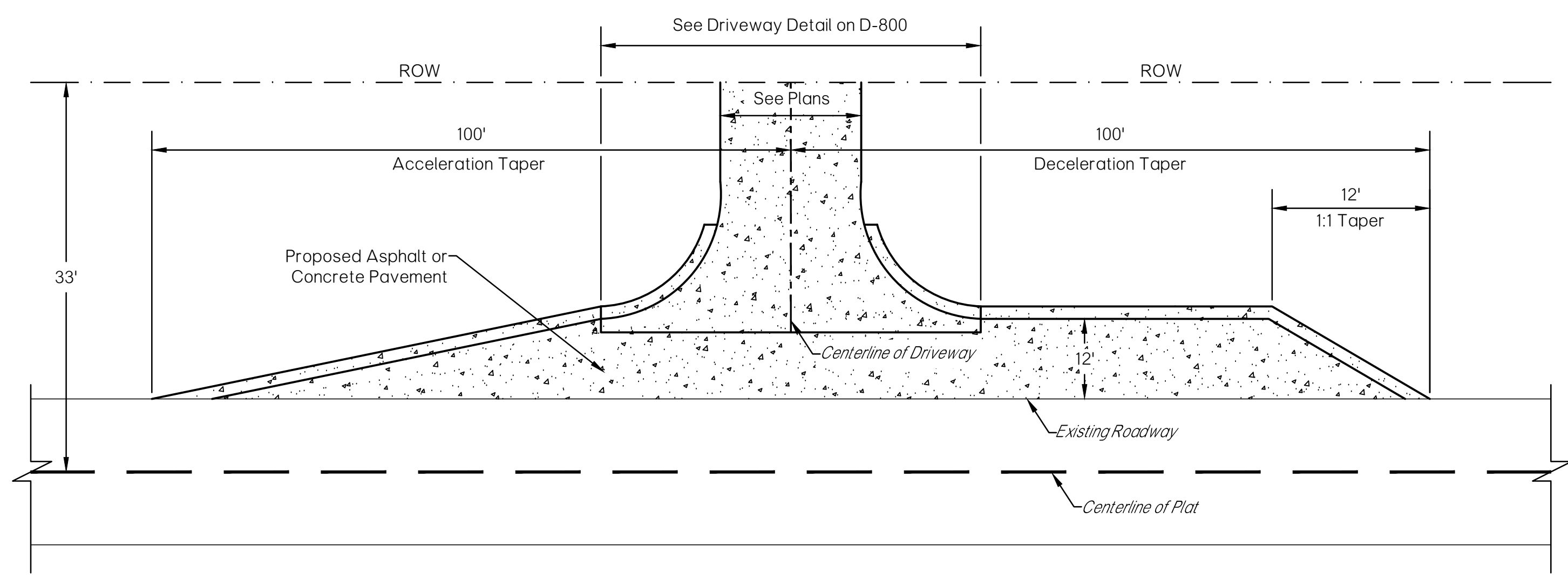

TYPICAL SECTION
RURAL 2-LANE DRIVEWAY ACCESS
• 140 •

ARTERIAL/WIDENING TYPICAL NOTE:
1. S3 BASE COURSES SHALL USE BINDER GRADE PG 58-28 OK WITH A MAXIMUM OF 15% RECLAIMED ASPHALT PAVEMENT (RAP).
2. S5 SURFACE COURSE SHALL USE BINDER GRADE PG 70-28 OK WITH A VIRGIN MIX (NO RAP).
3. COURSE DESIGN MIXES, INCLUDING ACCEPTABLE TEST RESULTS, INDICATING A FINAL PERFORMANCE GRADE OF PG 64-22 OK MAY BE REQUIRED PRIOR TO APPROVAL OF A MIX FOR USE IN THE CITY OF OKLAHOMA CITY.

The City of
Oklahoma City
Public Works Department
Engineering Division

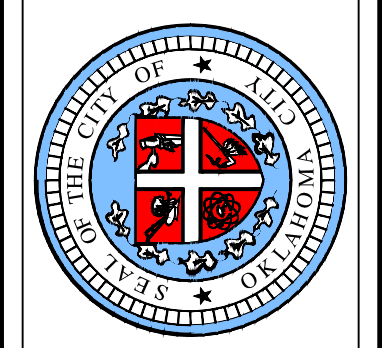

APPROVED BY:
ERIC J. WENGER, P.E.
CITY ENGINEER
DATE: 09/12/2023
DRAWN: OKC-PW-SRB
DATE: 3/9/2023

**STANDARD TYPICAL SECTIONS
ASPHALTIC PAVING**

Detail Number
D-100C

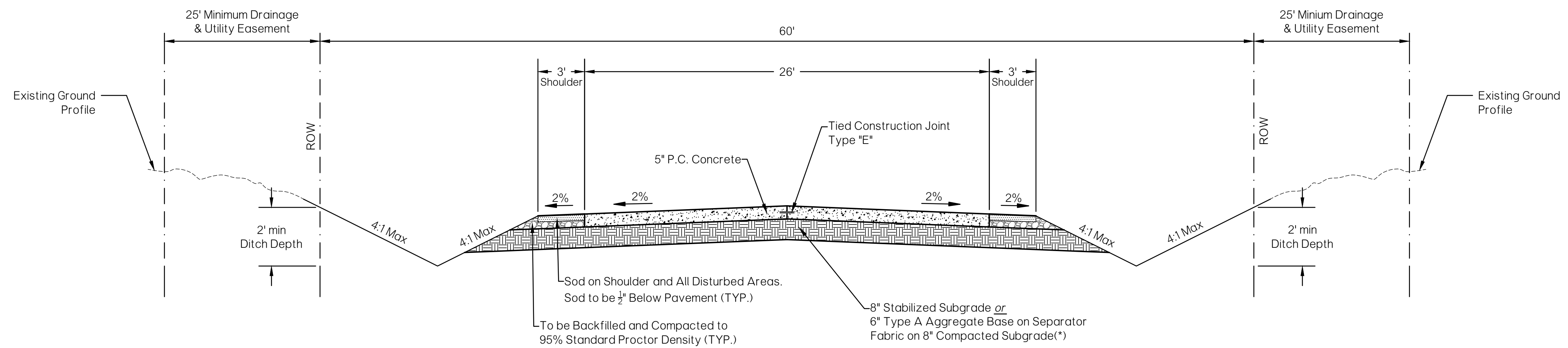

(*) Aggregate Base shall extend to edge of ditch and planed on Separator Fabric for Bases.

LEGEND	
	S5 (PG 70-28 OK) or S5 (PG 64-22 OK)
	S3 (PG 58-28 OK)
	P.C. Concrete
	Stabilized Subgrade or Type A Aggregate Base
	Type A Aggregate Base (95% SPD Compaction)
	Compacted Subgrade
	Backfill
	Sodding
	Cement Treated Base or S3 (PG 58-28 OK)
	Leveling Course

TYPICAL SECTION
LOCAL RESIDENTIAL RURAL ROADWAY
R-A and R-A2 Zoning Districts
• 200 •

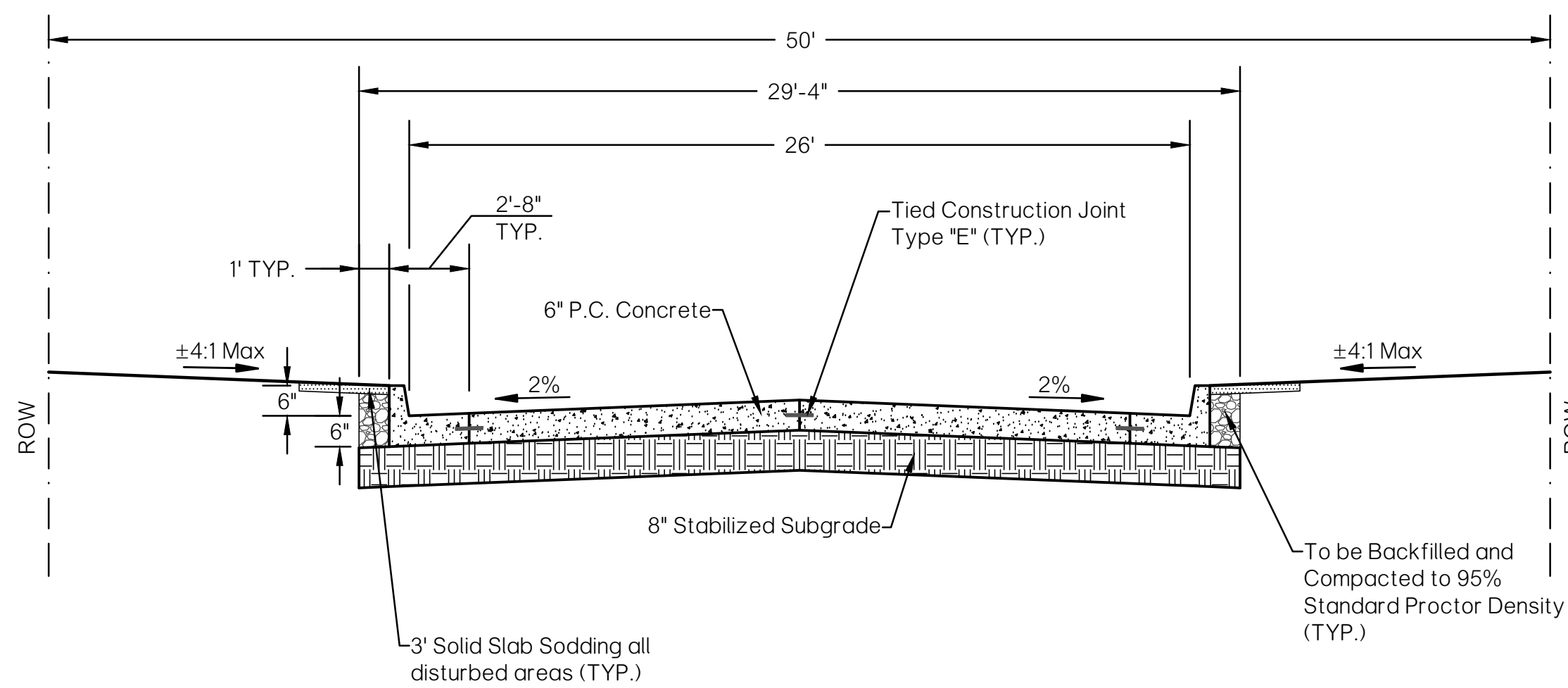

TYPICAL SECTION
26' P.C. CONCRETE PAVING
(STABILIZED SUBGRADE)
LOCAL RESIDENTIAL
• 201 •

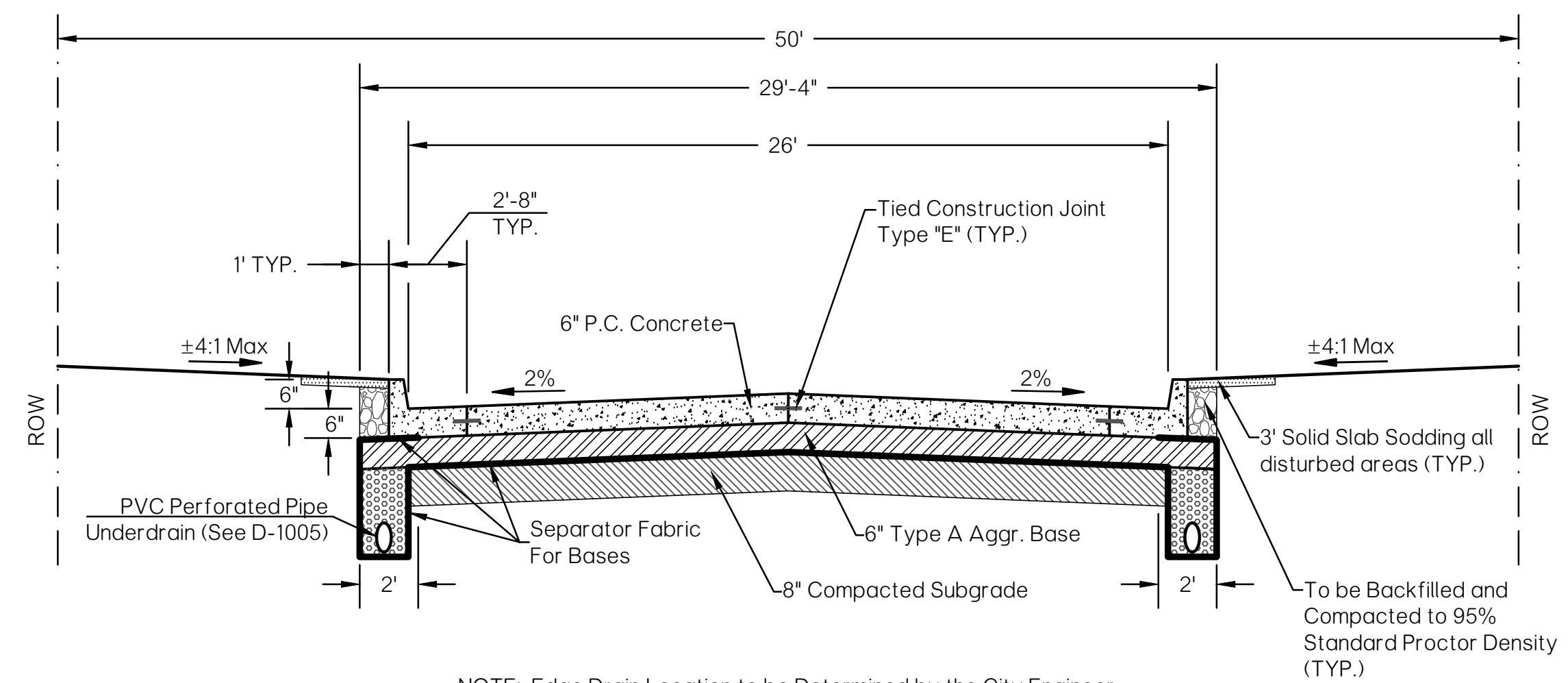

NOTE: Edge Drain Location to be Determined by the City Engineer.
Refer to Pavement Edge Drain Sheet for Details.
(See Detail Number D-1005.)

TYPICAL SECTION
26' P.C. CONCRETE PAVING
(AGGREGATE BASE)
LOCAL RESIDENTIAL
• 202 •

The City of
Oklahoma City
Public Works Department
Engineering Division

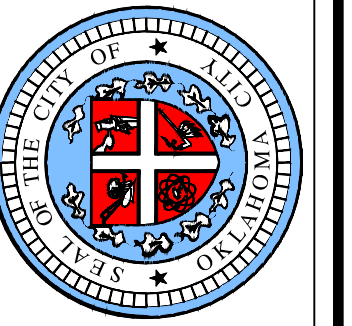

APPROVED BY:
ERIC J. WENGER, P.E.
CITY ENGINEER
DATE: 09/12/2023
DRAWN: OKC-PW-SRB
DATE: 3/9/2023

STANDARD TYPICAL SECTIONS
P.C. CONCRETE PAVING

Detail Number
D-200A

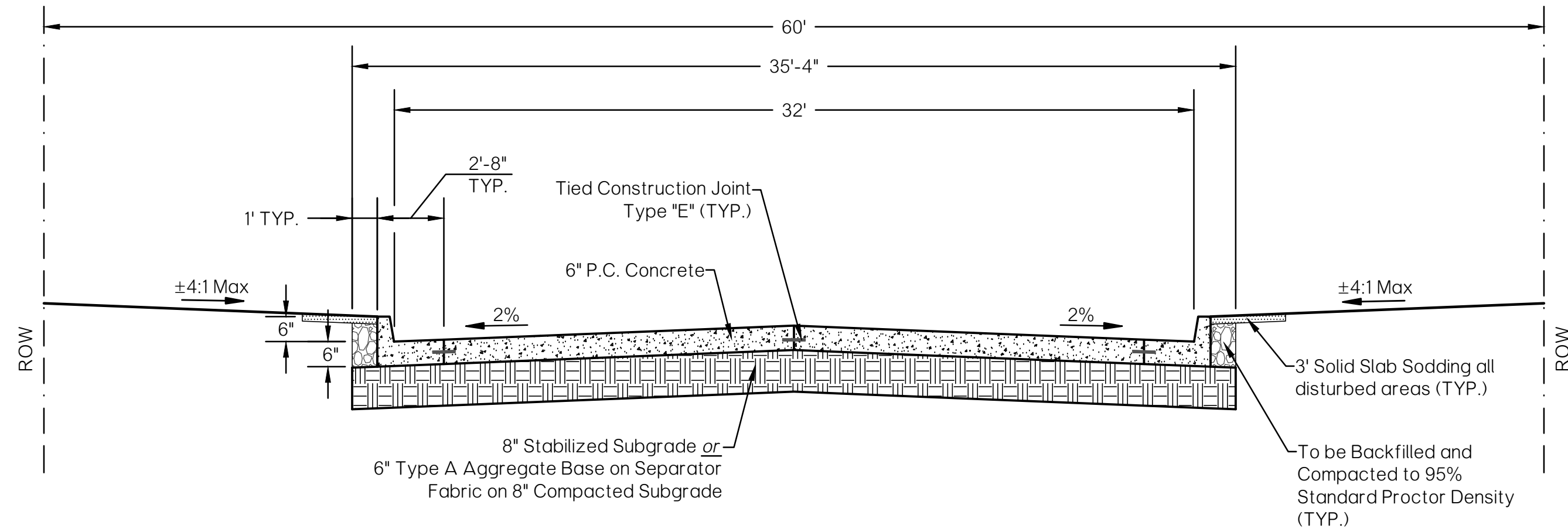

TYPICAL SECTION
32' P.C. CONCRETE PAVING
RESIDENTIAL COLLECTOR
• 210 •

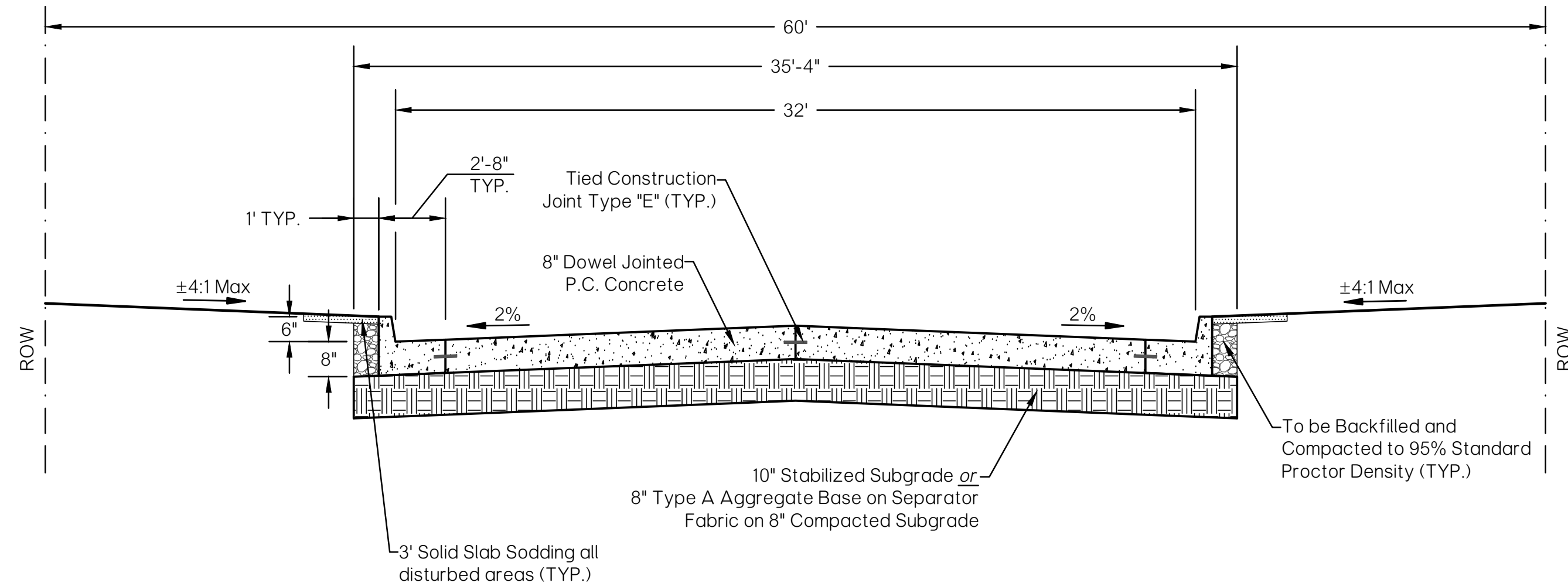

TYPICAL SECTION
32' P.C. CONCRETE PAVING
COMMERCIAL
• 211 •

LEGEND	
	S5 (PG 70-28 OK) or S5 (PG 64-22 OK)
	S3 (PG 58-28 OK)
	P.C. Concrete
	Stabilized Subgrade or Type A Aggregate Base
	Type A Aggregate Base (95% SPD Compaction)
	Compacted Subgrade
	Backfill
	Sodding
	Cement Treated Base or S3 (PG 58-28 OK)
	Leveling Course

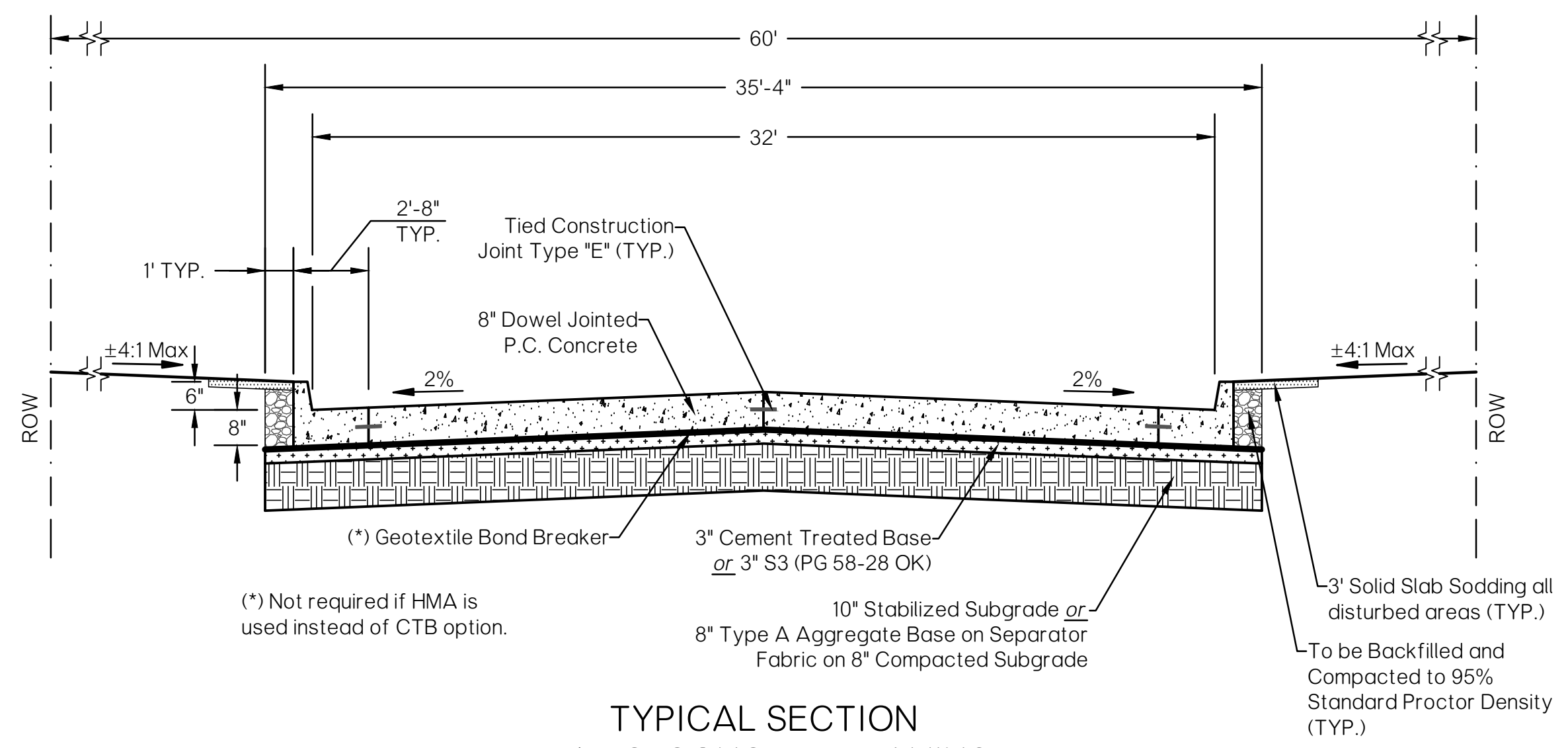

TYPICAL SECTION
32' P.C. CONCRETE PAVING
INDUSTRIAL
• 212 •

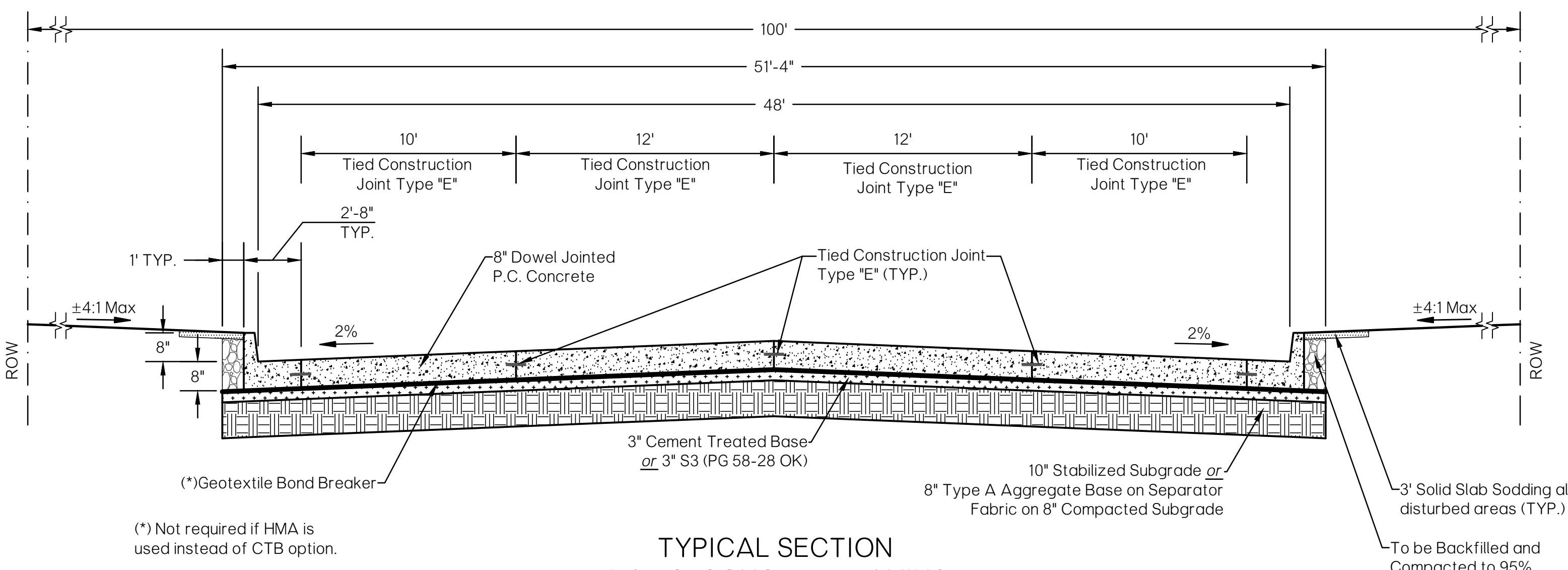

TYPICAL SECTION
48' P.C. CONCRETE PAVING
ARTERIAL
• 220 •

The City of
Oklahoma City
Public Works Department
Engineering Division

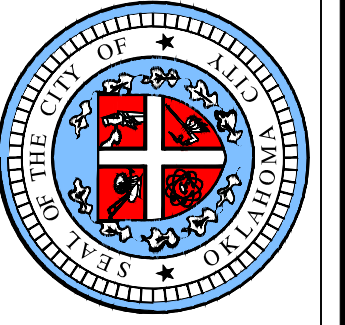

APPROVED BY:
ERIC J. WENGER, P.E.
CITY ENGINEER
DATE: 09/12/2023
DRAWN: OKC-PW-SRB
DATE: 3/9/2023

**STANDARD TYPICAL SECTIONS
P.C. CONCRETE PAVING**

Detail Number
D-200B

C:\Users\comor.holland\OneDrive - City of Oklahoma City\Projects\Active\Standard Details\C3D\Drawings\D-200_DRAFT.dwg, 6/9/2026 8:07:19 AM

	Up to 33' (Residential Streets)	32' and over (Thoroughfare Streets)
A	6"	8"
B	6"	8"

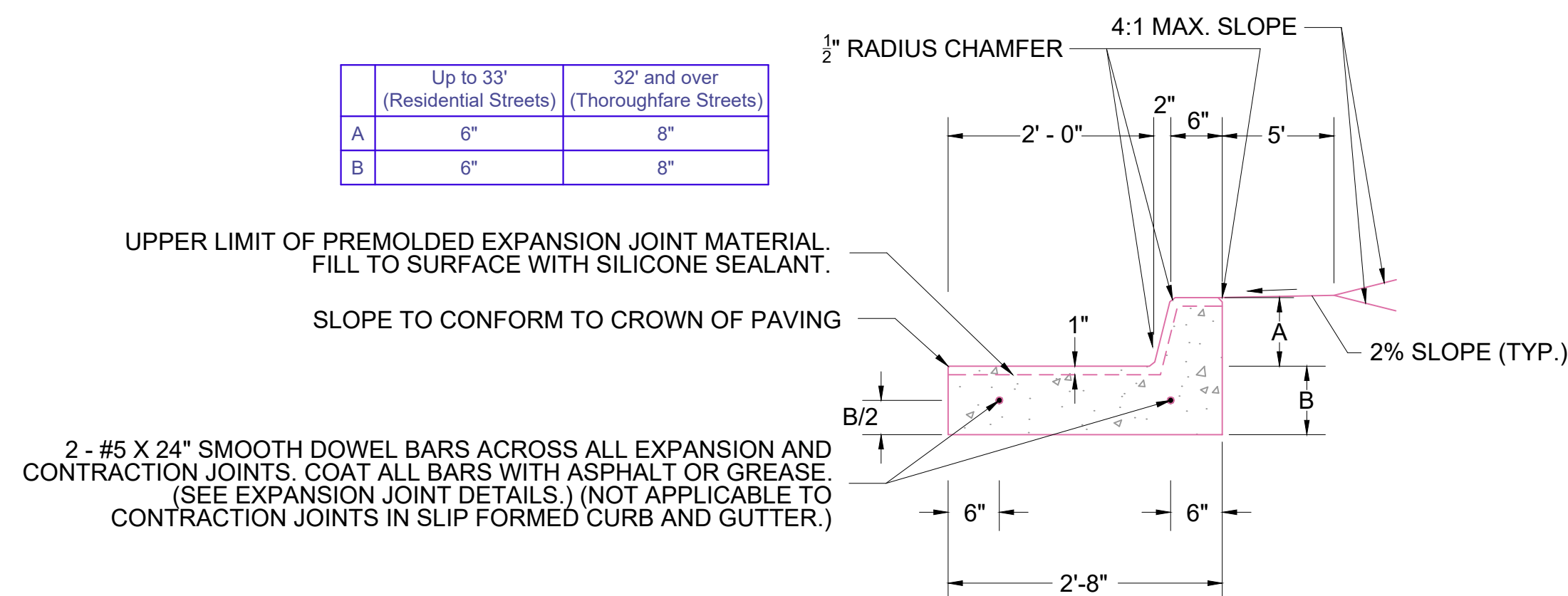

NOTE: MAXIMUM SPACING OF 1/2" EXPANSION JOINTS TO BE 200' C/C WITH CONTRACTION JOINTS 15' - 20' APART TO MATCH DRIVEWAY RETURNS. (EXPANSION JOINT SPACING, NOT APPLICABLE TO SLIP FORMED CURB AND GUTTER.)

**BARRIER CURB & GUTTER DETAIL
TYPE 1**

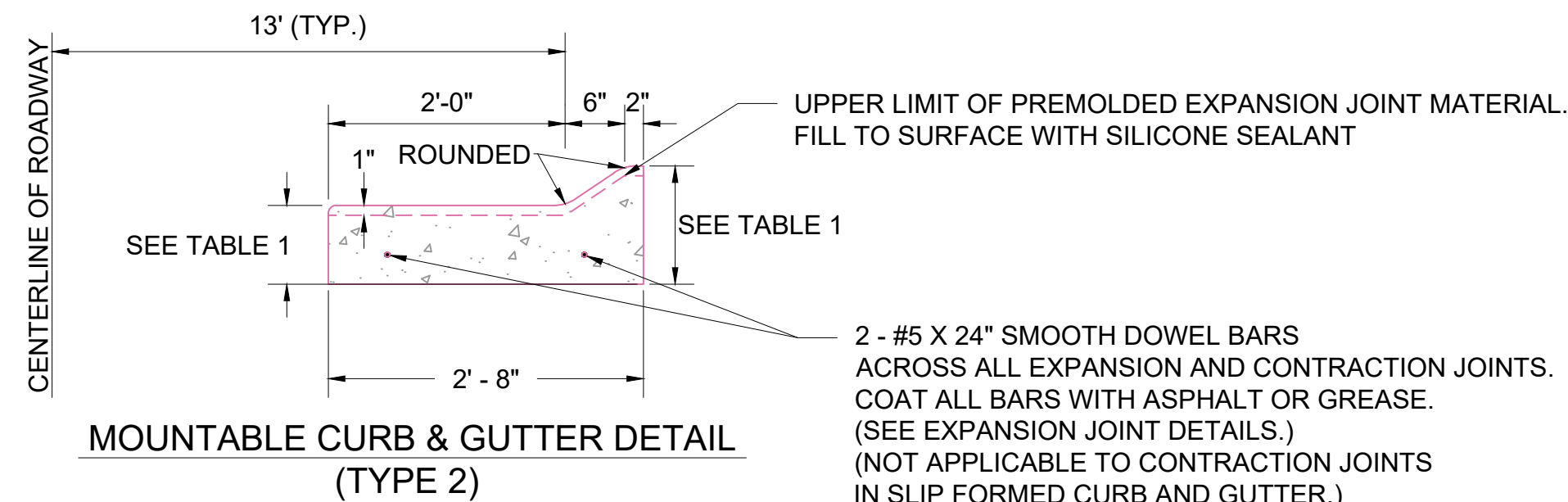

**MOUNTABLE CURB & GUTTER DETAIL
(TYPE 2)**

* FOR USE IN RESIDENTIAL STREET ONLY, UNLESS OTHERWISE APPROVED BY CITY ENGINEER

GUTTER THICKNESS	CURB HEIGHT	BACK OF CURB HEIGHT
6"	4"	10"
6"	6" *	12"

* NOT ALLOWED IN TYPE 2

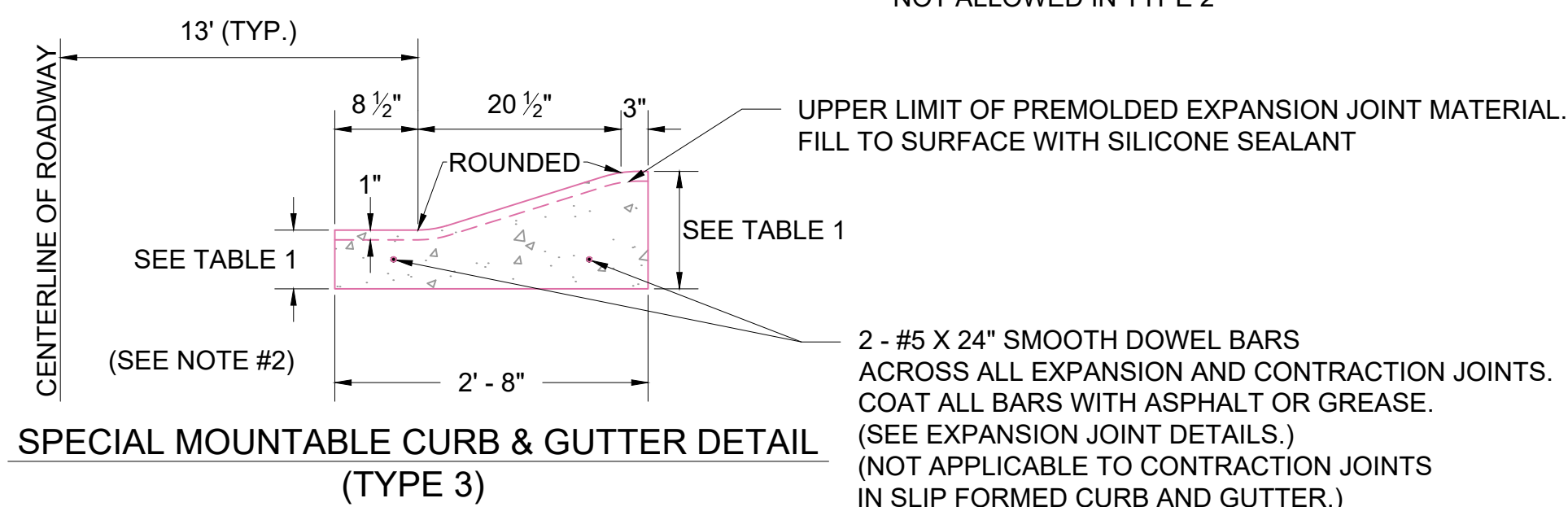

**SPECIAL MOUNTABLE CURB & GUTTER DETAIL
(TYPE 3)**

* FOR USE IN RESIDENTIAL STREET ONLY, UNLESS OTHERWISE APPROVED BY CITY ENGINEER

UPPER LIMIT OF PREMOLDED EXPANSION JOINT MATERIAL. FILL TO SURFACE WITH SILICONE SEALANT.

2 - #5 X 24" SMOOTH DOWEL BARS ACROSS ALL EXPANSION AND CONTRACTION JOINTS. COAT ALL BARS WITH ASPHALT OR GREASE. (SEE EXPANSION JOINT DETAILS.) (NOT APPLICABLE TO CONTRACTION JOINTS IN SLIP FORMED CURB AND GUTTER.)

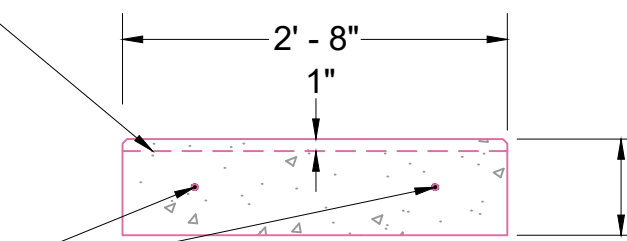

**RIBBON CURB DETAIL
(TYPE 4)**

* FOR USE IN RESIDENTIAL STREET ONLY

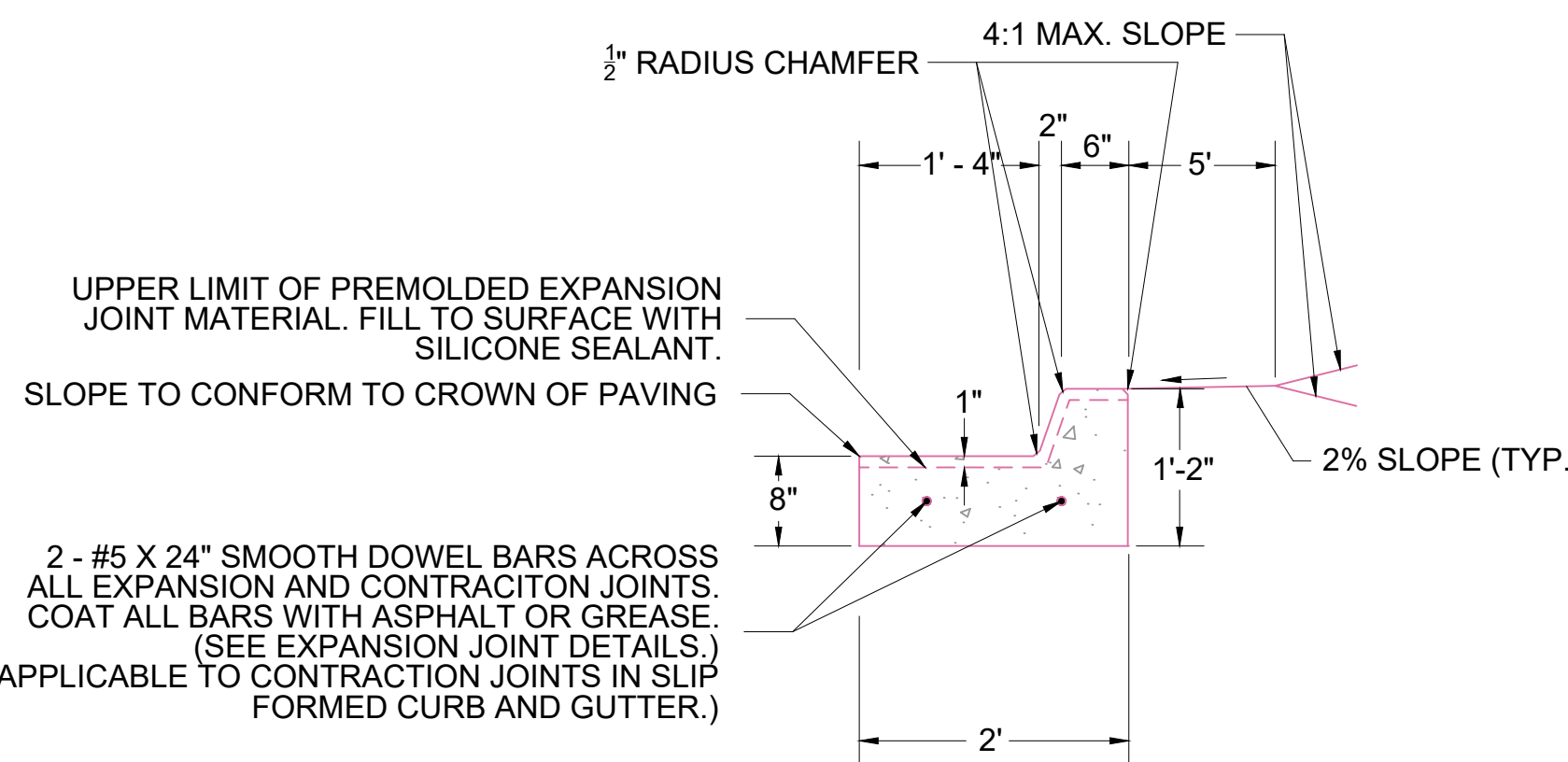

UPPER LIMIT OF PREMOLDED EXPANSION JOINT MATERIAL. FILL TO SURFACE WITH SILICONE SEALANT. SLOPE TO CONFORM TO CROWN OF PAVING

2 - #5 X 24" SMOOTH DOWEL BARS ACROSS ALL EXPANSION AND CONTRACTION JOINTS. COAT ALL BARS WITH ASPHALT OR GREASE. (SEE EXPANSION JOINT DETAILS.) (NOT APPLICABLE TO CONTRACTION JOINTS IN SLIP FORMED CURB AND GUTTER.)

NOTE: MAXIMUM SPACING OF 1/2" EXPANSION JOINTS TO BE 200' C/C WITH CONTRACTION JOINTS 15' - 20' APART TO MATCH DRIVEWAY RETURNS. (EXPANSION JOINT SPACING, NOT APPLICABLE TO SLIP FORMED CURB AND GUTTER.)

**CONCRETE CURB & GUTTER DETAIL FOR DOWNTOWN
(TYPE 5)**

EXPLANATION OF DIMENSIONS
TOP DIMENSION - R-3262-3
BOTTOM DIMENSION - R-3262-6

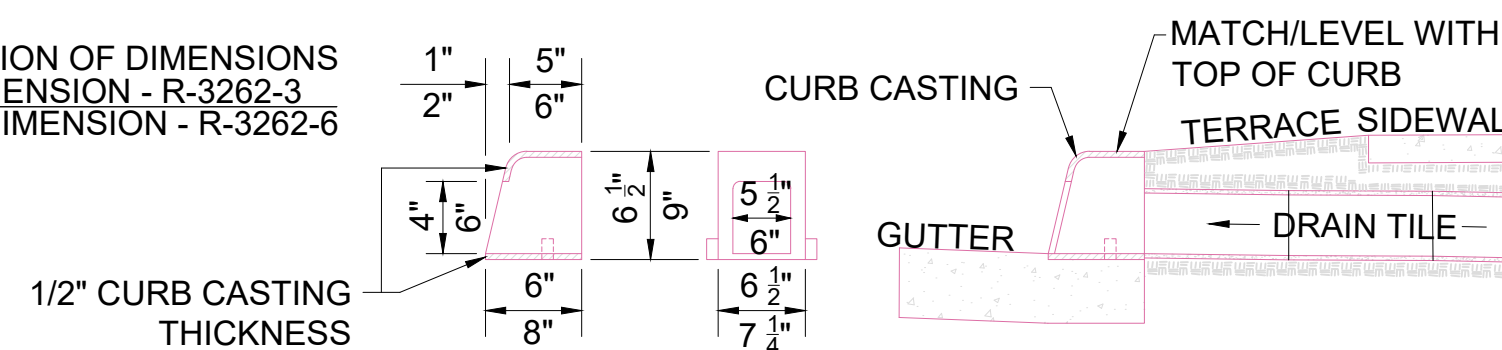

**STORM WATER CURB OPENINGS
NEENAH R-3262-3 & R-3262-6**

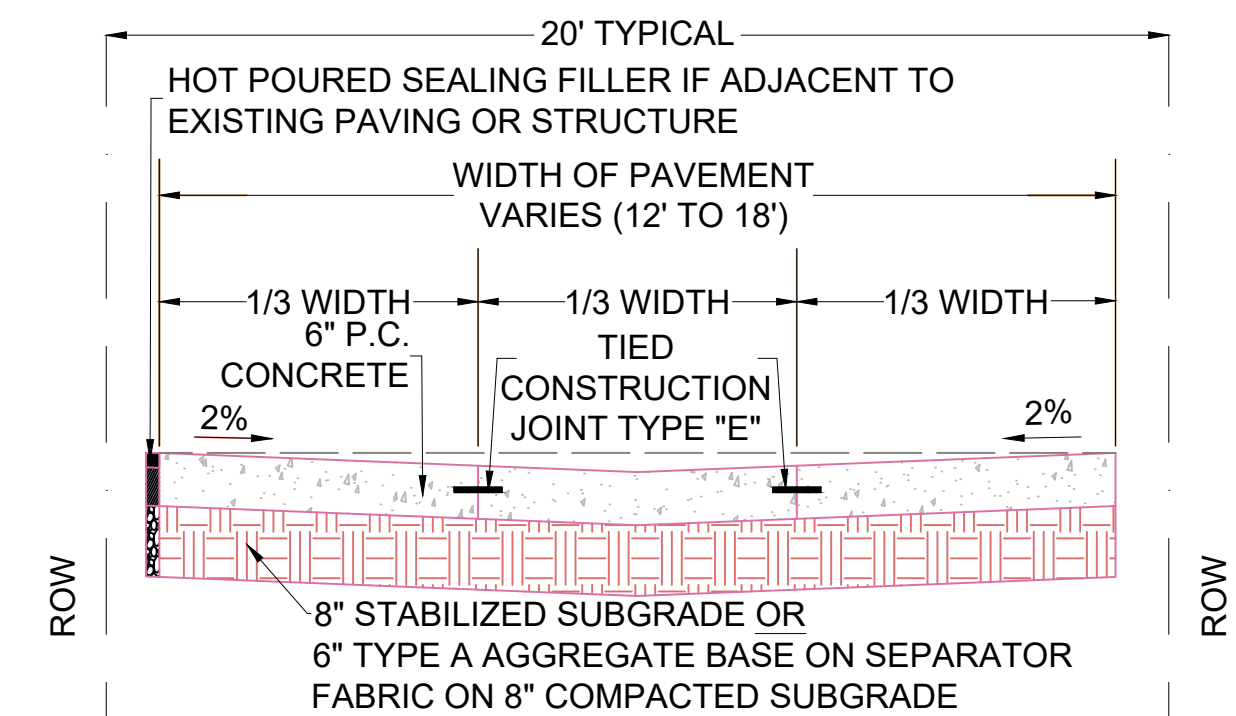

**TYPICAL SECTION
P.C. CONCRETE ALLEY PAVING
(STABILIZED SUBGRADE)
LOCAL RESIDENTIAL**

NOTE: TRANSVERSE JOINTS AT 10' MAX.

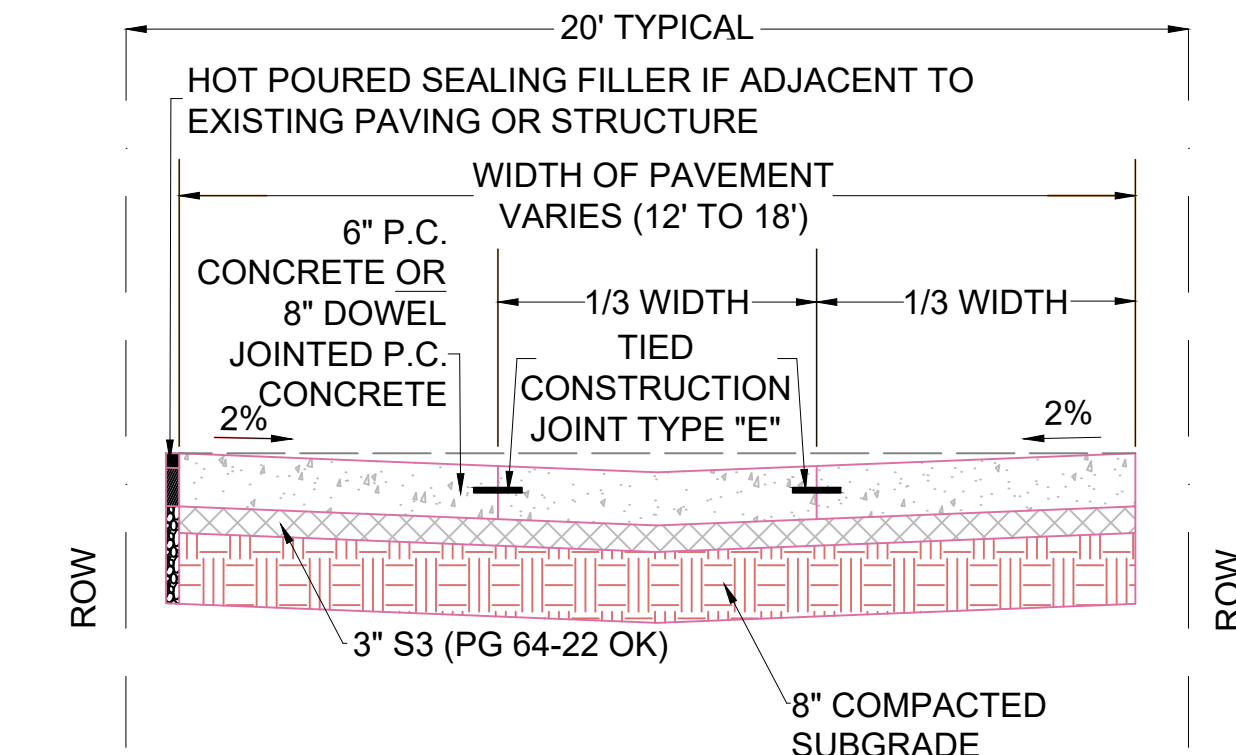

**TYPICAL SECTION
P.C. CONCRETE ALLEY PAVING
(ASPHALT BASE)
COMMERCIAL/INDUSTRIAL**

NOTE: TRANSVERSE JOINTS AT 10' MAX.

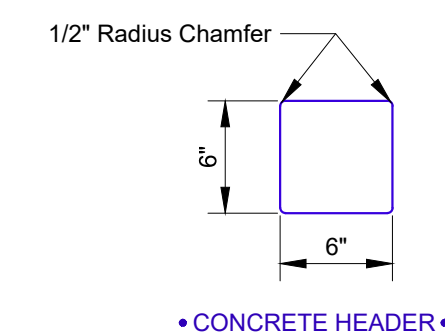

CURBS FOR P.C. CONCRETE PAVEMENT NOTES:

- #5 TIEBARS 2'-6" LONG ARE REQUIRED AT 24" CENTERS IF CURB & GUTTER NOT CAST INTEGRALLY WITH THE P.C. CONCRETE STREET PAVEMENT LONGITUDINAL CONSTRUCTION JOINTS ON LOCAL AND COLLECTOR STREETS MAY, WITH THE APPROVAL OF THE CITY ENGINEER, BE BUTT TYPE JOINTS WITH TIEBARS.
- WHEN CONNECTING NEW CONCRETE TO EXISTING CONCRETE A TIEBAR MUST BE USED USING EPOXY IN THE EXISTING CONCRETE.

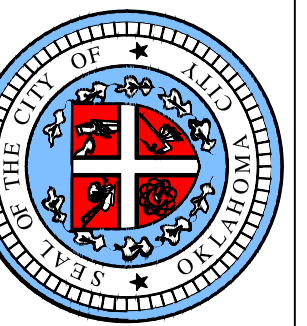

APPROVED BY: *Debbie Miller* DATE: 6/15/26
CITY ENGINEER

DRAWN: CH DATE: 06-09-26

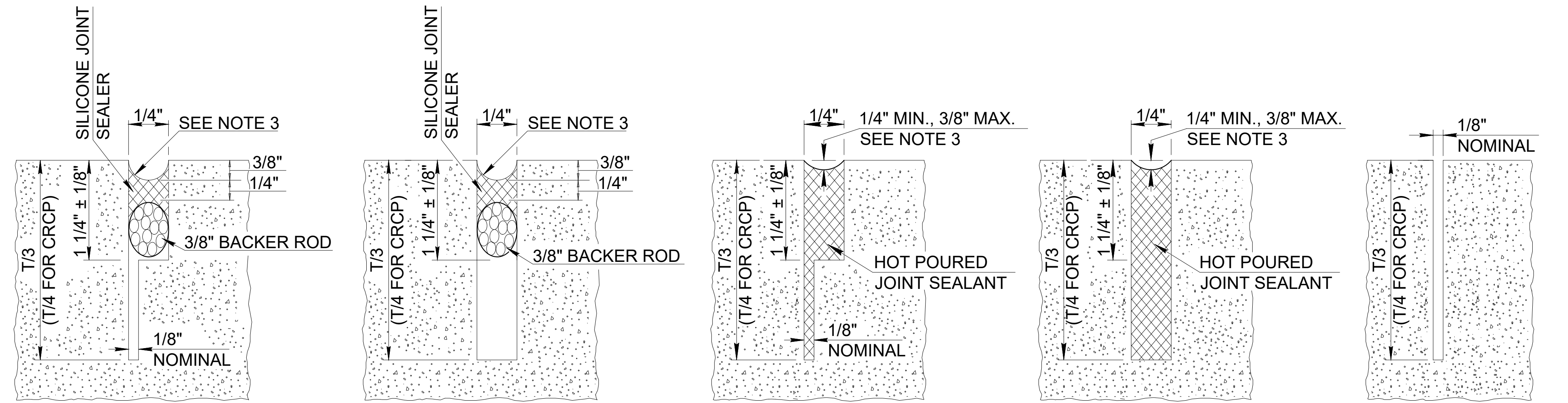

SILICONE SEALANT OPTION SILICONE SEALANT OPTION HOT POUR OPTION HOT POUR OPTION NO SEALANT OPTION
 SAWED AND SEALED, CONTRACTION AND LONGITUDINAL JOINTS ALTERNATE DETAILS

UNLESS OTHERWISE SPECIFIED, ONLY THE SILICONE SEALANT OPTIONS WILL BE ALLOWED.

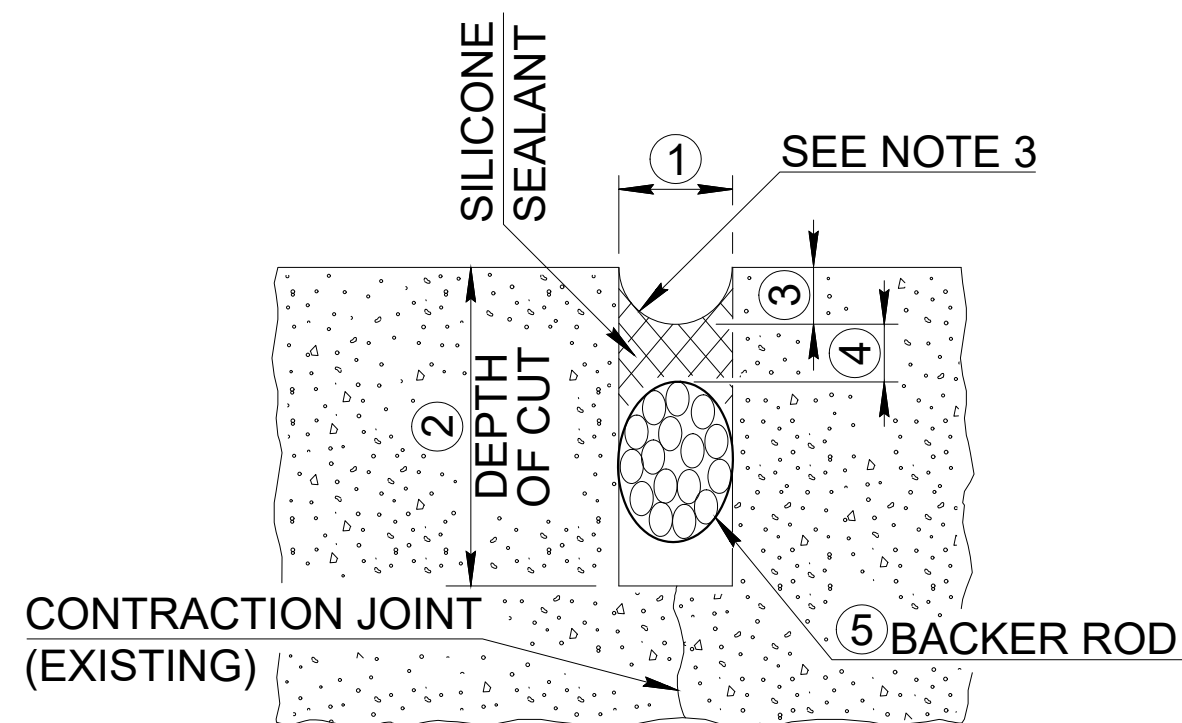

JOINT REHABILITATION DETAILS

JOINT REHABILITATION TREATMENT TABLE				
SILICONE SEALANT				
JOINT WIDTH	DEPTH OF CUT	SEALANT RECESS DEPTH	SEALANT THICKNESS	BACKER ROD DIAMETER
①	②	③	④	⑤
3/8"	1 1/4"	3/8"	3/16"	1/2"
1/2"	1 3/4"	3/8"	1/4"	5/8"
3/4"	1 3/4"	3/8"	3/8"	7/8"
7/8"	1 3/4"	1/2"	7/16"	1"
1"	2"	1/2"	1/2"	1 1/8"
OVER 1"	OVER 2"	1/2"	1/2"	1 1/4"

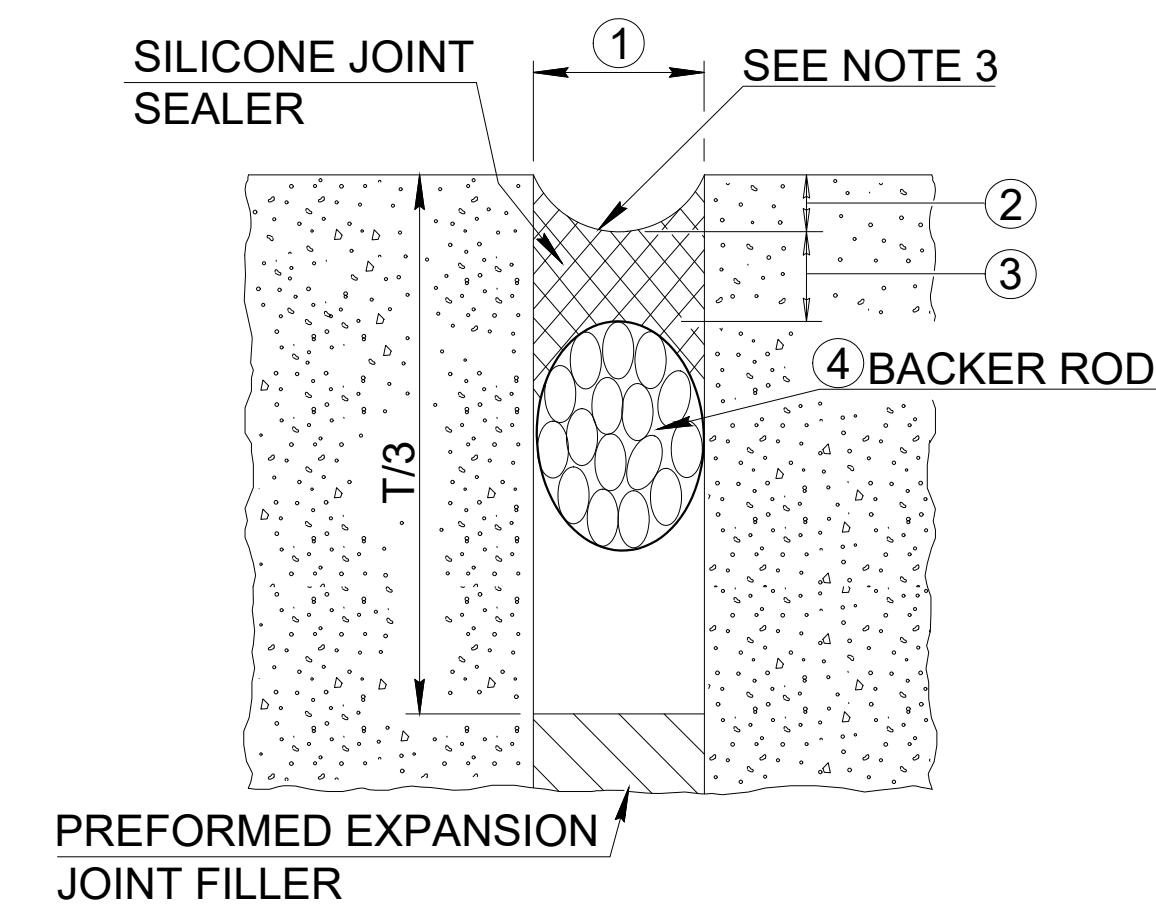

EXPANSION JOINTS / ISOLATION JOINTS

HOT POURED JOINT SEALANT MAY BE USED IN LIEU OF BACKER ROD AND SILICONE SEALANT, IF APPROVED BY THE ENGINEER

EXPANSION JOINT / ISOLATION JOINT TREATMENT TABLE			
JOINT WIDTH	SEALANT RECESS DEPTH	SILICON SEALANT THICKNESS	BACKER ROD DIAMETER
①	②	③	④
1/2"	3/8"	1/4"	5/8"
3/4"	3/8"	3/8"	7/8"
1"	3/8"	1/2"	1 1/4"
1 1/2"	1/2"	3/4"	2"
2"	1/2"	3/4"	2 1/2"

EXPANSION OR ISOLATION JOINT WIDTH SHALL BE 1/2", UNLESS OTHERWISE SPECIFIED ON THE PLANS. TABLE VALUES, AS SHOWN THIS TABLE, SHALL BE USED IN THOSE SPECIFIED CASES.

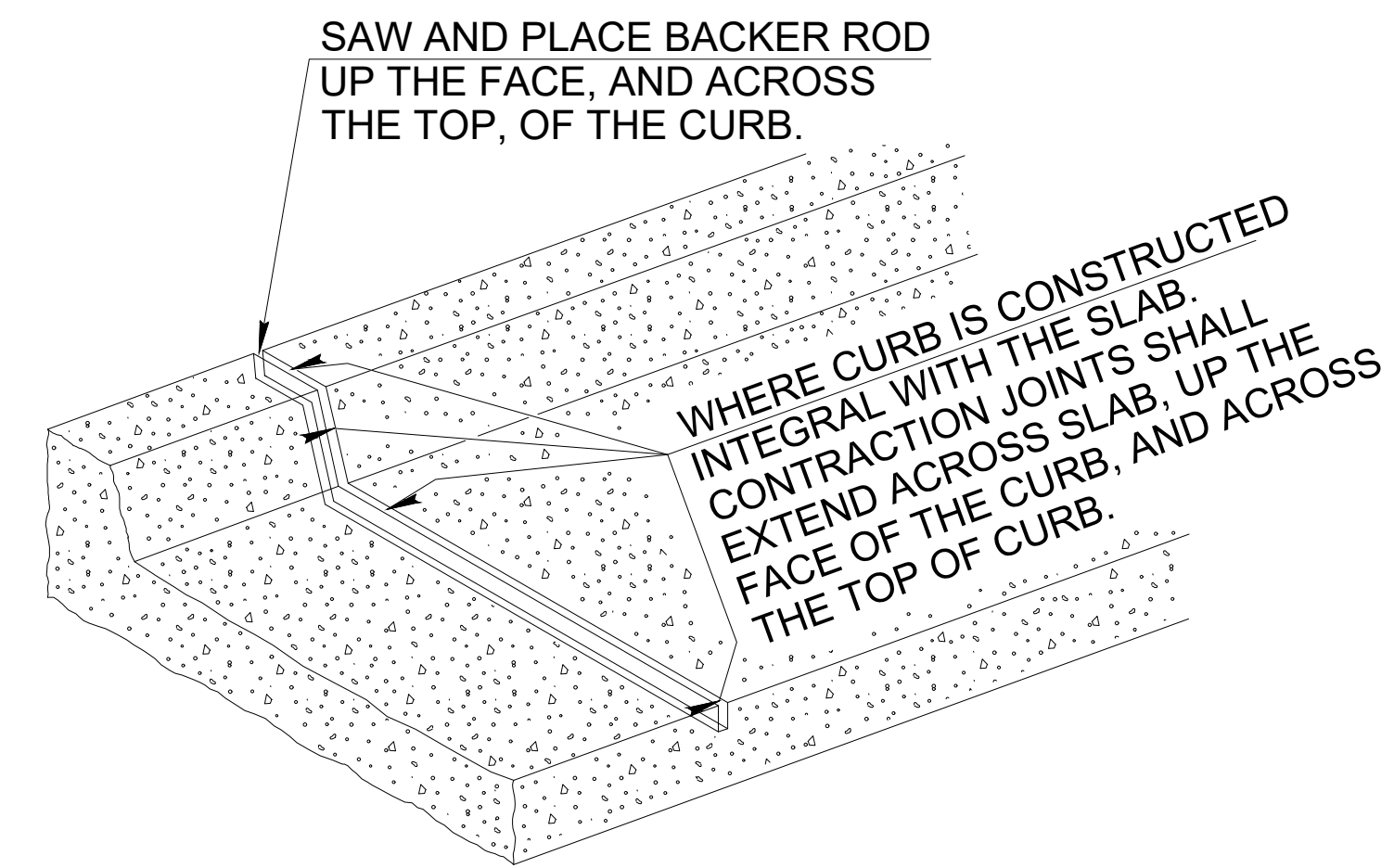

CONTRACTION JOINT WITH INTEGRAL CURB

GENERAL NOTES

- ALL CONSTRUCTION AND MATERIALS REQUIREMENTS SHALL BE IN ACCORDANCE WITH THE OKC STANDARD SPECIFICATIONS.
- ALL CONCRETE JOINT SEALING SHALL BE IN ACCORDANCE WITH SECTION 315 OF THE SPECIFICATIONS.
- THE SHAPE FACTOR, COMBINED WITH THE JOINT CLEANLINESS, IS THE CRITICAL COMBINATION NECESSARY TO GUARANTEE DESIRED BONDING AND FUNCTION OF SEALED JOINTS. THE JOINT SHAPE FACTOR IS DEFINED AS THE FINAL PRESSED SHAPE OF THE SILICONE MATERIAL. THE TOOLING OPERATION WILL FIRMLY PRESS THE FRESHLY APPLIED MATERIAL INTIMATELY AGAINST THE CUT SIDES OF THE RECESS AND THE BACKER ROD SURFACES. THE ROUNDED SHAPE ON TOP AND BOTTOM OF THE SILICONE ALLOWS THE SEALANT TO PROPERLY FLEX BUT MAINTAIN ADHERENCE TO THE PAVING. SELF LEVELING SEALANTS WILL BE INSTALLED TO BE FLUSH WITH THE PAVEMENT SURFACE.
- ON JOINTED PORTLAND CEMENT CONCRETE PAVEMENTS, DOWELLED CONTRACTION JOINTS SHALL BE USED ON DRIVING LANES ONLY. CONCRETE SHOULDERS SHALL NOT BE DOWELLED UNLESS SPECIFIED ON THE PLANS.
- LONGITUDINAL JOINTS BETWEEN PAVEMENT AND TIED CONCRETE SHOULDERS SHALL NOT BE SAWED OR SEALED UNLESS OTHERWISE SHOWN ON THE PLANS.
- ON ALL SAWED JOINTS, THE KERF DEPTH SHALL CLEAR DOWEL BARS, TIE BARS AND/OR REINFORCING STEEL BY A MINIMUM OF 1/2".
- CONTRACTION JOINTS IN JOINTED P.C. PAVEMENT SHALL BE AT APPROXIMATELY 15'-0" CENTERS, UNLESS OTHERWISE SPECIFIED.
- LONGITUDINALLY TINE THE PAVEMENT UNLESS OTHERWISE SPECIFIED, OR AS DIRECTED BY THE ENGINEER. CONSTRUCT LONGITUDINAL GROOVING TO THE FOLLOWING DIMENSIONS: 1/8" TO 3/16" WIDE, 1/8" TO 3/16" DEEP, AND EQUALLY SPACED AT 1/2" TO 1" APART. ENSURE GROOVES ARE NEAT IN APPEARANCE AND OF UNIFORM DEPTH. ALTERNATIVELY, IF TRANSVERSE GROOVING IS APPROVED BY THE CITY ENGINEER, CONSTRUCT TRANSVERSE GROOVING TO THE FOLLOWING DIMENSIONS: 1/8" TO 3/16" WIDE, 1/8" TO 3/16" DEEP, AND EQUALLY SPACED AT 1/2" TO 1" APART.
- CONCRETE PAVEMENTS (SUCH AS DETOURS AND CROSSOVERS) THAT ARE INTENDED TO BE REMOVED BY THE END OF THE PROJECT SHALL NOT BE SEALED.

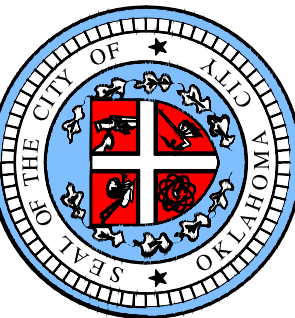

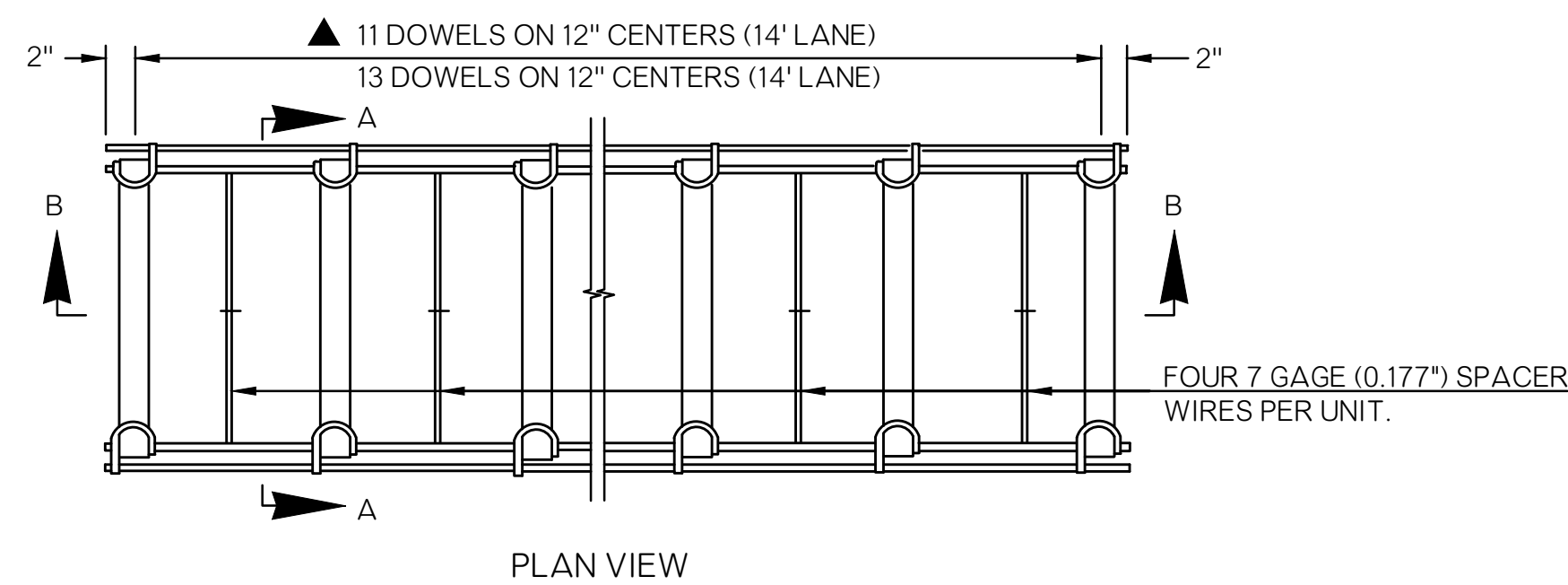

PLAN VIEW

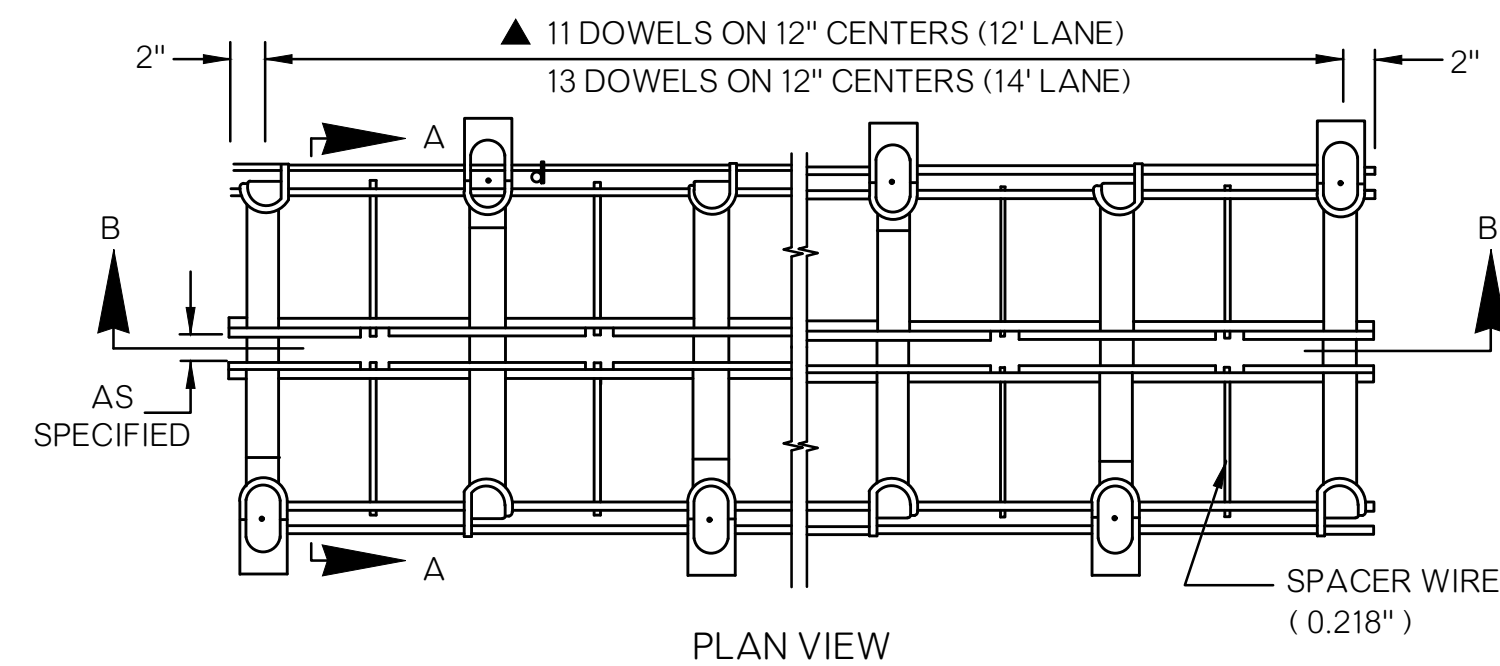

PLAN VIEW

DOWEL BARS			
▲ SPACING & SIZE DATA			
(T) SLAB DEPTH	(D) DOWEL DIA.	TOTAL DOWEL LENGTH	C/C DOWEL SPACING
7"-10"	1 1/2"	18"	12"
10 1/2"& UP	1 1/2"	18"	12"

DOWEL DIAMETER WILL BE DETERMINED BY THE SLAB DEPTH (T) OR THE NOMINAL DEPTH WHEN SLAB DEPTH VARIES. WHEN NOMINAL DEPTH VALUE IS TO BE USED, THE CALCULATED NOMINAL DEPTH WILL BE SHOWN ON THE PLANS.

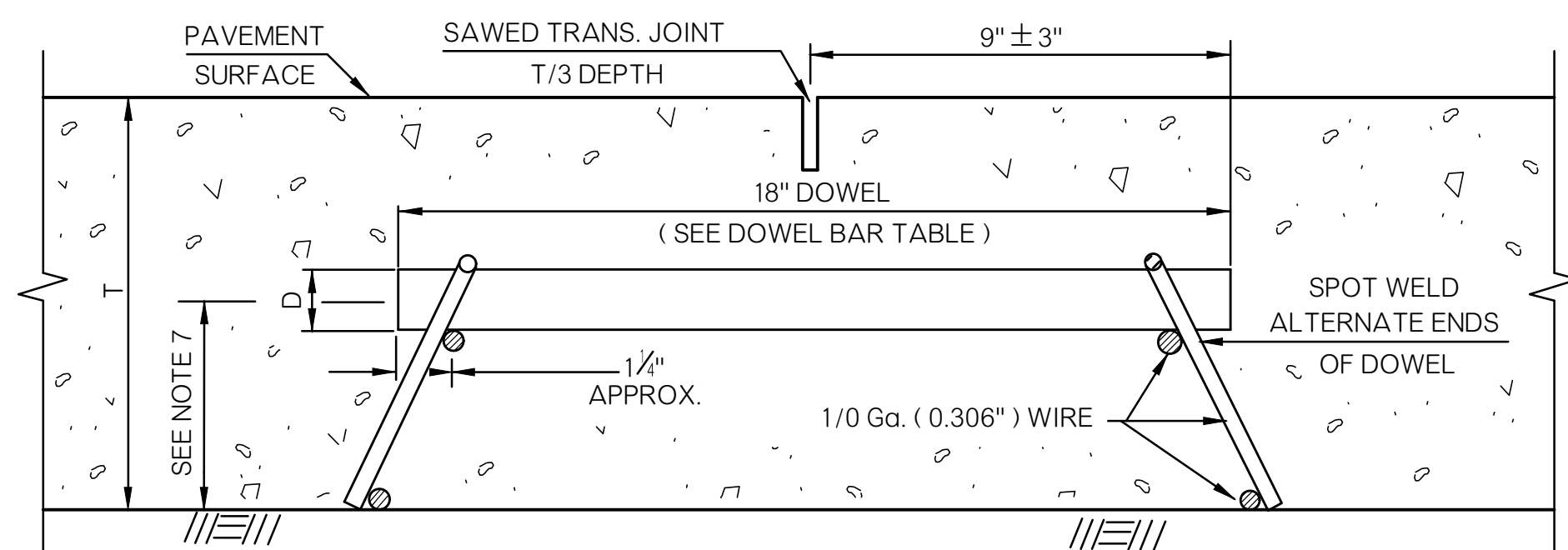

SECTION A-A

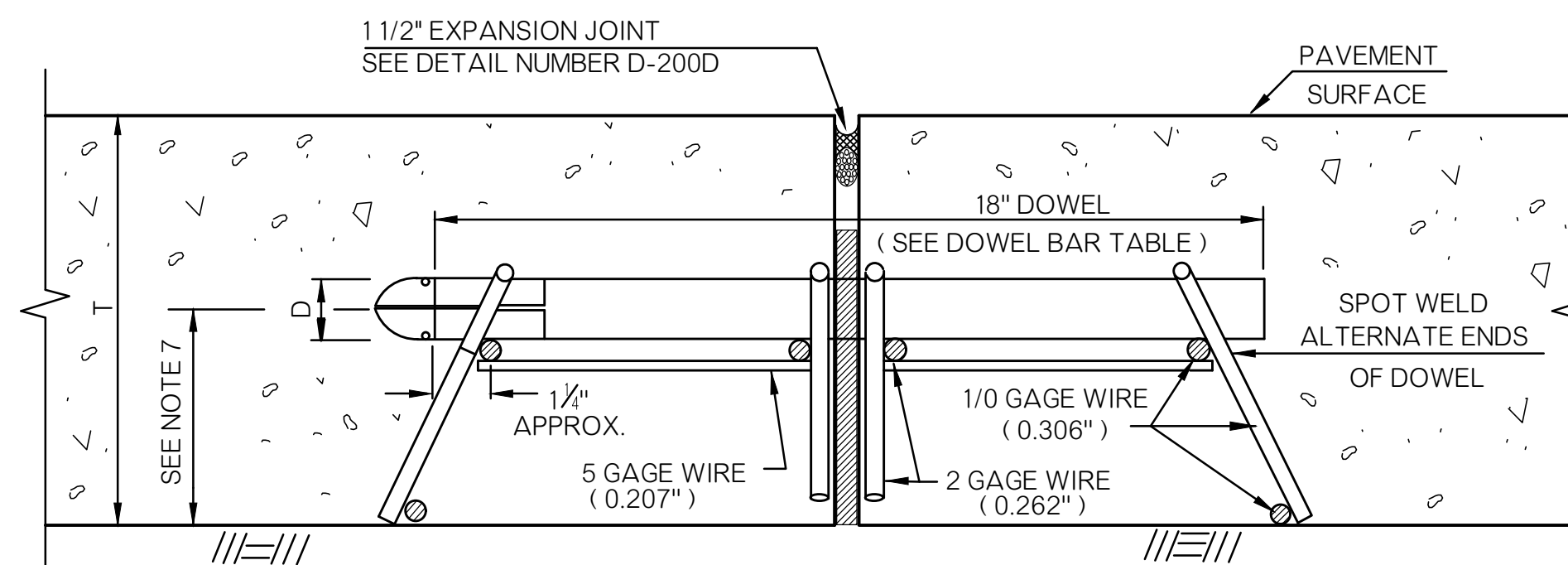

SECTION A-A

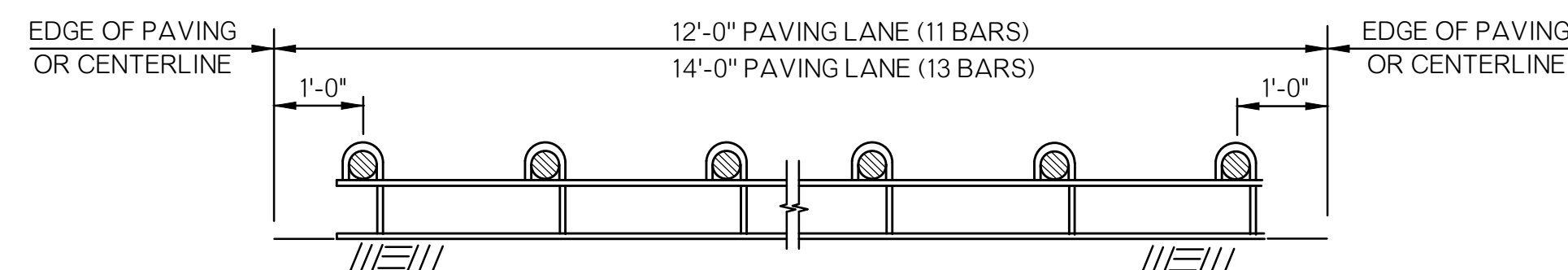

SECTION B-B

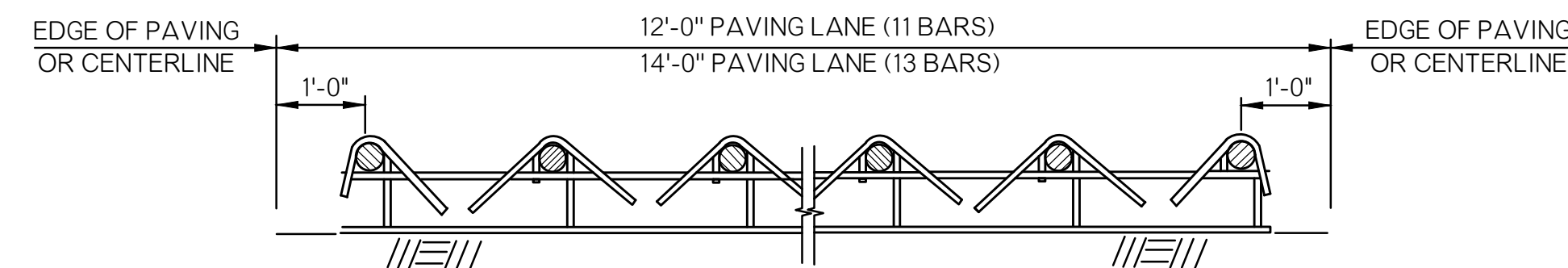

SECTION B-B

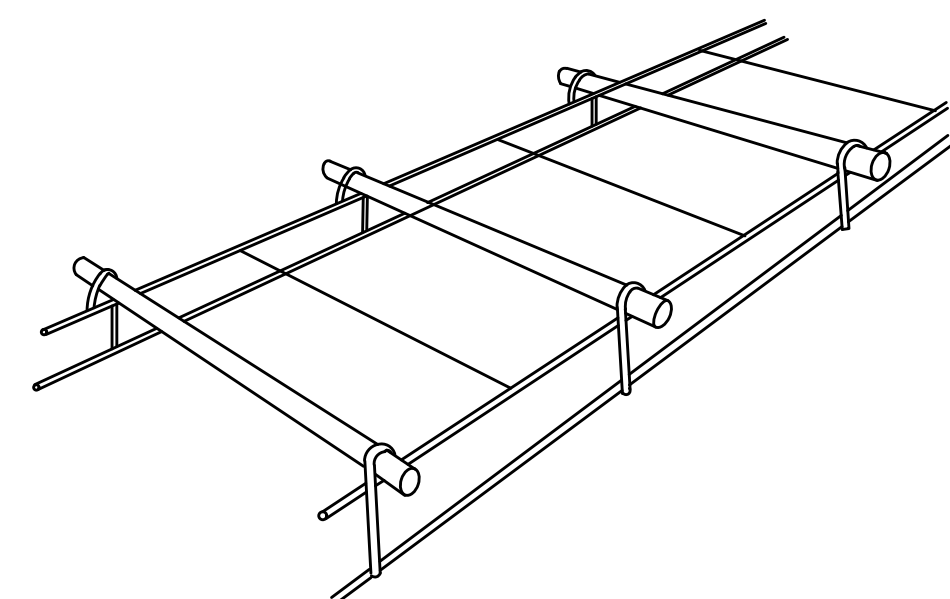

WELDED CONTRACTION JOINT ASSEMBLY

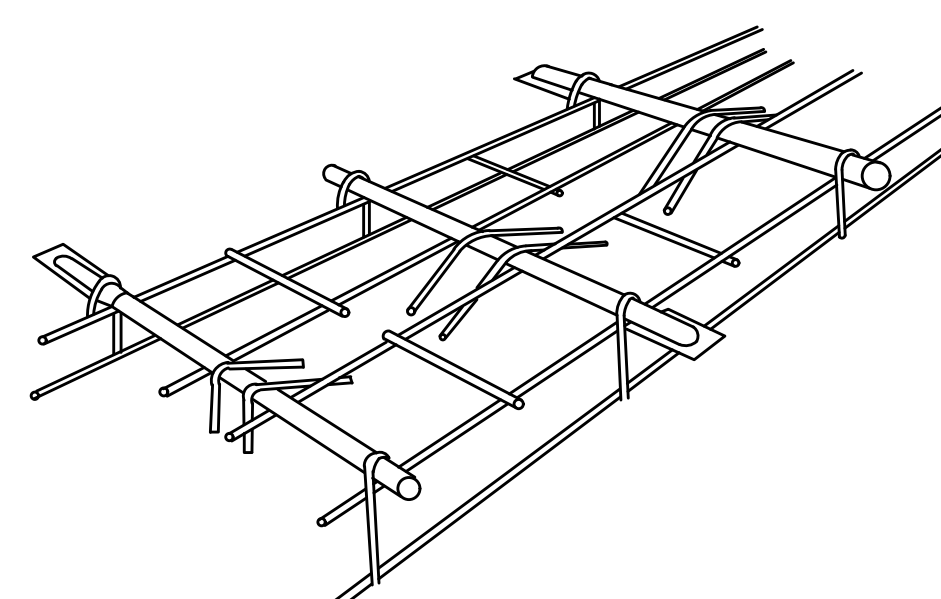

WELDED EXPANSION JOINT ASSEMBLY

GENERAL NOTES

- ALL CONSTRUCTION AND MATERIAL REQUIREMENTS SHALL BE IN ACCORDANCE WITH THE OKC STANDARD SPECIFICATIONS FOR CONSTRUCTION OF PUBLIC IMPROVEMENTS.
- ANY DEVICE USED FOR SUPPORTING DOWELS SHALL HAVE SUFFICIENT RIGIDITY AND BE HELD IN PLACE DURING CONCRETE PLACEMENT SO THAT DOWELS WILL BE IN SPECIFIED POSITION IN THE FINISHED PAVEMENT. ANY DEVICE NOT PRODUCING THE SPECIFIED RESULTS SHALL BE REJECTED.
- PRODUCER AND CONTRACTOR SHALL AVOID PATENT INFRINGEMENT OF THE BASKET AND SHALL SAVE THE CITY HARMLESS IN THE USE OF ANY BASKET.
- THE CONTRACTOR MAY SELECT THE TYPE OF BASKET TO BE USED. AFTER THE SELECTION IS MADE, THE SAME TYPE BASKET SHALL BE USED THROUGHOUT THE PROJECT, UNLESS APPROVED OTHERWISE BY THE CITY ENGINEER.
- COLD-DRAWN STEEL WIRE, USED FOR DOWEL BASKETS, SHALL BE ACCEPTED BY VISUAL FIELD INSPECTION, AS PROVIDING SUFFICIENT DOWEL BAR SUPPORT DURING PAVING PROCESS.
- ▲ DOWEL BARS SHALL BE GRADE 60 PLAIN BARS. DOWEL BARS SHALL BE CENTERED ON THE BASKET REGARDLESS OF THE WIDTH OF THE BASKET OR THE LENGTH OF THE DOWEL BAR.
- THE HEIGHT OF THE LOAD TRANSFER UNIT (MEASURED TO THE CENTER OF THE DOWEL BAR FROM THE PAVEMENT SURFACE) SHALL BE 1/2 THE THICKNESS OF THE PAVEMENT, PLUS OR MINUS 1/2 THE DIAMETER OF DOWEL BAR OF THE UNIT.
- DOWEL BARS SHALL HAVE A SHOP APPLIED EPOXY COATING OVER THEIR ENTIRE LENGTH (ENDS EXCEPTED). ADDITIONALLY, DOWELS SHALL BE COMPLETELY COATED WITH A FORM RELEASE AGENT (OR APPROVED EQUIVALENT BOND BREAKER) APPLIED IN THE FIELD, IMMEDIATELY PRIOR TO PAVING. THE FORM RELEASE AGENT SHALL NOT BE ALLOWED TO EVAPORATE FROM THE BARS PRIOR TO PAVING.
- FOR EXPANSION JOINTS, THE DOWEL BARS SHALL HAVE EXPANSION CAPS WITH A MINIMUM 1" AND A MAXIMUM 2" AIR SPACE IN THE END OF THE EXPANSION CAPS (EXPANSION JOINT ASSEMBLIES).
- THE CONTRACTOR SHALL DEMONSTRATE TO THE CITY ENGINEER A STAKING PATTERN THAT SHALL SECURE ALL DOWEL BASKETS SUCH THAT THE FINAL DOWEL POSITION IS WITHIN SPECIFICATION LIMITS.
- FOR EXPANSION JOINTS, IN ADDITION TO THE SUPPORTS INDICATED, THE CONTRACTOR SHALL PROVIDE SUITABLE INSTALLING DEVICES AND SUCH ADDITIONAL STAKES AS MAY BE REQUIRED TO HOLD THE JOINT FILLER VERTICAL AND SECURELY IN LINE AND POSITION. THE CONTRACTOR WILL ALSO BE REQUIRED TO SATISFACTORILY FORM THE UPPER PORTION OF THE JOINT FOR RECEIVING THE SEAL. SEE ATTACHED DETAIL NUMBER D-200D.

The City of
Oklahoma City
Public Works Department
Engineering Division

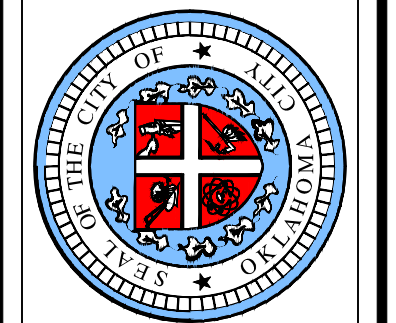

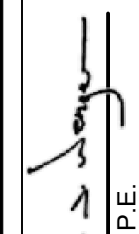
APPROVED BY:  DATE: 09/12/2023
ERIC J. WENGER, P.E.
CITY ENGINEER
DRAWN: OKC-PW-SRB
DATE: 3/9/2023

**LOAD TRANSFER UNITS FOR
CONCRETE PAVEMENT JOINTS
DETAILS**

Detail Number
D-200E

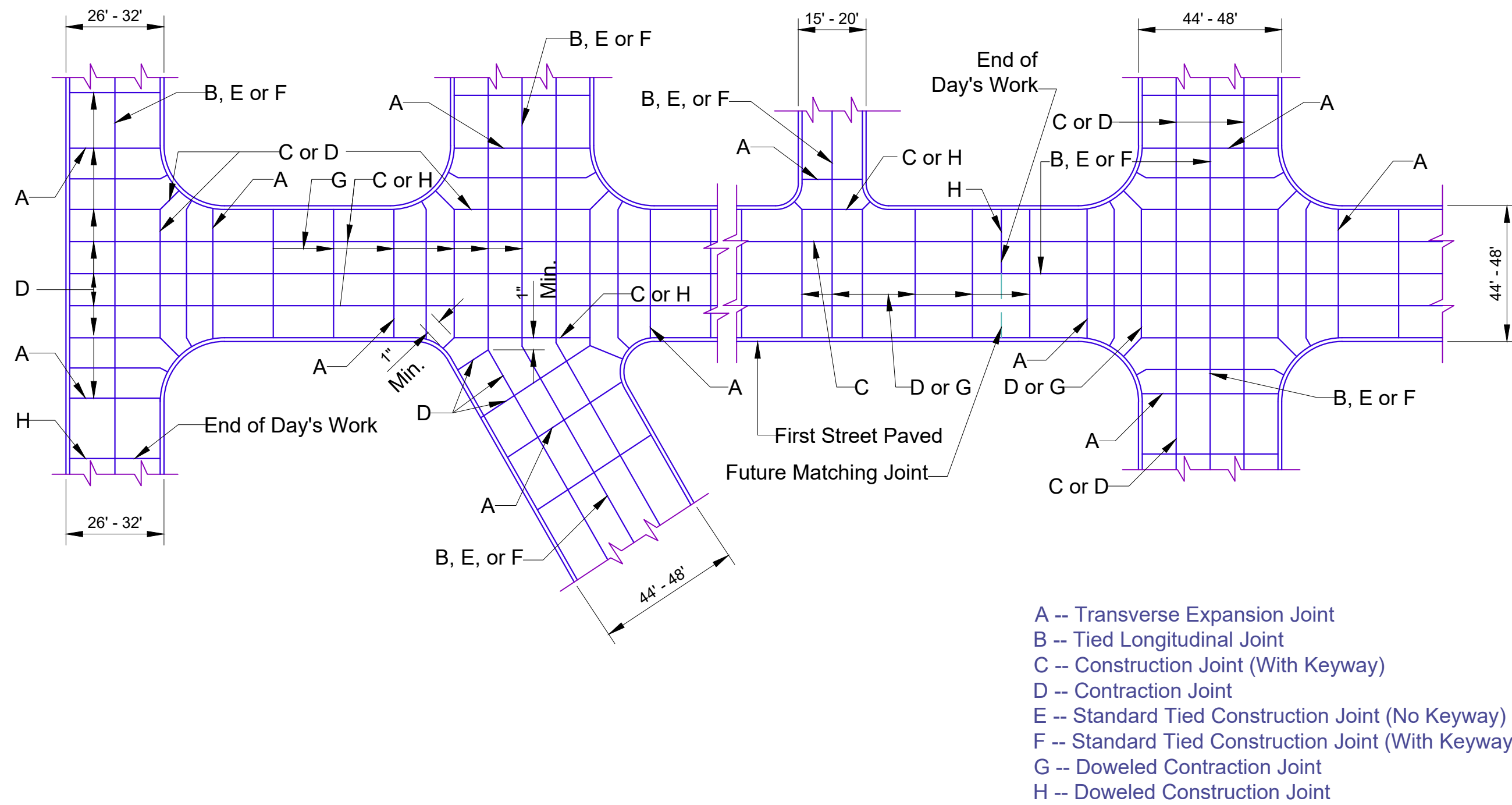

JOINT LAYOUT DETAILS

- A -- Transverse Expansion Joint
- B -- Tied Longitudinal Joint
- C -- Construction Joint (With Keyway)
- D -- Contraction Joint
- E -- Standard Tied Construction Joint (No Keyway)
- F -- Standard Tied Construction Joint (With Keyway)
- G -- Doweled Contraction Joint
- H -- Doweled Construction Joint

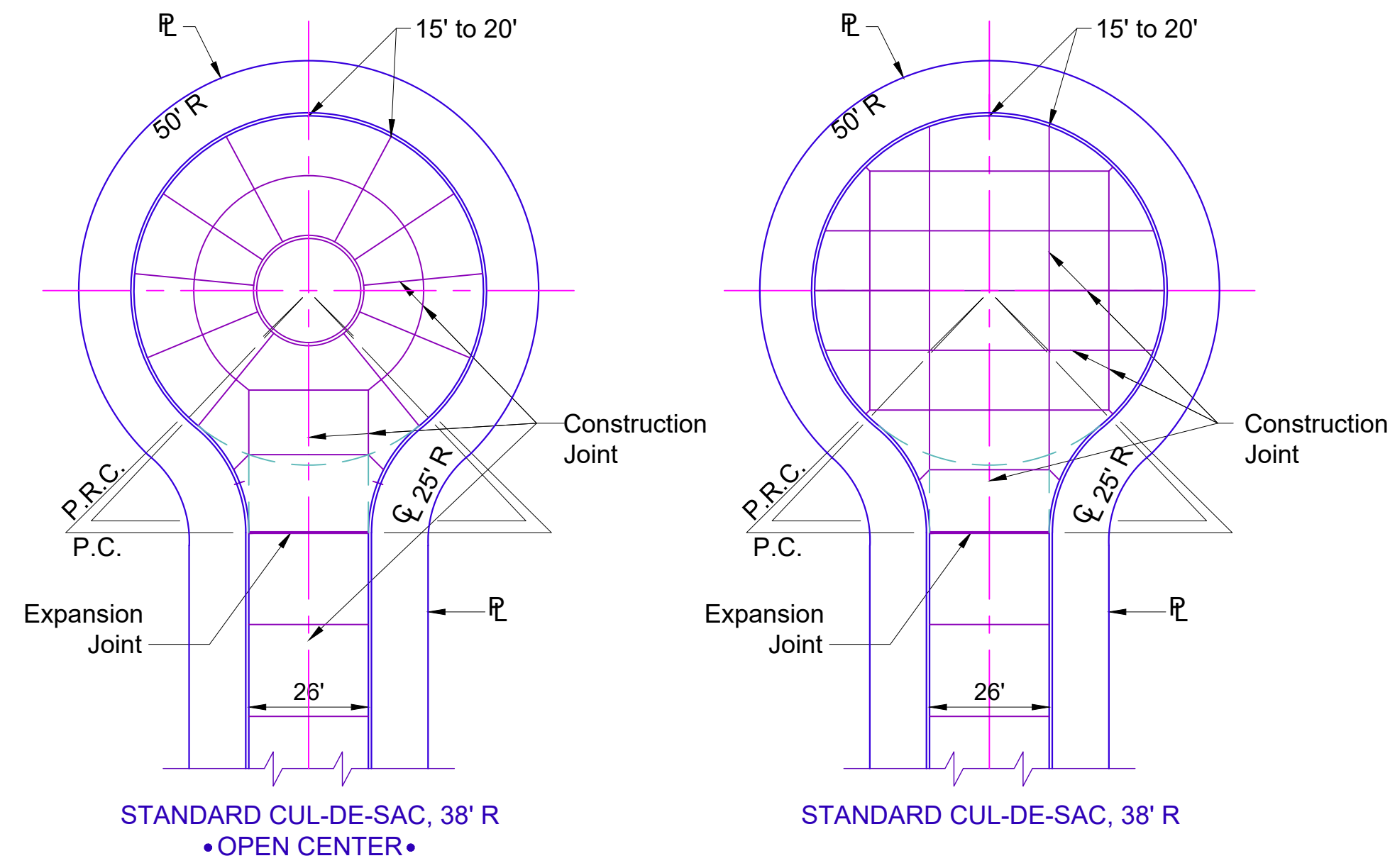

JOINT LAYOUT DETAILS

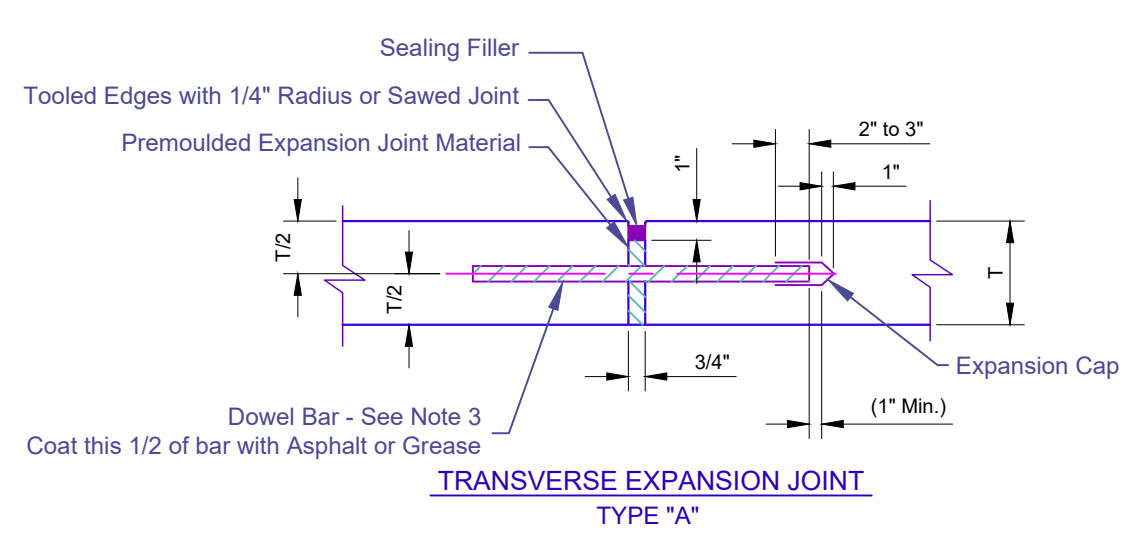

TRANSVERSE EXPANSION JOINT TYPE "A"

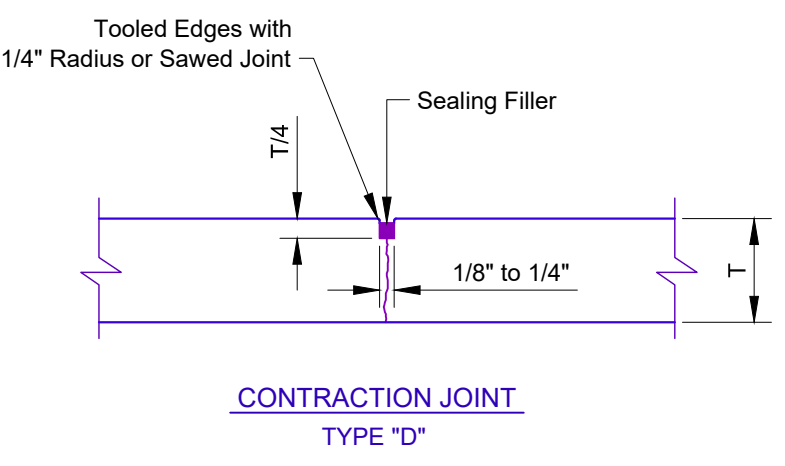

CONTRACTION JOINT TYPE "D"

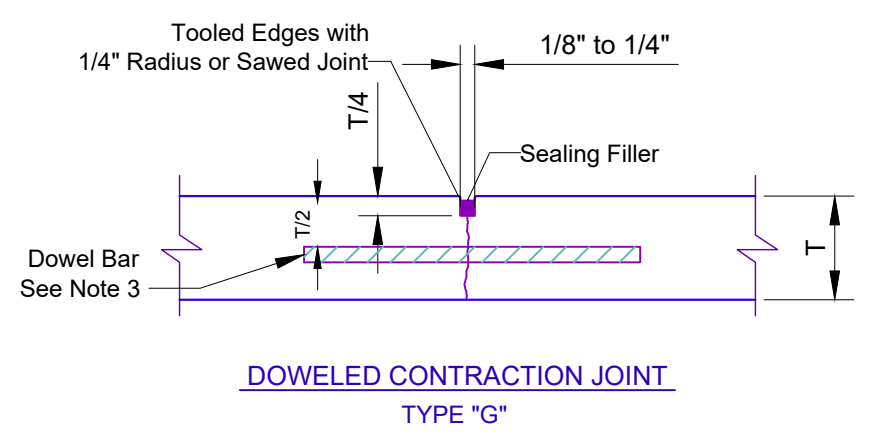

DOWELED CONTRACTION JOINT TYPE "G"

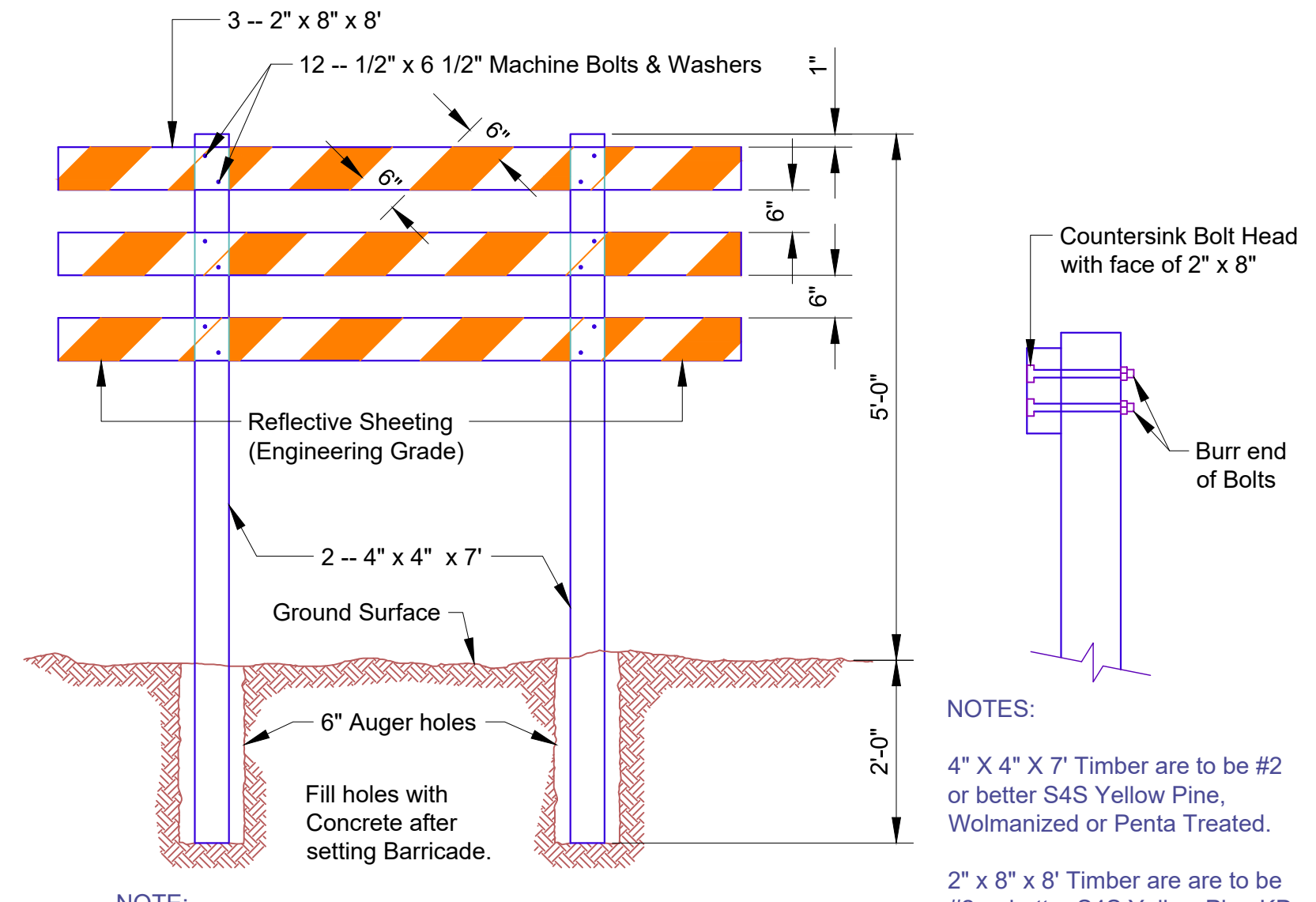

NOTE:

Markings for Barricade Rails are to be Orange and White. Markings are to be 6" wide and attached at 45° angles as set forth in the latest edition of the Uniform Traffic Control Devices Manual

STANDARD REFLECTOR TYPE BARRICADE

- NOTES:
- 4" X 4" X 7" Timber are to be #2 or better S4S Yellow Pine, Wolmanized or Penta Treated.
 - 2" x 8" x 8" Timber are to be #2 or better S4S Yellow Pine KD.

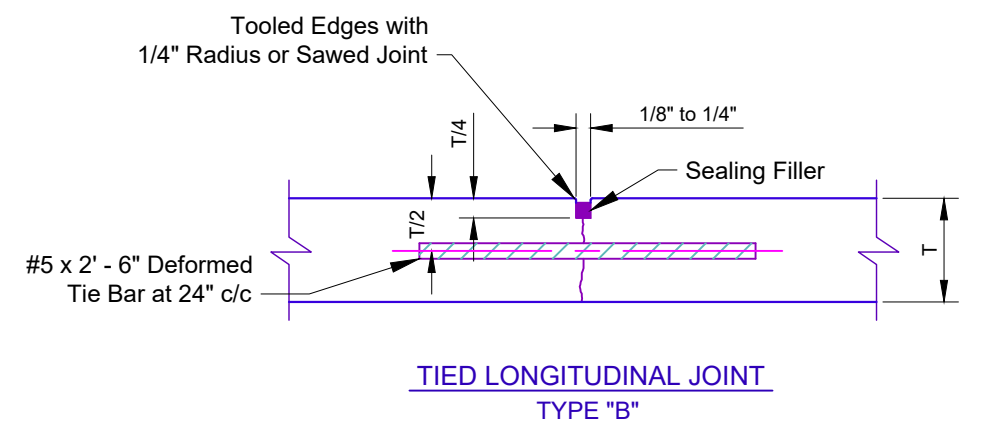

TIED LONGITUDINAL JOINT TYPE "B"

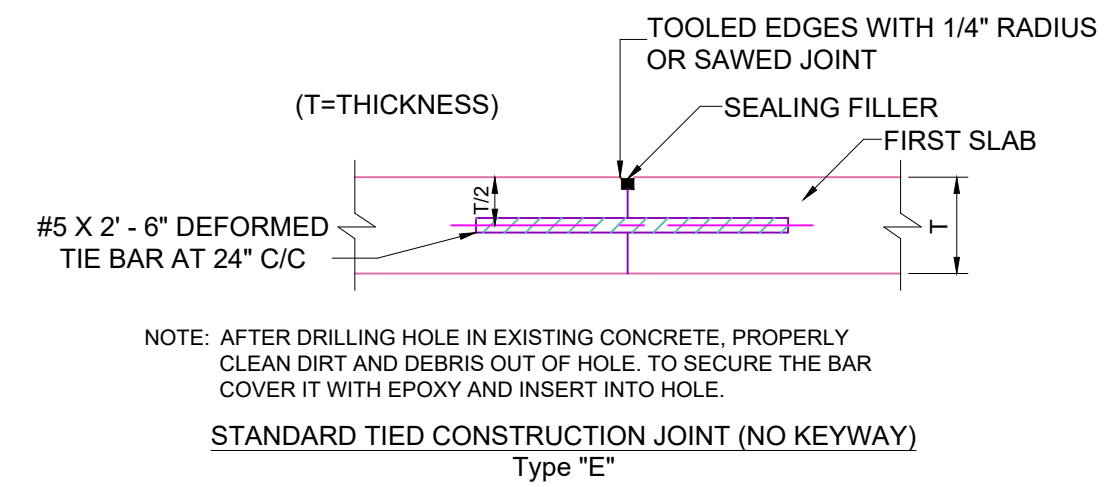

STANDARD TIED CONSTRUCTION JOINT (NO KEYWAY) Type "E"

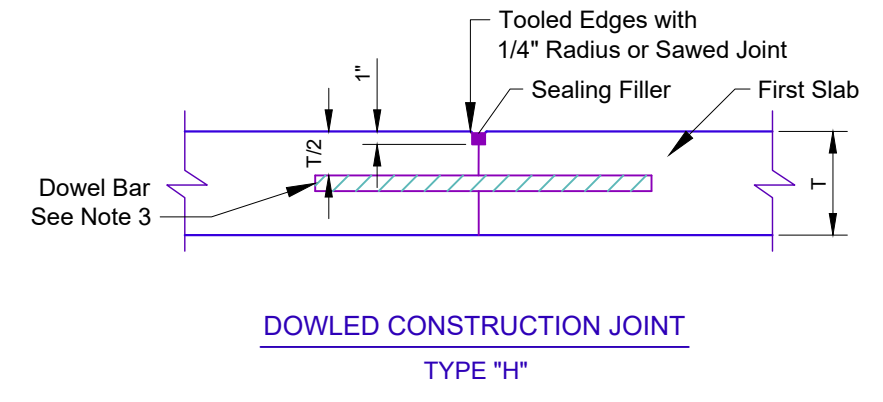

DOWELED CONSTRUCTION JOINT TYPE "H"

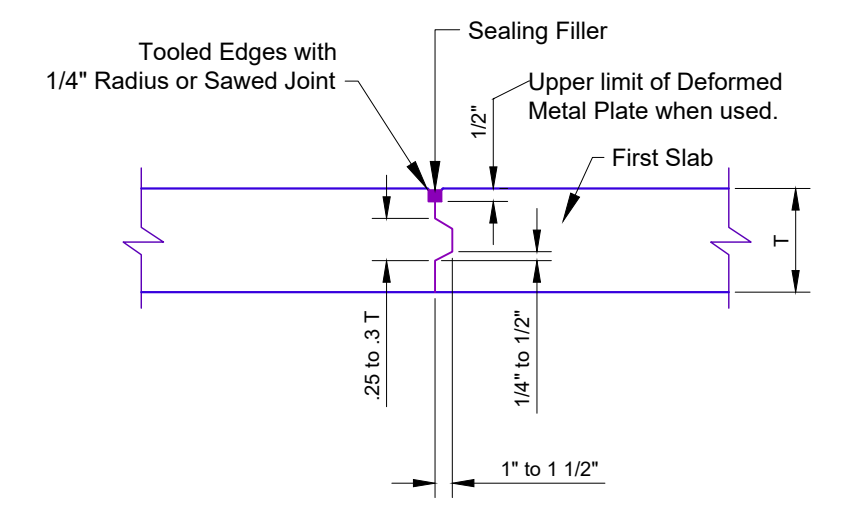

CONSTRUCTION JOINT (WITH KEYWAY) TYPE "C"

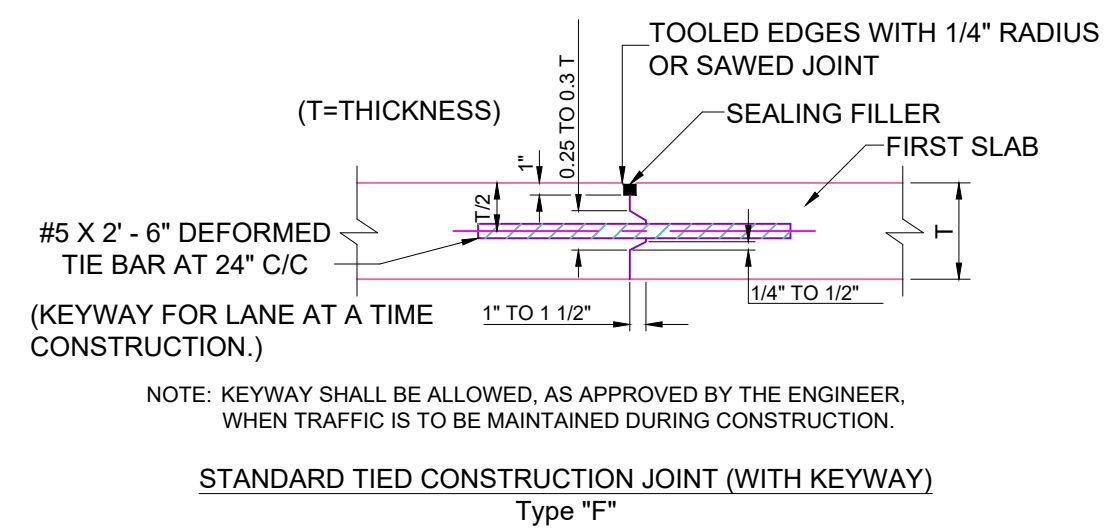

STANDARD TIED CONSTRUCTION JOINT (WITH KEYWAY) Type "F"

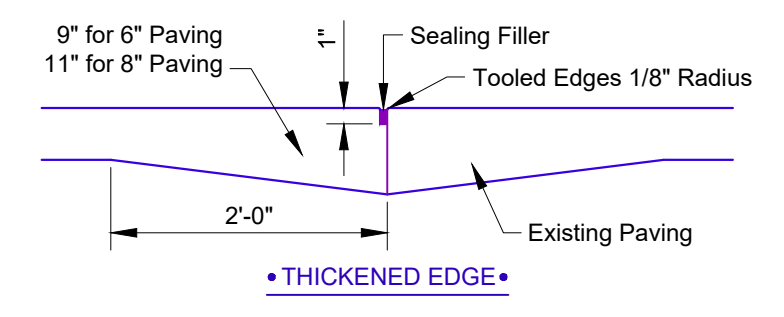

THICKENED EDGE

MISCELLANEOUS DETAILS

- NOTES:
1. Smooth Dowel Bars across Expansion Joints shall be provided with Expansion Caps, and coated with Asphalt or Grease, (Type A & H).
 2. Grooves in Joints may be formed by: (1) temporary embedment of a suitable Mandrel, (2) installation of a thin strip of premoulded Joint Filler Material, (3) sawing the Pavement after the Concrete has hardened.
 3. See Dowel Bars Table on Drawing D-200 E to size dowels.

C:\Users\conor.holland\OneDrive - City of Oklahoma City\Projects\Active\Standard Details\C3D\Drawings\D-200_DRAFT.dwg, 6/9/2026 8:07:26 AM

APPROVED BY: *Debbie Miller*
CITY ENGINEER
DATE: 6/15/26
DRAWN: CH
DATE: 06-09-26

**STANDARD TYPICAL SECTIONS
MISCELLANEOUS DETAILS**

C:\Users\comor.holland\OneDrive - City of Oklahoma City\Projects\Active\Standard Details\C3D\Drawings\D-300_DRAFT.dwg, 6/9/2026 8:07:23 AM

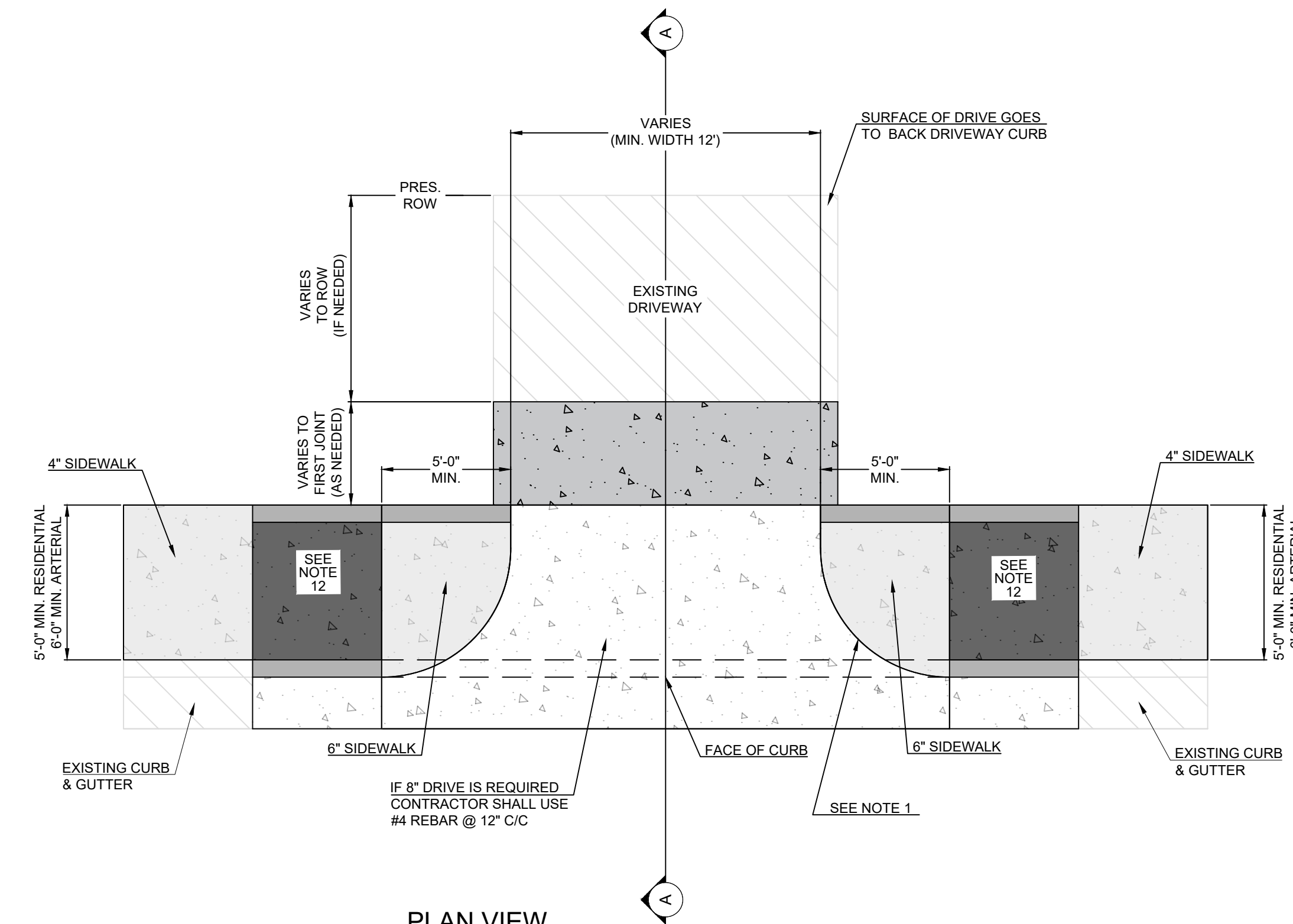
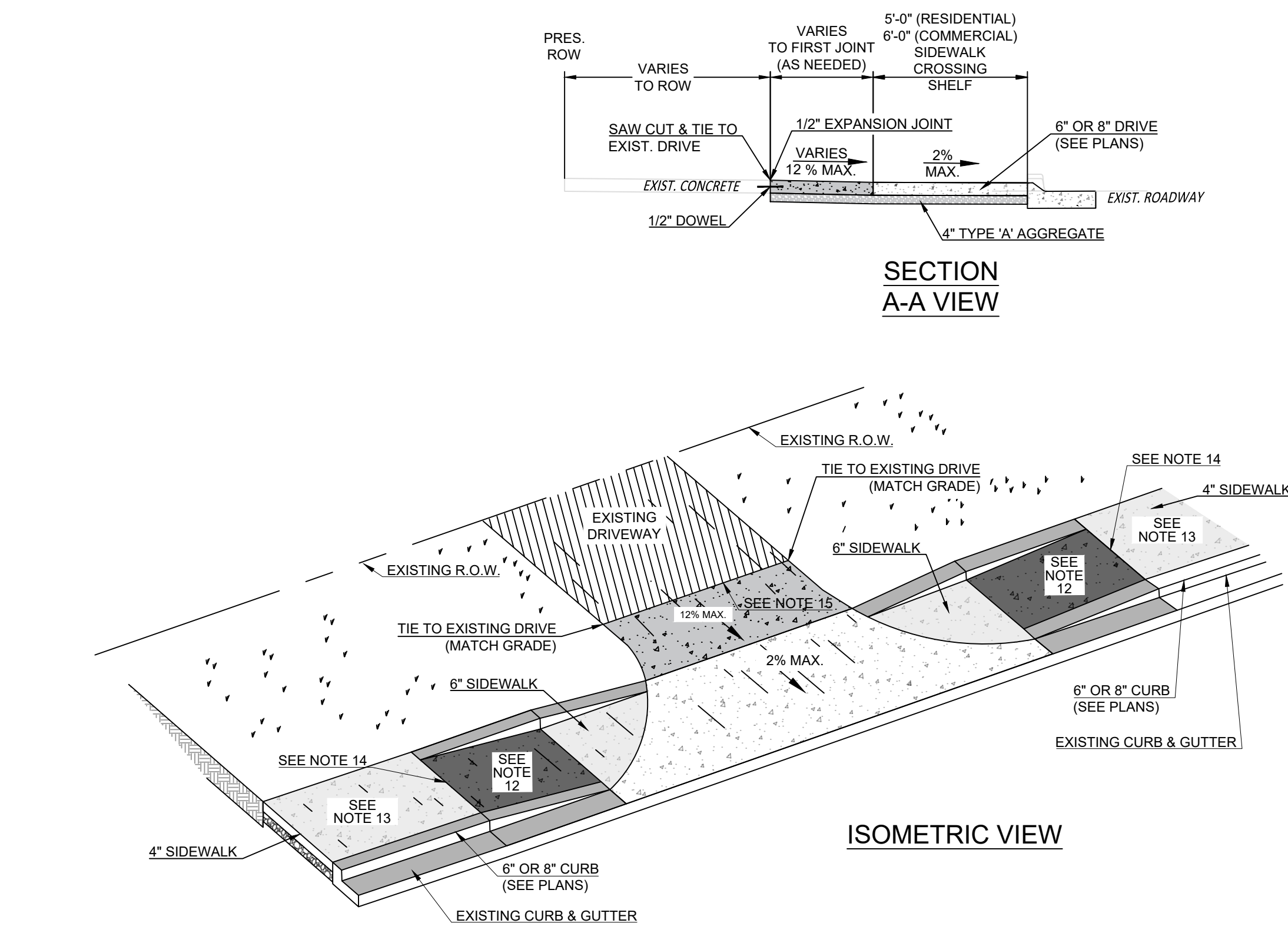

TYPICAL DRIVEWAY
DETAIL OF SIDEWALK ADJACENT TO CURB AT DRIVEWAY
N.T.S.

DRIVEWAY /SIDEWALK NOTES

1. SEE DRIVEWAY MINIMUM STANDARDS ON D-300 B FOR RADIUS DIMENSION.
 2. THE DRIVEWAY CONTRACTOR SHALL SAW CUT & REMOVE THE COMPLETE CURB AND GUTTER SECTION. SAW CUTS SHALL BE 2" OR 1/3 THE DEPTH OF THE GUTTER, WHICHEVER IS GREATER, INCLUDE THE TOP & FACE OF CURB AS WELL AS THE GUTTER, BE MADE PRIOR TO THE REMOVAL OF CONCRETE, AND BE FULL DEPTH FOR REMOVAL.
 3. IF A GUTTER HOLDS WATER PRIOR TO ANY CONSTRUCTION BY DRIVEWAY CONTRACTOR, HE SHOULD NOTIFY THE CITY ENGINEER OF THE SITUATION BEFORE DOING ANY WORK. THE COMPLETED DRIVEWAY WORK WILL NOT BE ACCEPTED IF THE GUTTER HOLDS WATER DUE TO POOR CONSTRUCTION BY THE CONTRACTOR.
 4. IT IS RECOGNIZED THAT THIS DRIVEWAY DETAIL DOES NOT COVER EVERY POSSIBLE SITUATION ENCOUNTERED IN CONSTRUCTION. HOWEVER, OTHER OPTIONS SUCH AS MOUNTABLE CURB AND GUTTER, ONE FOOT WIDE BY 2 INCH HIGH LIP AT THE GUTTER, NARROWING THE WIDTH OF THE PEDESTRIAN PATHWAY TO 36 INCHES, ETC. WILL BE CONSIDERED TO HELP MEET ADA REQUIREMENTS.
 5. CLEAN AND SEAL ALL JOINTS AND SAW CUTS IN ACCORDANCE WITH STANDARD SPECIFICATIONS.
 6. LONGITUDINAL AND TRANSVERSE JOINTS, REQUIRED FOR DRIVES 12' WIDE & OVER. SAW CUT 2" OR 1/3 DEPTH AND FILL WITH SILICONE SEALANT.
 7. DO NOT TURN RADIUS IN FRONT OF ADJACENT PROPERTY WITHOUT WRITTEN PERMISSION FROM ADJACENT PROPERTY OWNER.
 8. COMMERCIAL AND INDUSTRIAL DRIVEWAY APPROACHES MAY BE THICKER OR AS APPROVED BY THE CITY ENGINEER.
 9. WHEN CONNECTING A NEW SIDEWALK TO AN EXISTING STEEP DRIVEWAY, WHICH CANNOT BE MADE ADA COMPLIANT, THE TRANSITION PANEL ON EACH SIDE OF THE DRIVEWAY SHALL NOT BE MORE THAN 5' IN LENGTH, UNLESS APPROVED BY THE ENGINEER.
 10. FOR A RESIDENTIAL OR COMMERCIAL STRUCTURE LOCATED BELOW STREET LEVEL, THE HIGH POINT OF THE SIDEWALK WHERE IT CROSSES THE DRIVEWAY SHALL BE AT LEAST 6" ABOVE THE STREET GUTTER ELEVATION.
 11. DRAINAGE STRUCTURES SHALL NOT BE PLACED IN LINE WITH THE RAMPS.
 12. IF SLOPE OF RAMP EXCEEDS 5.0% A LEVEL LANDING WILL BE REQUIRED AT TOP OF RAMP.
 13. ALL CROSS SLOPES AND RUNNING SLOPES FOR LANDINGS AND CROSS SLOPES FOR SIDEWALKS SHALL BE 1.5% PREFERRED TO 2% MAX.
 14. EXPANSION JOINT WITH 3 - 1/2" SMOOTH DOWELS, 18" LONG, GREASED ON ONE END IN 4' SIDEWALK AND 4 - 1/2" SMOOTH DOWELS, 18" LONG GREASED ON ONE END IN 5' SIDEWALK (TYPICAL).
 15. EXPANSION JOINT WITH 1/2" SMOOTH DOWELS, 18" LONG @ 18" C/C GREASED ON ONE END (TYPICAL).
- * ALL SAWCUTS SHALL BE SEALED

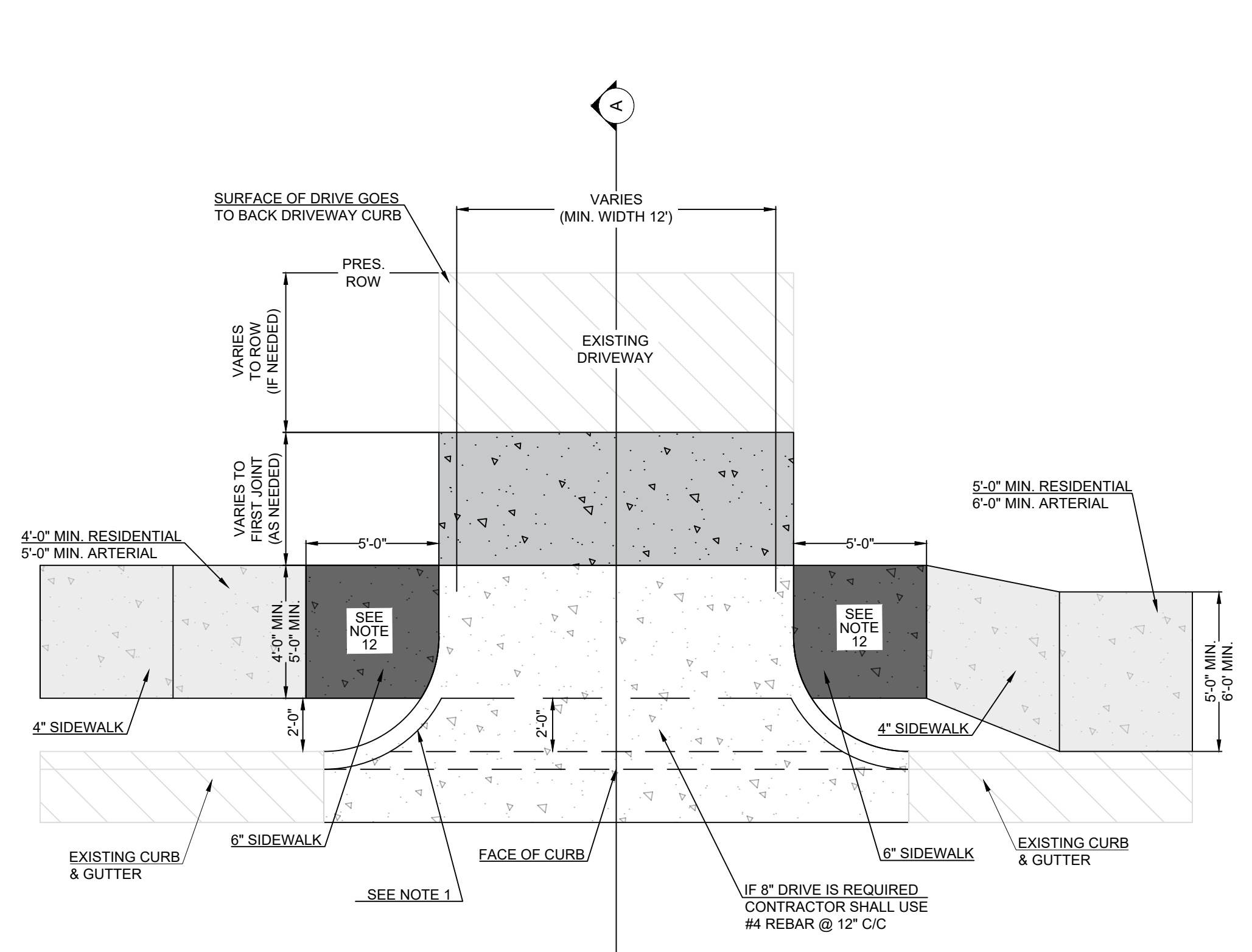
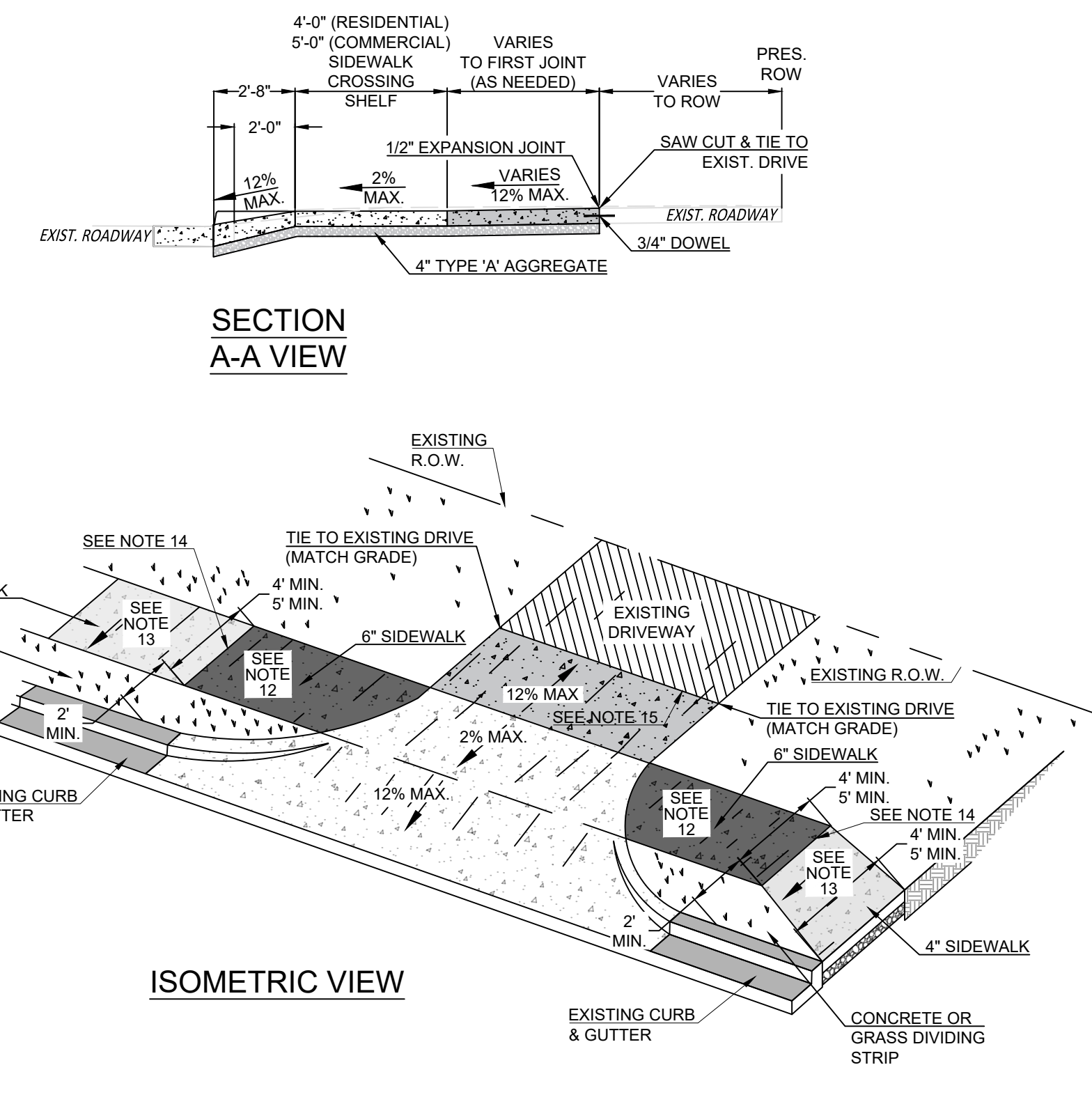
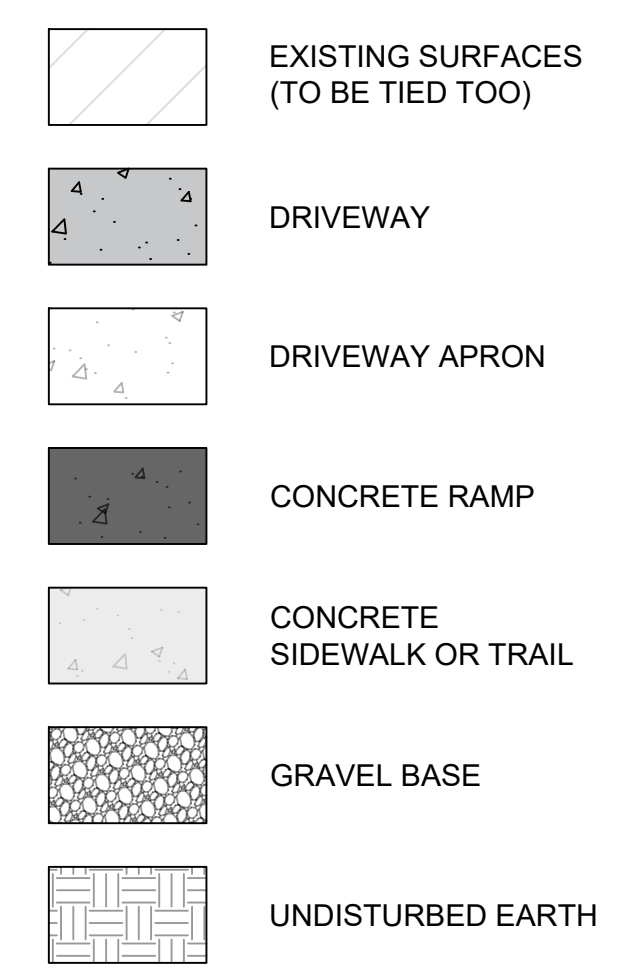

TYPICAL DRIVEWAY
DETAIL OF SIDEWALK NOT ADJACENT TO CURB AT DRIVEWAY
N.T.S.

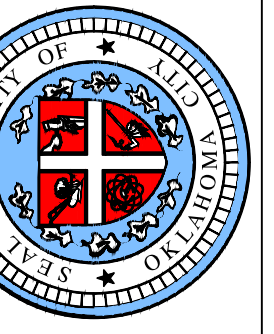

**STANDARD TYPICAL SECTION
 DRIVEWAY DETAILS**

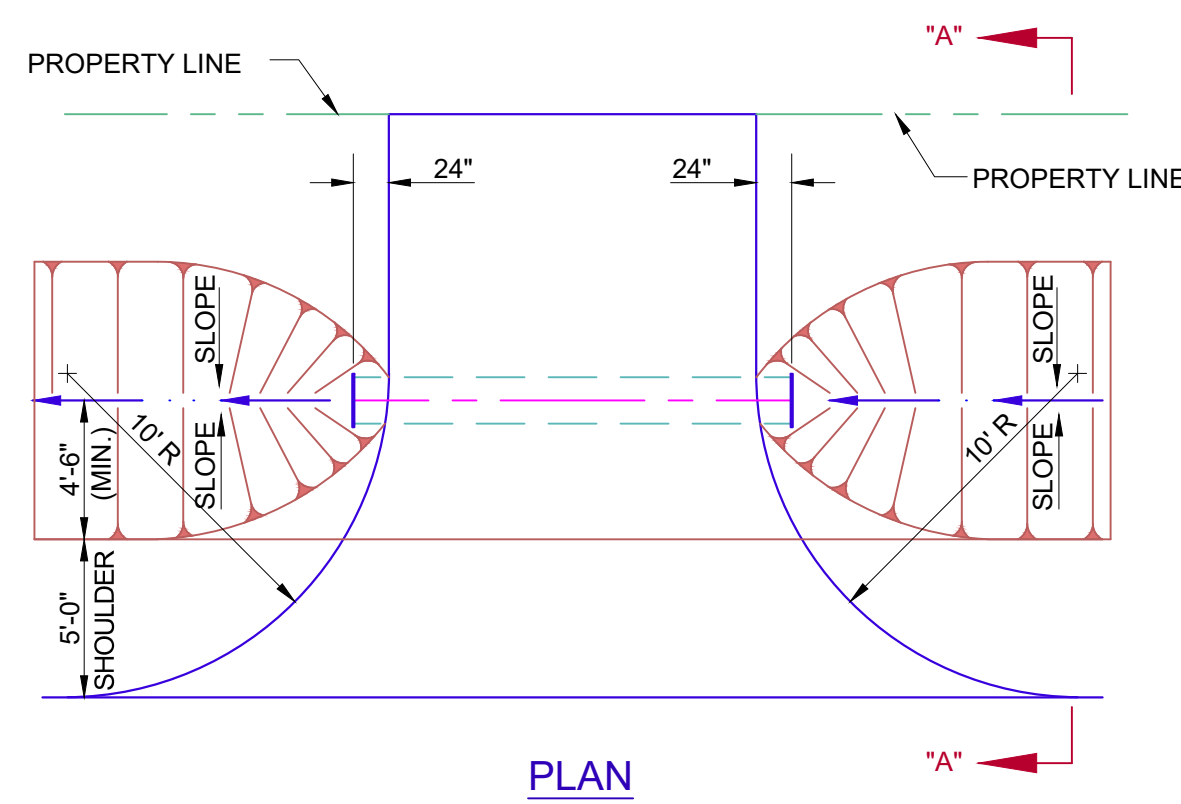

PLAN

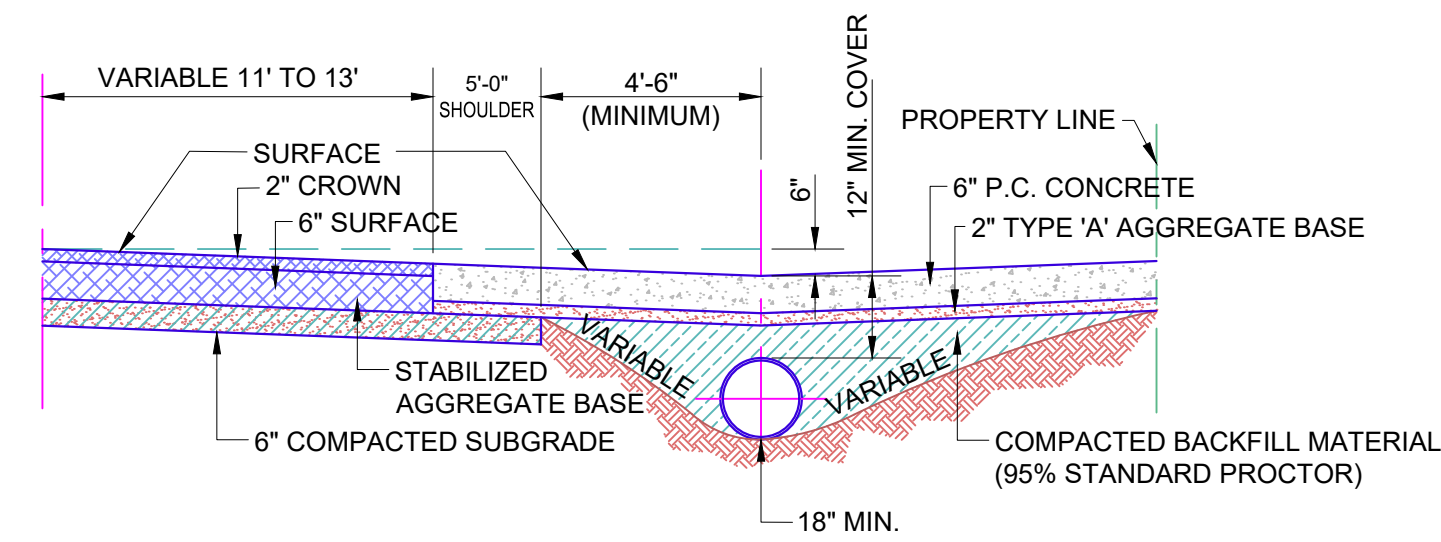

SECTION "A - A"

DRIVEWAY DETAILS FOR RURAL ESTATES DEVELOPMENT

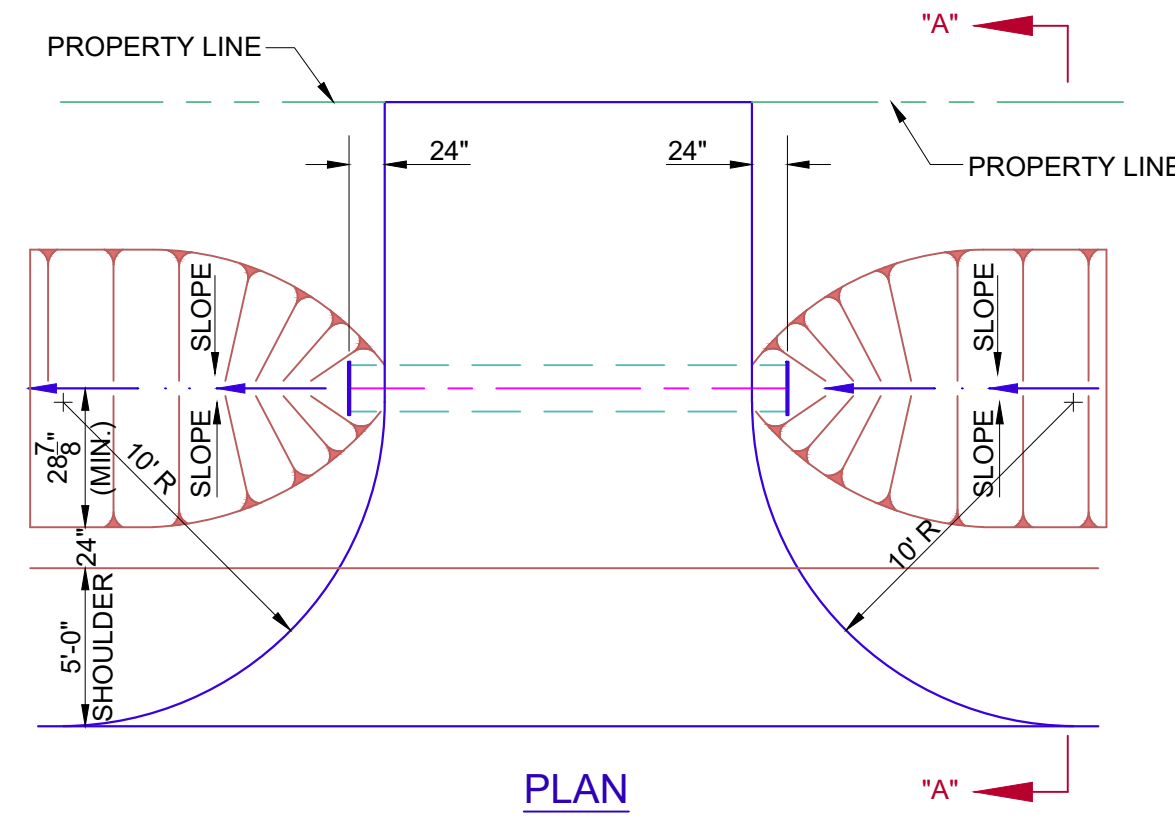

PLAN

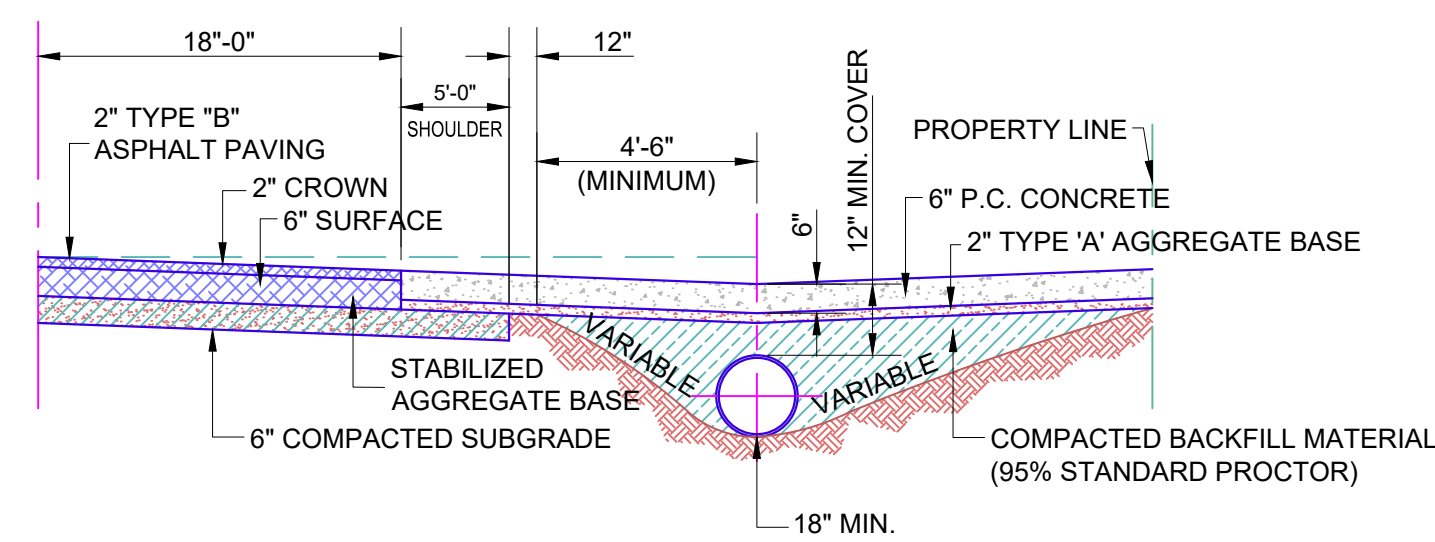

SECTION "A - A"

DRIVEWAY DETAILS FOR AGRICULTURAL ESTATES
 R-1 ZONING

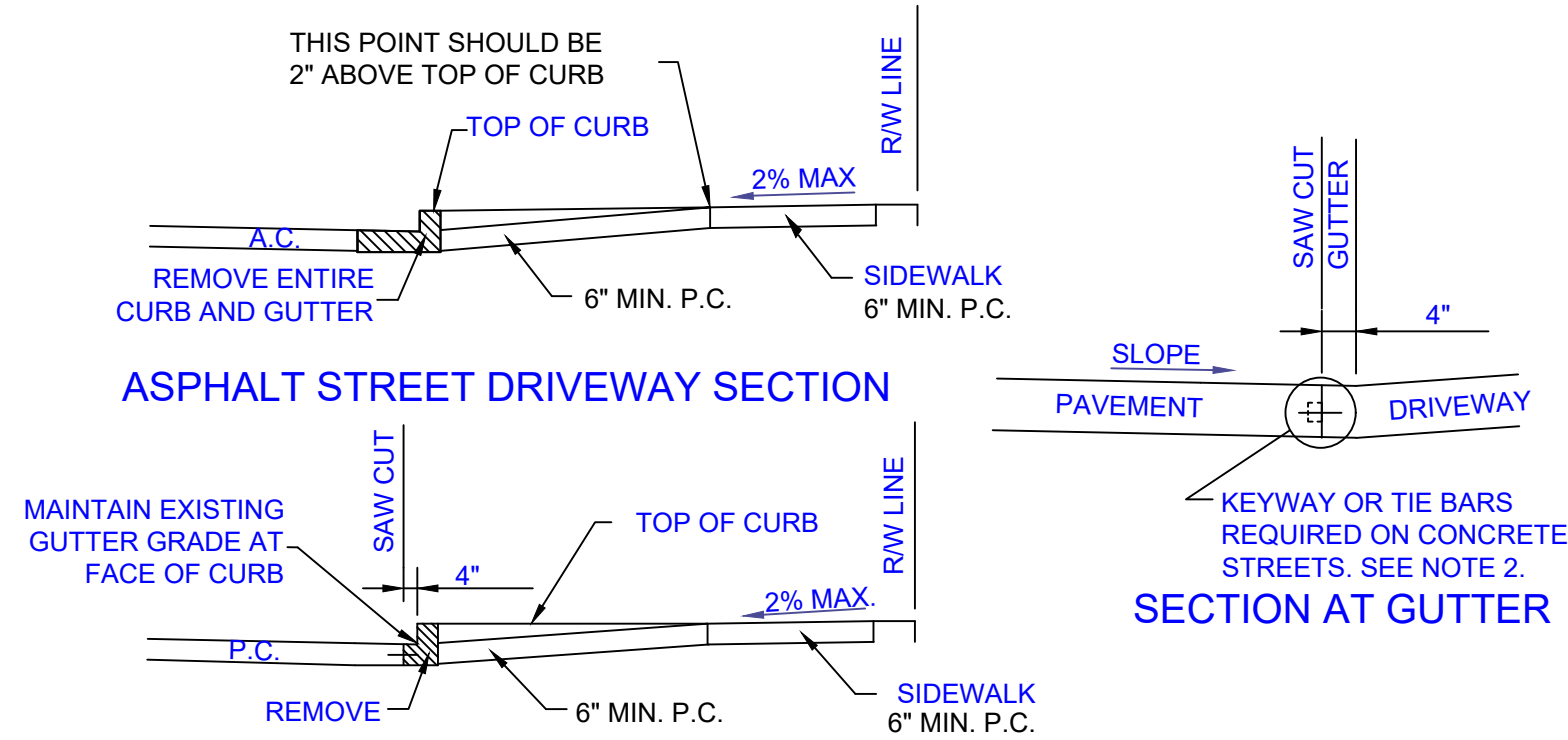
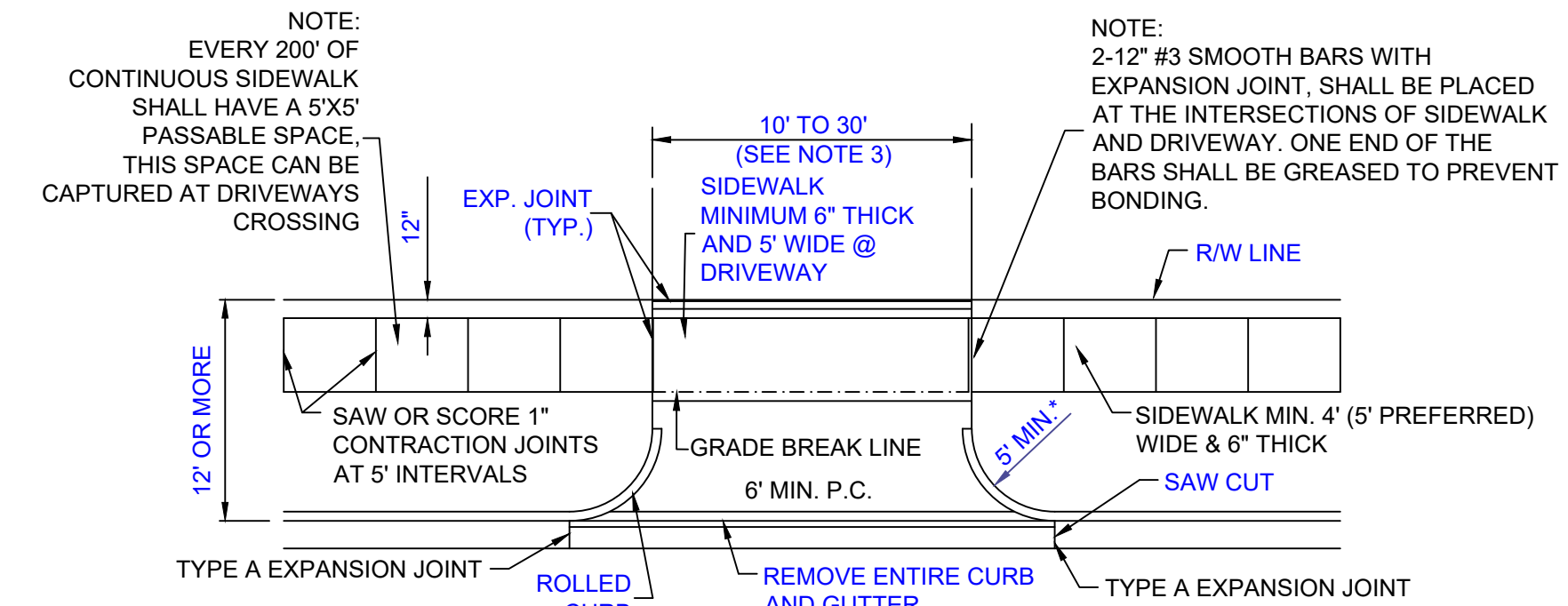

NOTES:

1. IF THE CONCRETE STREET IS CONSTRUCTED WITH A SEPARATE CURB AND GUTTER, THE ENTIRE CURB AND GUTTER SHALL BE REMOVED WHEN CONSTRUCTING A DRIVEWAY APPROACH.
2. IF CONCRETE DRIVEWAY APPROACH ABUTS A CONCRETE STREET OR MOUNTABLE CURB THE DRIVEWAY SHALL BE CONNECTED TO THE STREET OR CURB USING A KEYWAY OR TIE BARS. THE TIE BARS SHALL BE #4 BARS (18") LONG REQUIRED AT (24") CENTERS.
3. IN THE HISTORIC DISTRICT, THE MINIMUM DRIVEWAY WIDTH SHALL BE 8 FEET AND THE MAXIMUM 10 FEET. ALSO TWO STRIPS OF CONCRETE 18" WIDE SHALL BE ALLOWED.
4. SAW CUTS TO BE MADE IF DRIVEWAY WIDTH IS GREATER THAN 12'.
5. CONCRETE SURFACE TO BE MEDIUM BROOM FINISH.
6. DRIVEWAY TO BE CONSTRUCTED WITH CLASS A 3000 PSI CONCRETE OR CLASS AA 4000 PSI CONCRETE.

Use	Non-Residential		Residential	
	Arterial	Non-Arterial	Arterial	Non-Arterial
Roadway Frontage				
Minimum Distance from Intersecting Street	150 feet	120 feet	120 feet	80 feet
Minimum Distance from Parallel Driveways	30 feet	20 feet	20 feet	0 feet
Minimum Width	24 feet	24 feet	18 feet	12 feet
Maximum Width	30 feet	24 feet	24 feet	16-24 feet
Minimum Radius	15 feet	15 feet	10 feet	5 feet
Maximum Radius	25 feet	25 feet	15 feet	10 feet
Driveways separations will be measured from the nearest curb of adjacent streets or driveways				
A drive can be adjacent to a property line if it is a shared use driveway with the adjoining property				
Residential Driveways on Residential/Neighborhood Streets shall only be larger than 16' wide where the lots have >60 feet of frontage				
Wider Driveway widths and radius may be considered for industrial uses with City Engineer Approval				
All Driveways in non-rural areas should be built with ADA compliant crossings				
Base Zoning may have further restrictions on driveway width. Driveways offsets shall be measured from the nearest edge of the right of way to the edge of the driveway curbing.				

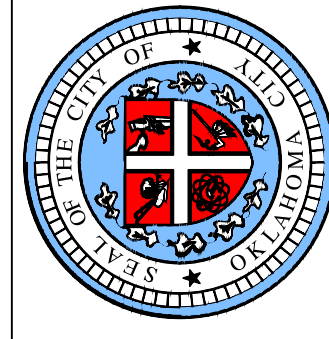

APPROVED BY: *Debbie Miller*
DEBBIE MILLER, P.E.
CITY ENGINEER

DRAWN: CH
DATE: 6/15/26
06-09-26

**STANDARD TYPICAL SECTION
DRIVEWAY DETAILS**

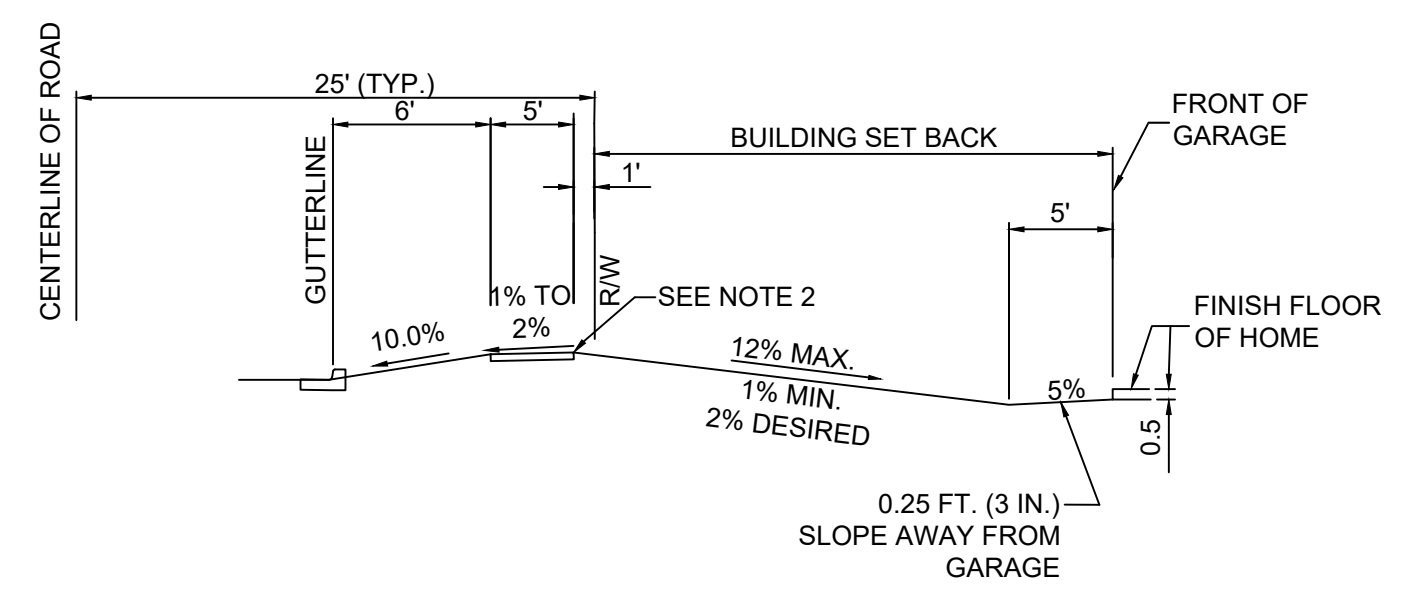

LOCAL RESIDENTIAL DRIVEWAY
(HOUSE BELOW STREET)

- NOTES:**
- MUST HAVE A MINIMUM OF 5% SLOPE (3" IN 5') AWAY FROM THE SIDES OF THE HOUSE FOR AT LEAST 5 FT.
 - THIS POINT IS .28 FT (3 3/8 IN) ABOVE TOP OF 6" CURB OR 0.78 FT. ABOVE GUTTER.
 - THIS IS A TYPICAL DRAWING. THIS DRAWING MAY BE AMENDED BY THE CITY ENGINEER ON A CASE BY CASE BASIS.

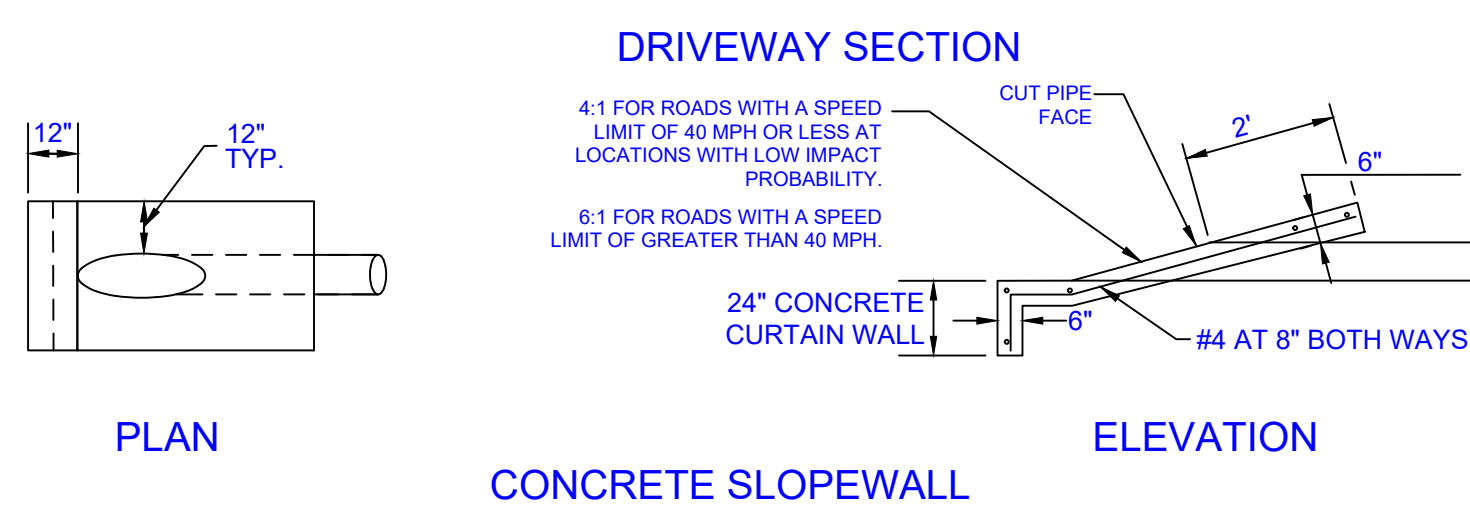

CONCRETE SLOEWALL

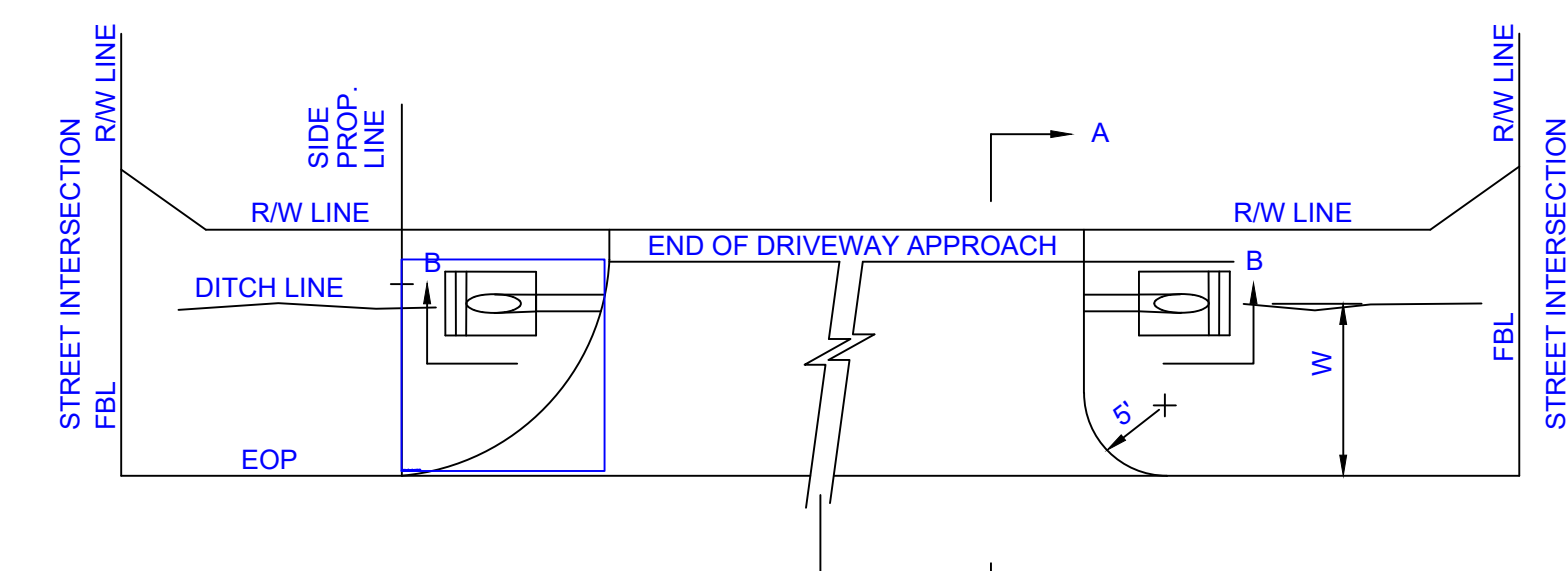

- NOTES:**
- FBL = FRONTAGE BOUNDARY LINE
 - EOP = EDGE OF PAVEMENT
 - EOS = EDGE OF SIDEWALK
 - NO DRIVEWAY RADIUS IS TO FALL WITHIN THE CORNER RADIUS.
 - DIMENSION "W" IS DEPENDENT ON THE CONTROLLING CRITERIA: ADJACENT DITCH FLOWLINE, REQUIRED COVER, OR FORESLOPE FROM THE ROADWAY EDGE OF PAVEMENT.

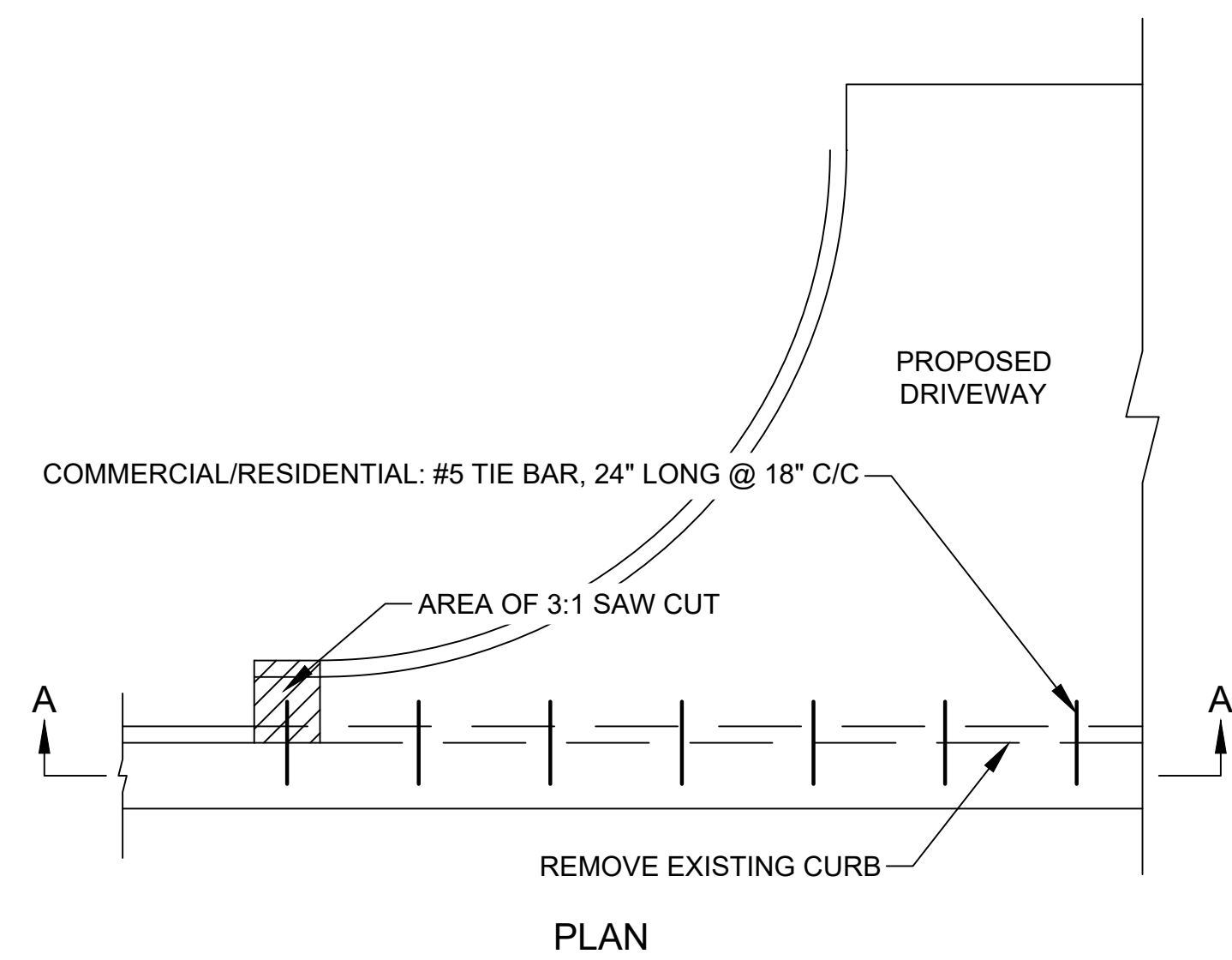

PLAN

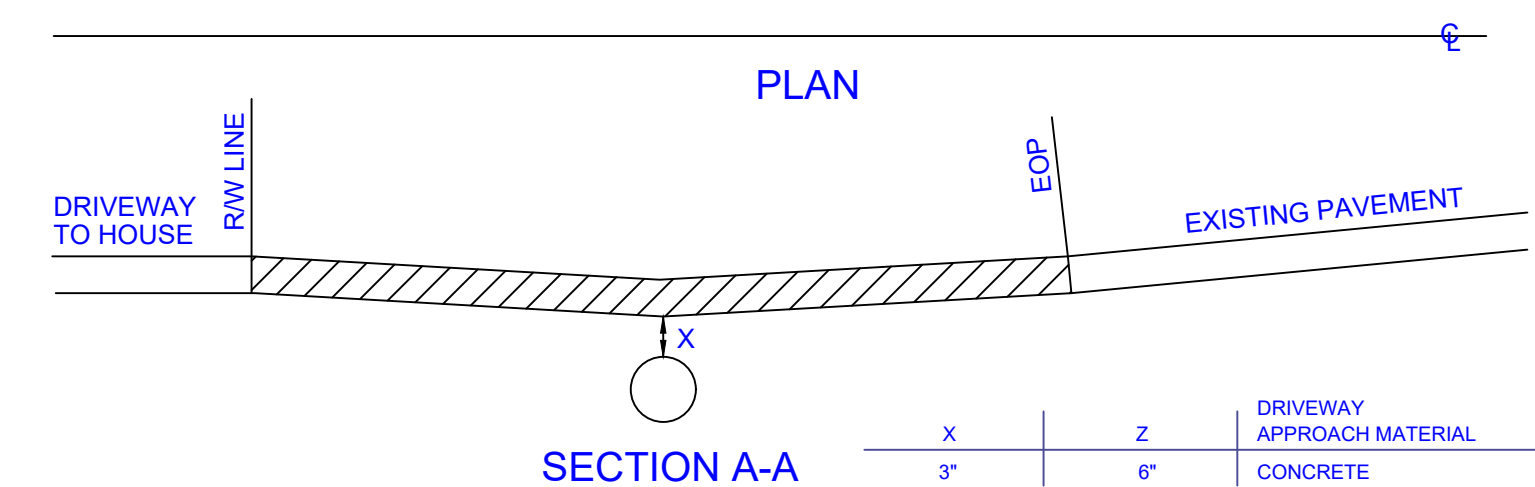

SECTION A-A

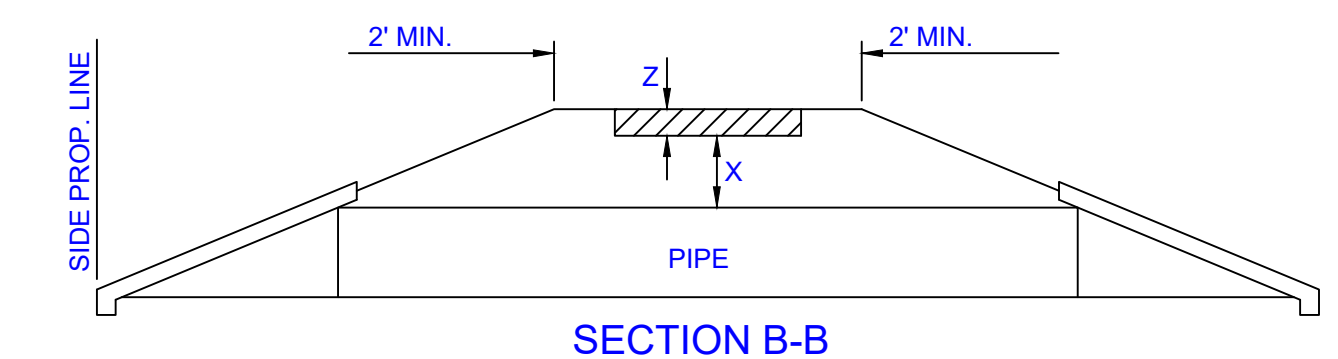

SECTION B-B

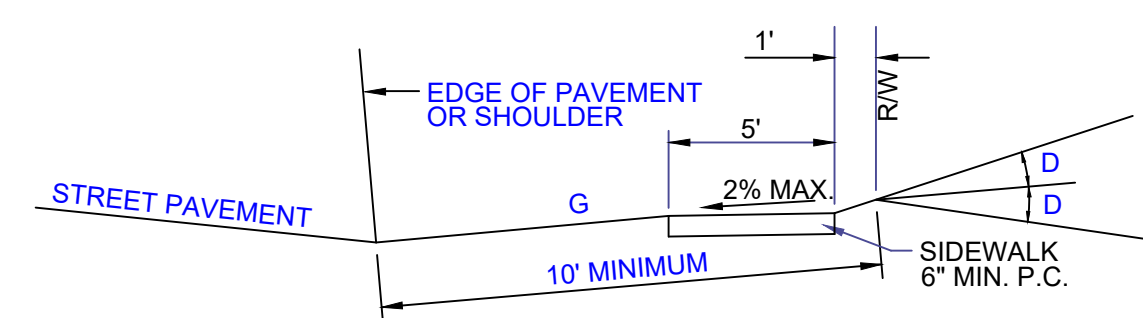

DRIVEWAY GRADES

ELEMENT	DRIVEWAY	FUNCTIONAL CLASSIFICATION		
		ARTERIAL	COLLECTOR	LOCAL
RECOMMENDED APPROACH GRADES (G)	RESIDENTIAL	DESIRABLE: 0-10%	MAXIMUM: 12%	
	COMMERCIAL/INDUSTRIAL	DESIRABLE: 0-5%	MAXIMUM: 8%	
CHANGE IN GRADE (D) WITHOUT VERTICAL CURVE	ALL	8% OR LESS	9% OR LESS	12% OR LESS

APPROACH GRADE

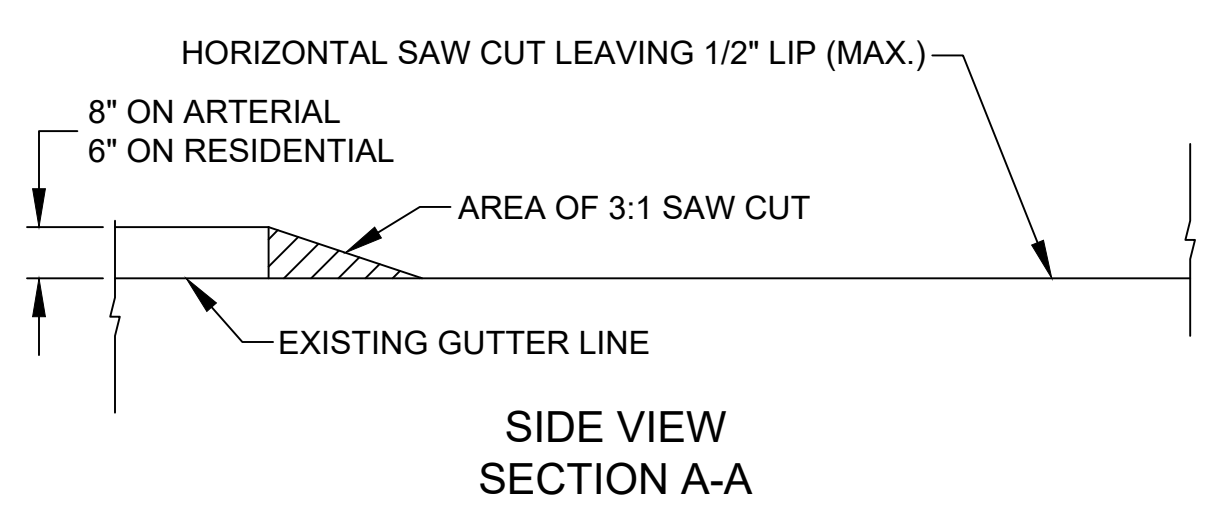

SIDE VIEW SECTION A-A

NOTE: MUST MEET OTHER DIMENSION REQUIREMENTS SHOWN ON D-300 A-E.

DRIVEWAY INSTALLATION WHEN SAWING & REMOVING EXISTING CURB

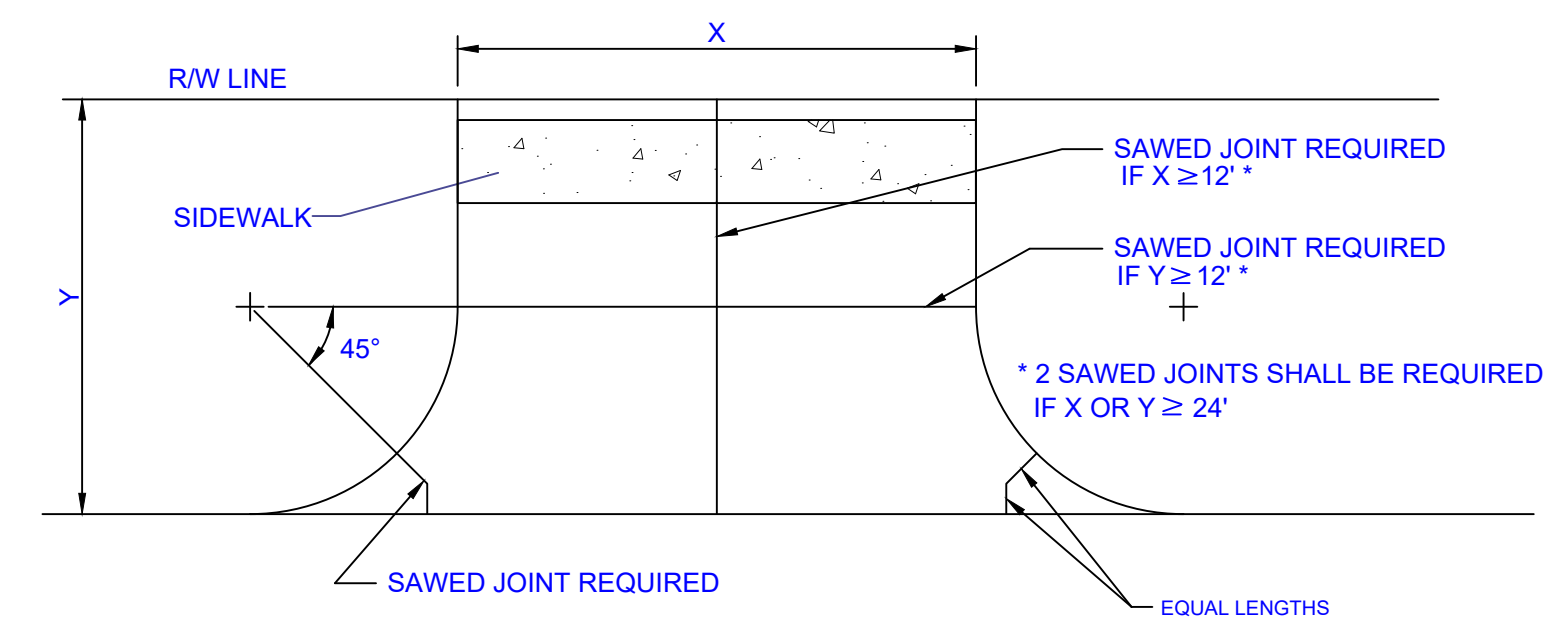

CONTRACTION JOINTS

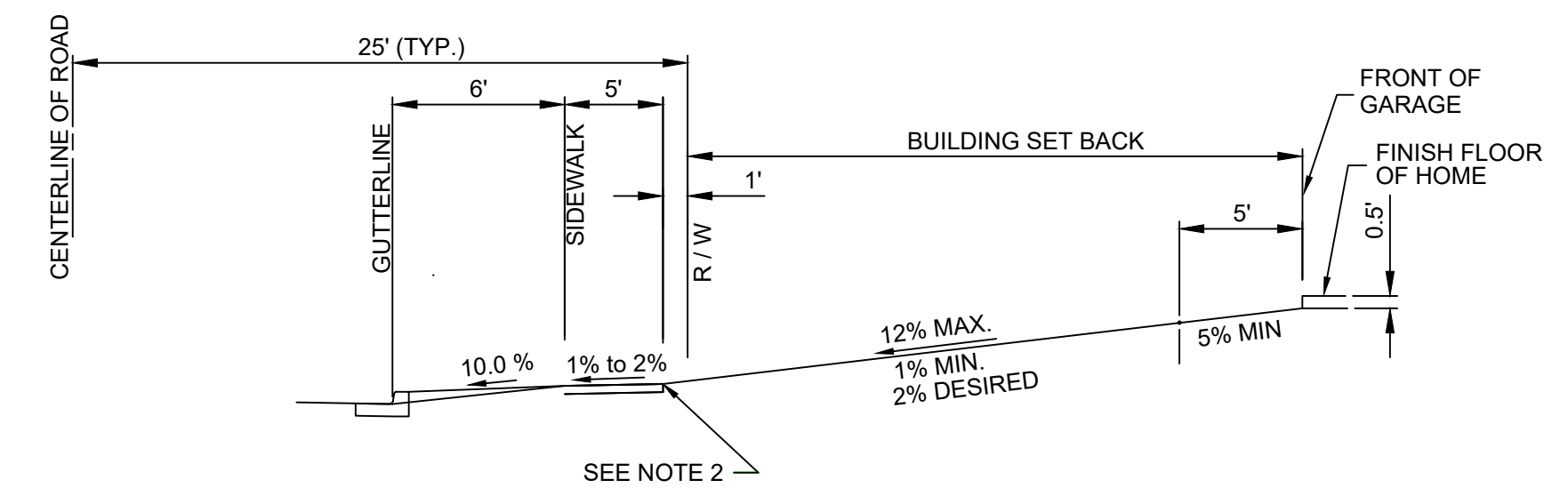

LOCAL RESIDENTIAL DRIVEWAY
(YARD SLOPES TO SIDEWALK)

- NOTES:**
- MUST HAVE A MINIMUM OF 5% SLOPE (3" IN 5') AWAY FROM THE SIDES OF THE HOUSE FOR AT LEAST 5 FT.
 - THIS POINT IS .28 FT (3 3/8 IN) ABOVE TOP OF 6" CURB OR 0.78 FT. ABOVE GUTTER.
 - THIS IS A TYPICAL DRAWING. THIS DRAWING MAY BE AMENDED BY THE CITY ENGINEER ON A CASE BY CASE BASIS.

C:\Users\comor.holland\OneDrive - City of Oklahoma City\Projects\Active\Standard Details\C3D\Drawings\D-300_DRAFT.dwg, 6/9/2026 8:07:26 AM

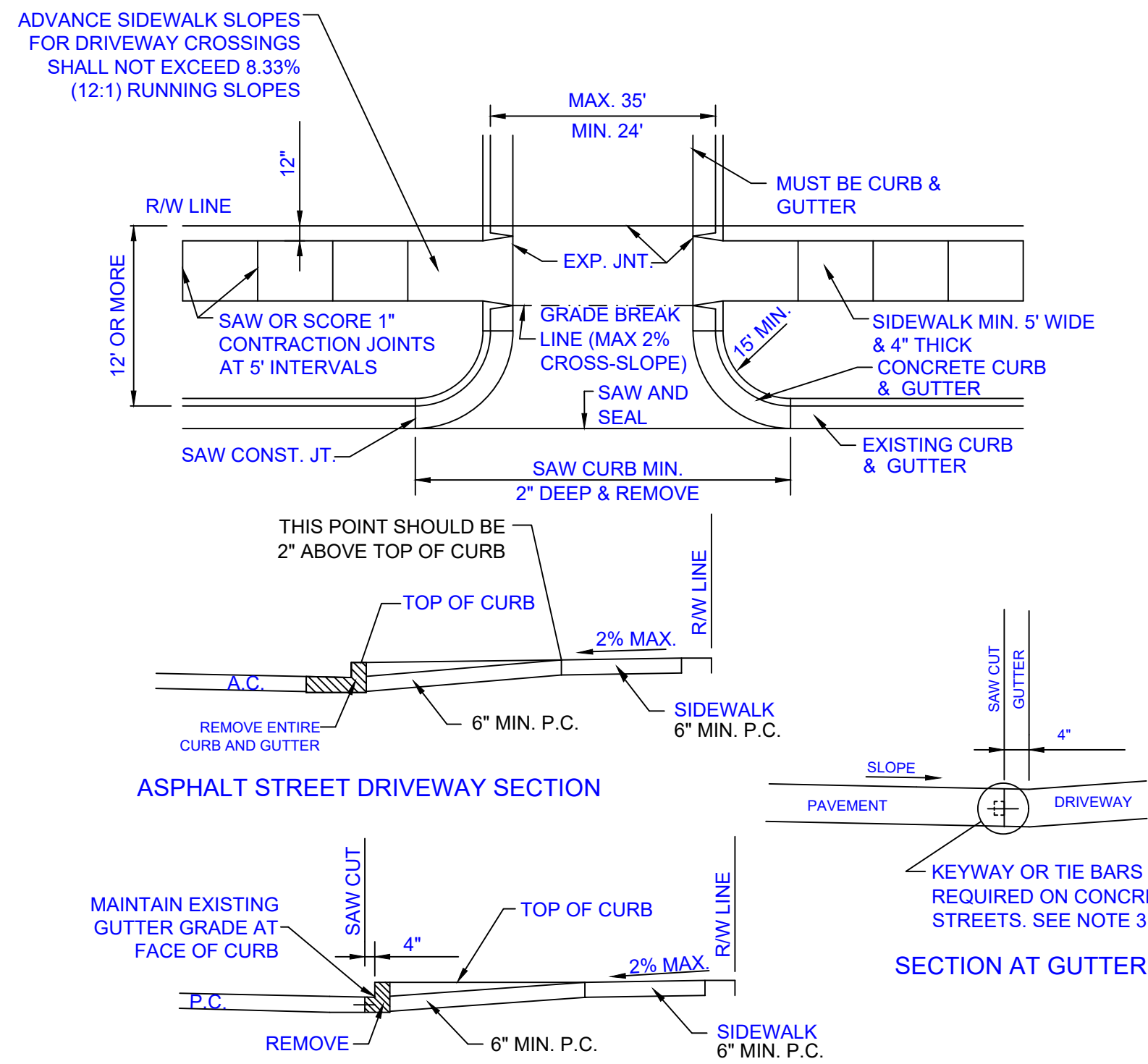

- NOTES:**
1. DRIVEWAY SHALL BE DESIGNED TO ACCOMMODATE LARGEST TRUCK TO USE IT.
 2. IF CONCRETE DRIVEWAY ABUTS AN ASPHALT STREET, SAWING AND SEALING WILL NOT BE REQUIRED. CONCRETE DRIVEWAY WILL NEED TO BE EDGED.
 3. IF CONCRETE DRIVEWAY ABUTS A CONCRETE STREET THE DRIVEWAY SHALL BE CONNECTED TO THE STREET USING A KEYWAY OR TIE BARS. THE TIE BAR SHALL BE #5 BARS 18" LONG REQUIRED AT 24" CENTERS.

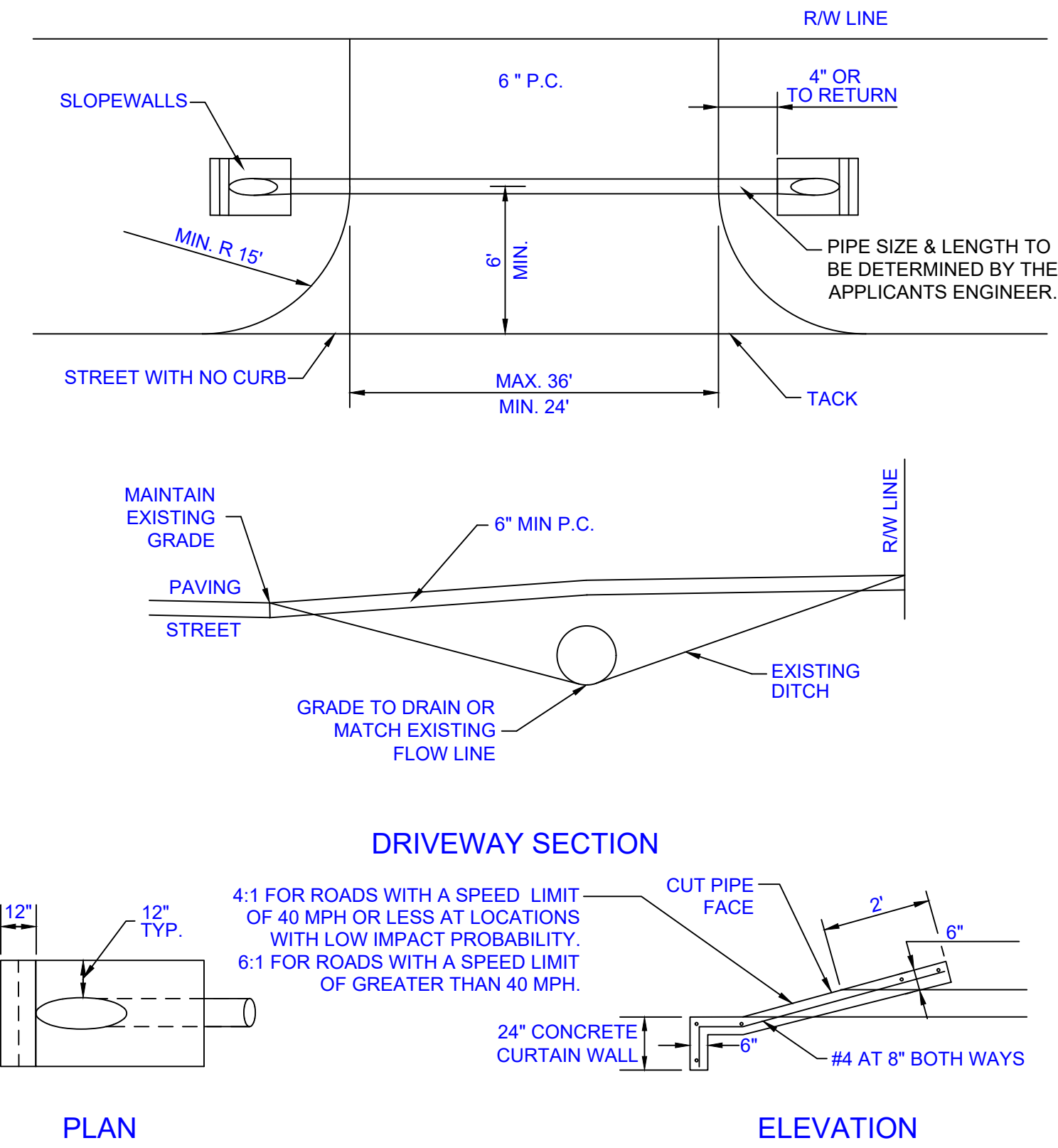

COMMERCIAL DRIVEWAY (NO CURB AND GUTTER)

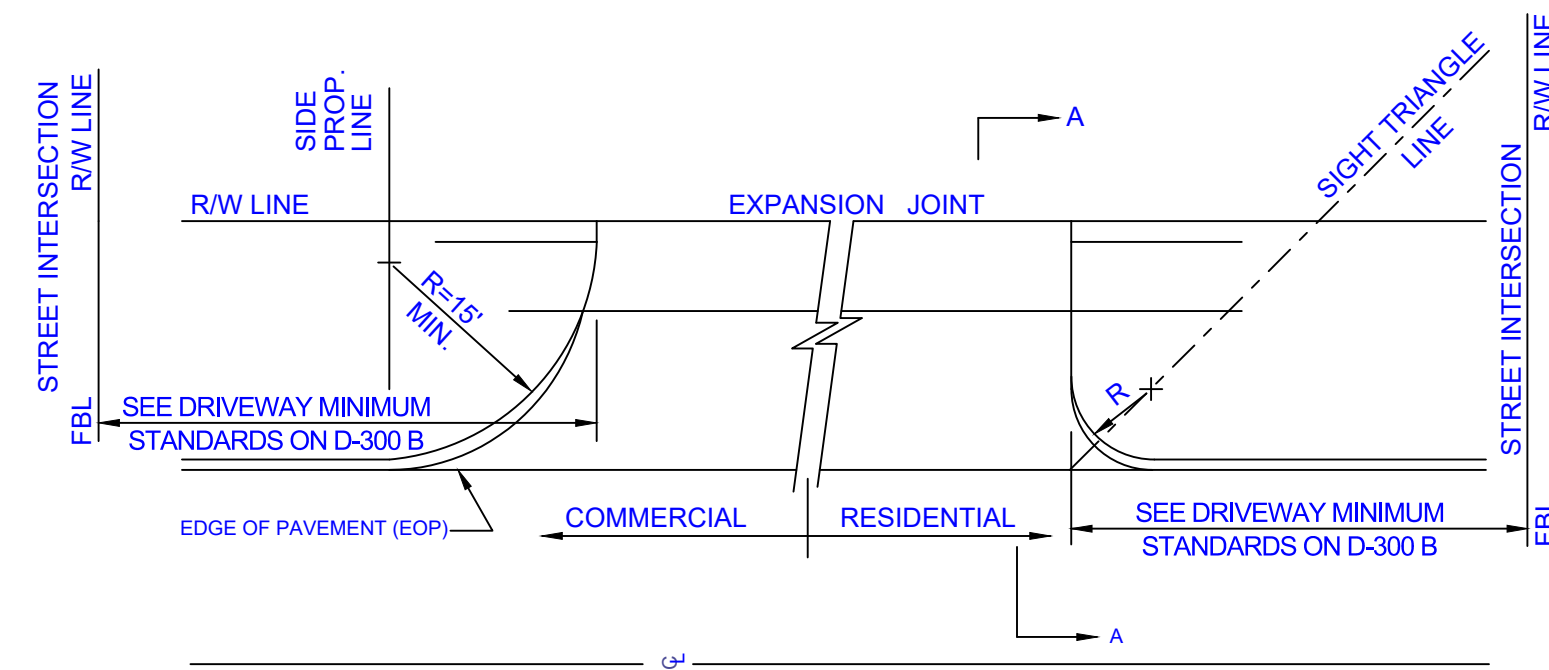

- NOTES:**
1. FBL = FRONTAGE BOUNDARY LINE
 2. NO DRIVEWAY RADIUS IS TO FALL WITHIN THE CORNER RADIUS.

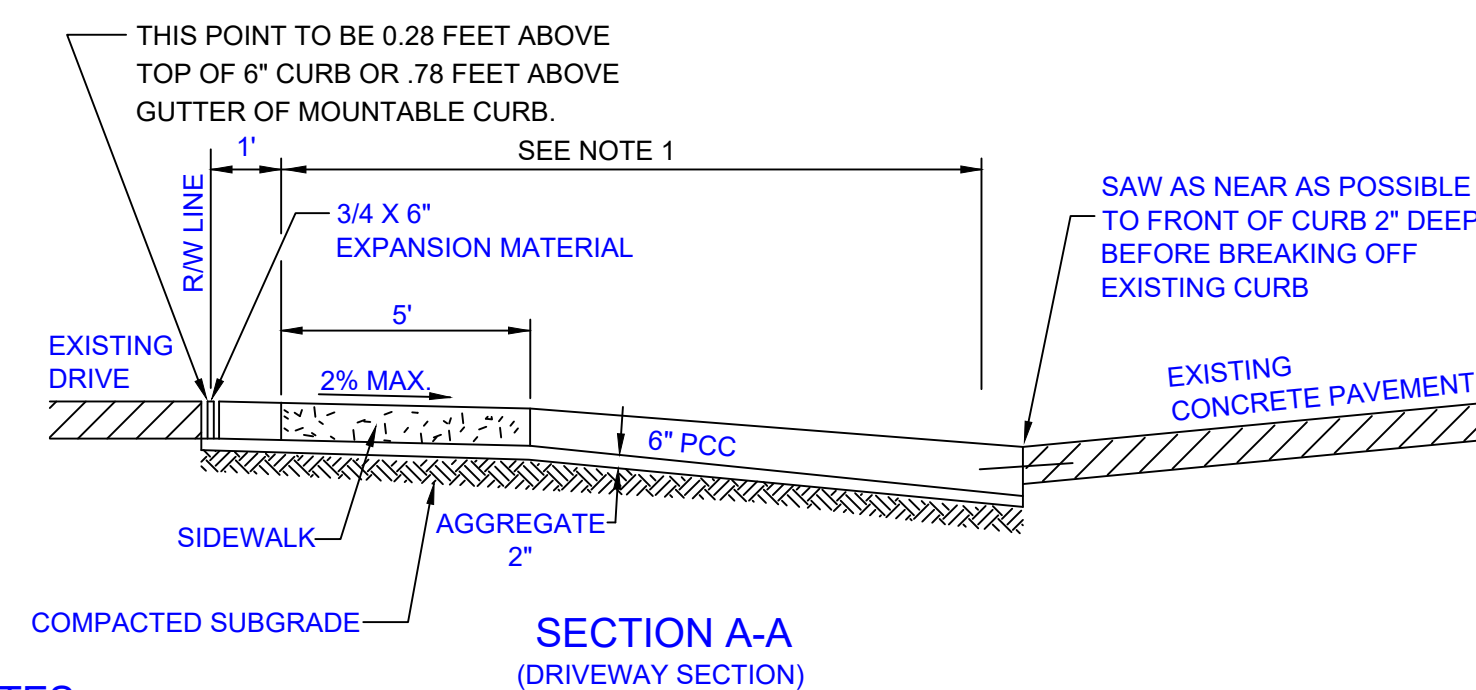

- NOTES:**
1. TYPICALLY 23.33 FEET FOR COMMERCIAL DRIVEWAY (SEE NOTE 2), 11.33 FEET FOR RESIDENTIAL DRIVEWAY ON LOCAL STREET AND 12.33 FEET FOR RESIDENTIAL DRIVEWAY ON A COLLECTOR STREET.
 2. IF CONCRETE DRIVEWAY APPROACH ABUTS A CONCRETE STREET OR MOUNTABLE CURB THE DRIVEWAY SHALL BE CONNECTED TO THE STREET OR CURB USING A KEYWAY OR TIE BARS. THE TIE BARS SHALL BE #5 BARS (18") LONG REQUIRED AT (24") CENTERS.

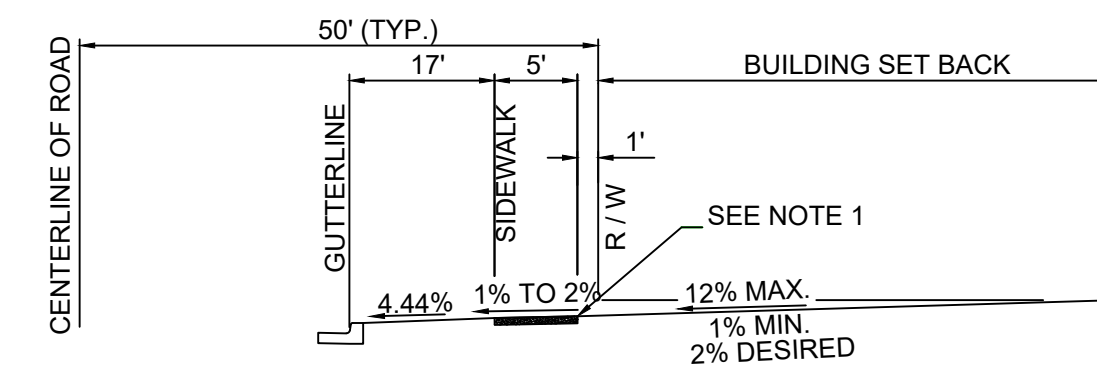

- NOTES**
1. THIS POINT IS AT LEAST 0.38 FT. (4 1/2") ABOVE TOP OF 6" CURB OR 0.88 FT. ABOVE GUTTER.
 2. IN COMMERCIAL AREAS, THERE WILL BE A 10 FT. OR 25 FT. SET BACK. THE MAXIMUM FINISH ELEVATION OF THE PARKING AREA ABOVE THE GUTTER LINE WILL CARRY AND WILL BE DETERMINED ON A CASE BY CASE BASIS BY THE CITY ENGINEER.

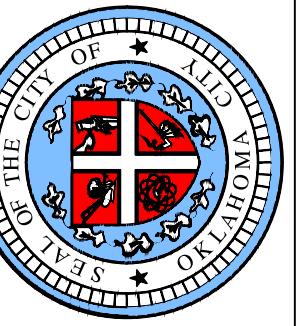

APPROVED BY: *Debbie Miller* DATE: 6/15/26
CITY ENGINEER
DRAWN: CH DATE: 06-09-26

STANDARD TYPICAL SECTION
DRIVEWAY DETAILS

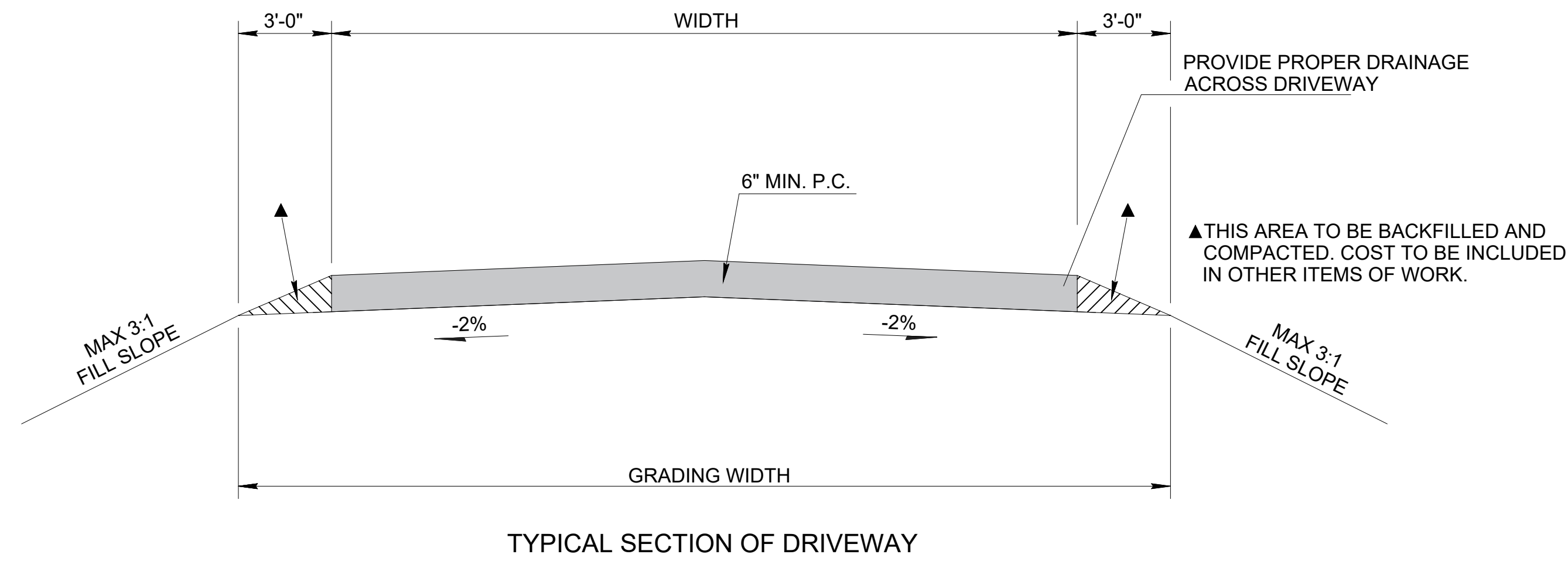

TYPICAL SECTION OF DRIVEWAY

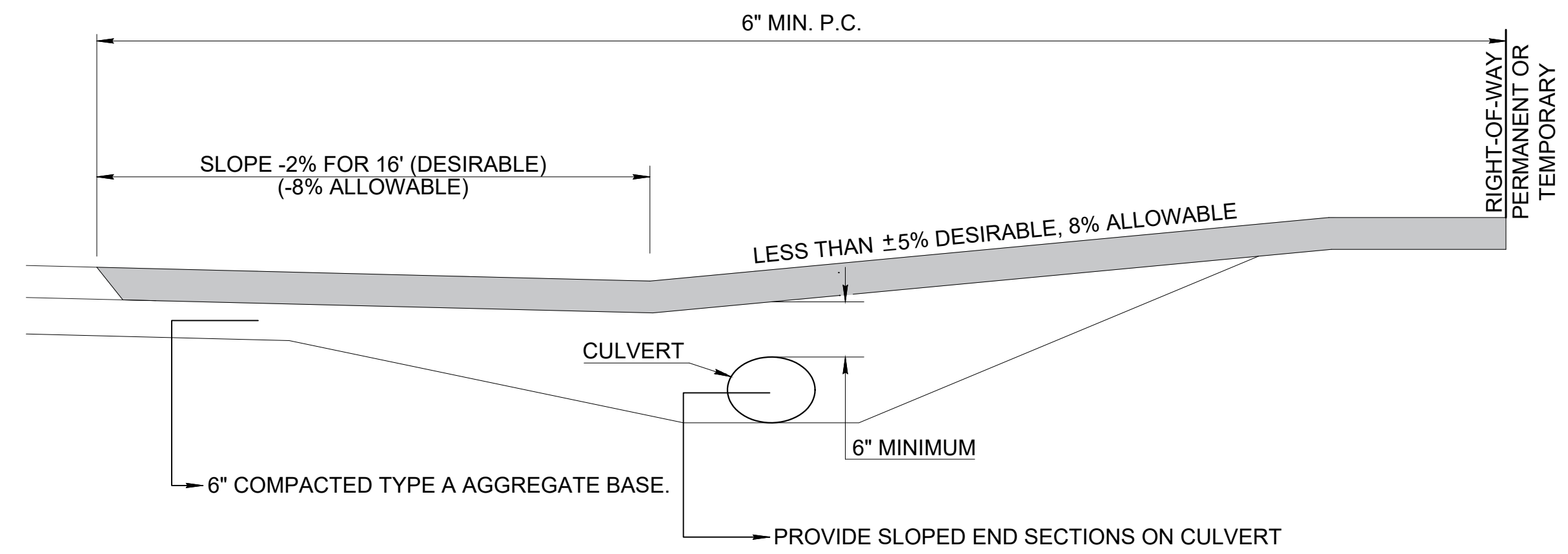

PROFILE OF TYPICAL DRIVEWAY ON ROADWAY CUT SECTION

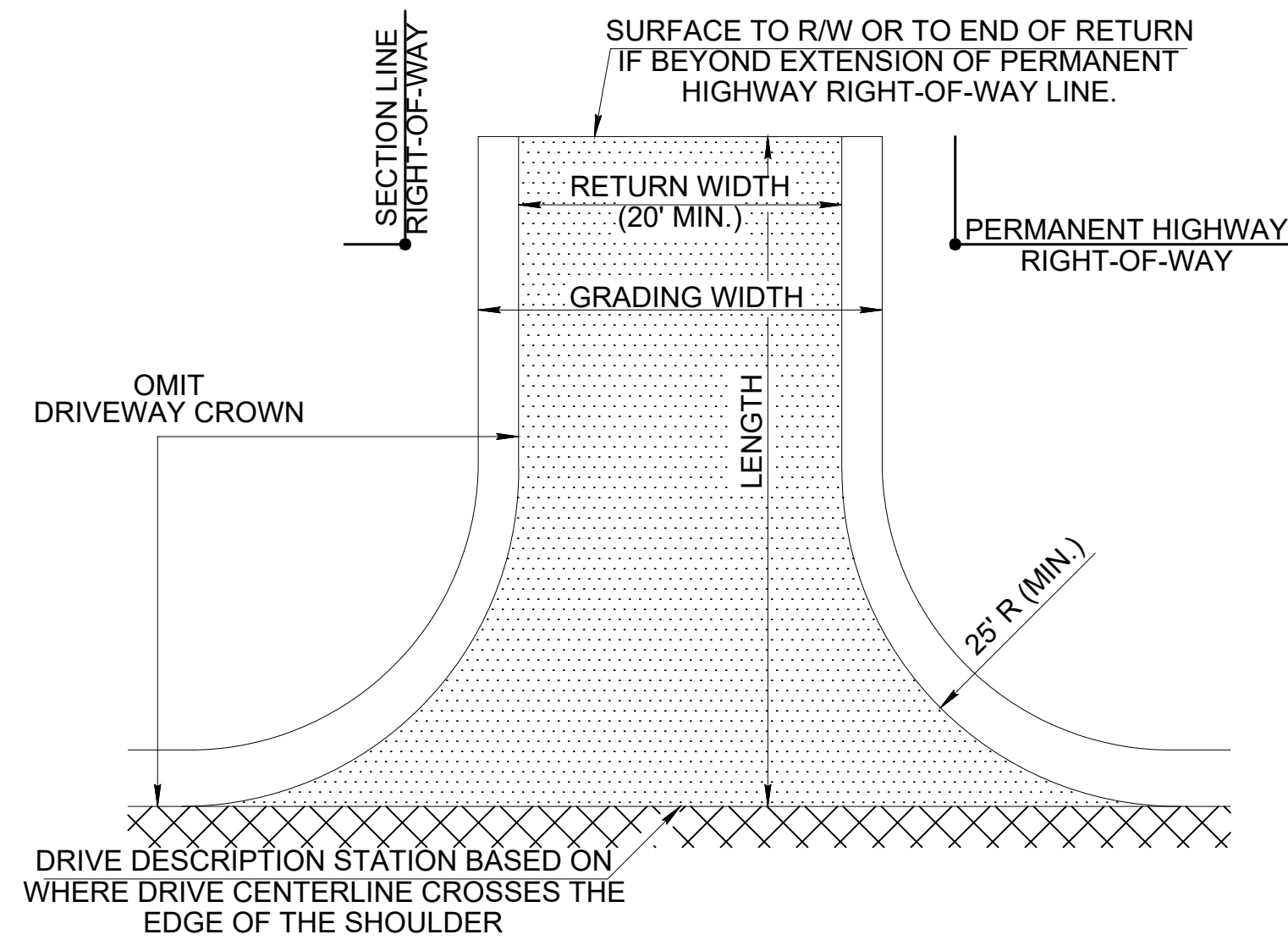

PLAN TYPICAL SECTION LINE RETURN

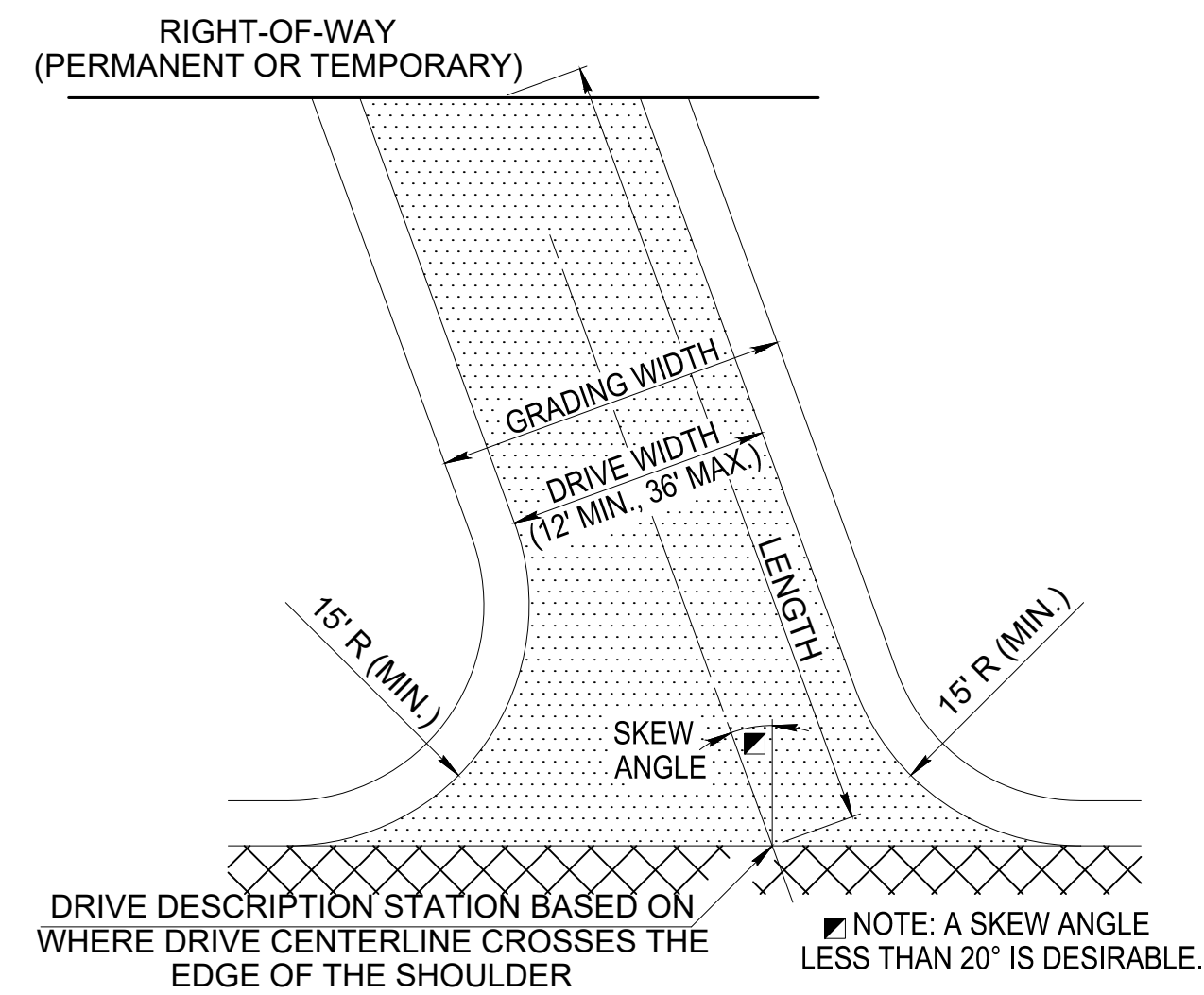

PLAN TYPICAL DRIVE ON SKEW

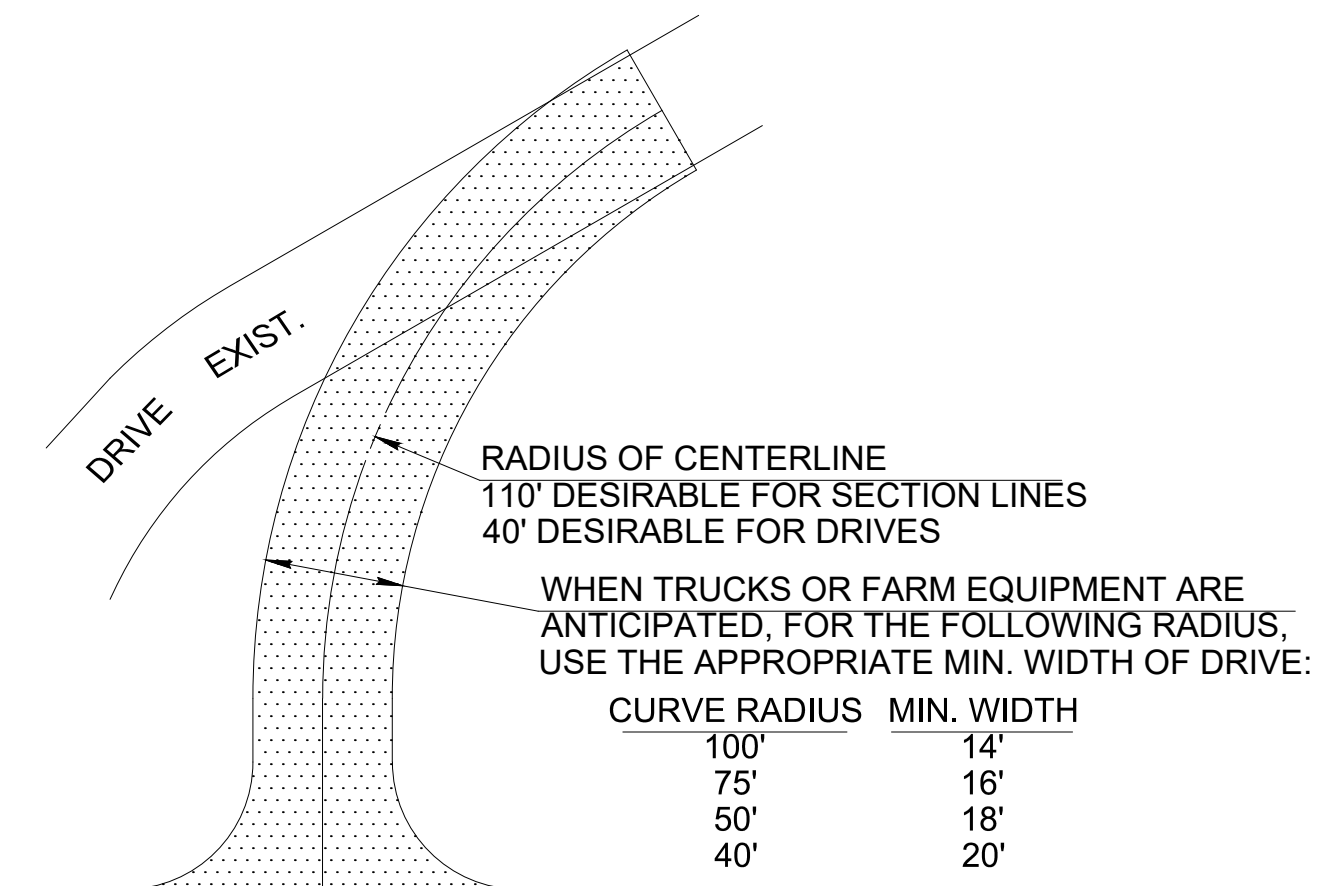

SECTION LINE OR DRIVE WITH CURVED ALIGNMENT

PROPOSED DRIVES AND RETURNS SHALL MATCH EXISTING EXCEPT WHEN SKEW ANGLE EXCEEDS 20 DEGREES. IT IS THEN DESIRED TO SHIFT THE LOCATION AND CONSTRUCT USING CURVED ALIGNMENT

USEFUL ABBREVIATIONS FOR PLAN SHEETS:

ASPH.	ASPHALT
T.B.S.C.	TRAFFIC BOUND SURFACE COARSE
CONC.	CONCRETE
SEC. RET.	SECTION LINE RETURN
FIELD ENT.	FIELD ENTRANCE
PVT. DRIVE	PRIVATE DRIVE
COMM. DRIVE	COMMERCIAL DRIVE
W/S.D.	WITH SIDE DRAIN
AS DIKE	AS DIKE ACROSS DITCH

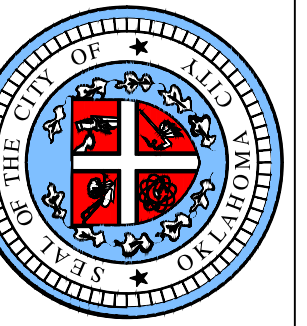

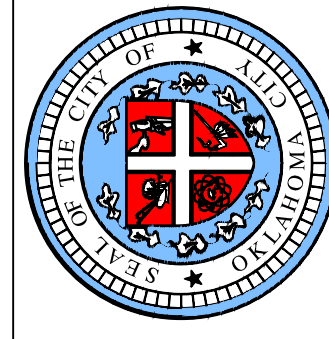

APPROVED BY: DATE: 02-05-13
 ERIC J. WENGER, P.E.
 CITY ENGINEER

DRAWN: VSC

DATE: 02-05-13

**STANDARD DETAILS FOR
 CUL-DE-SACS**

Drawing Number
 D-400

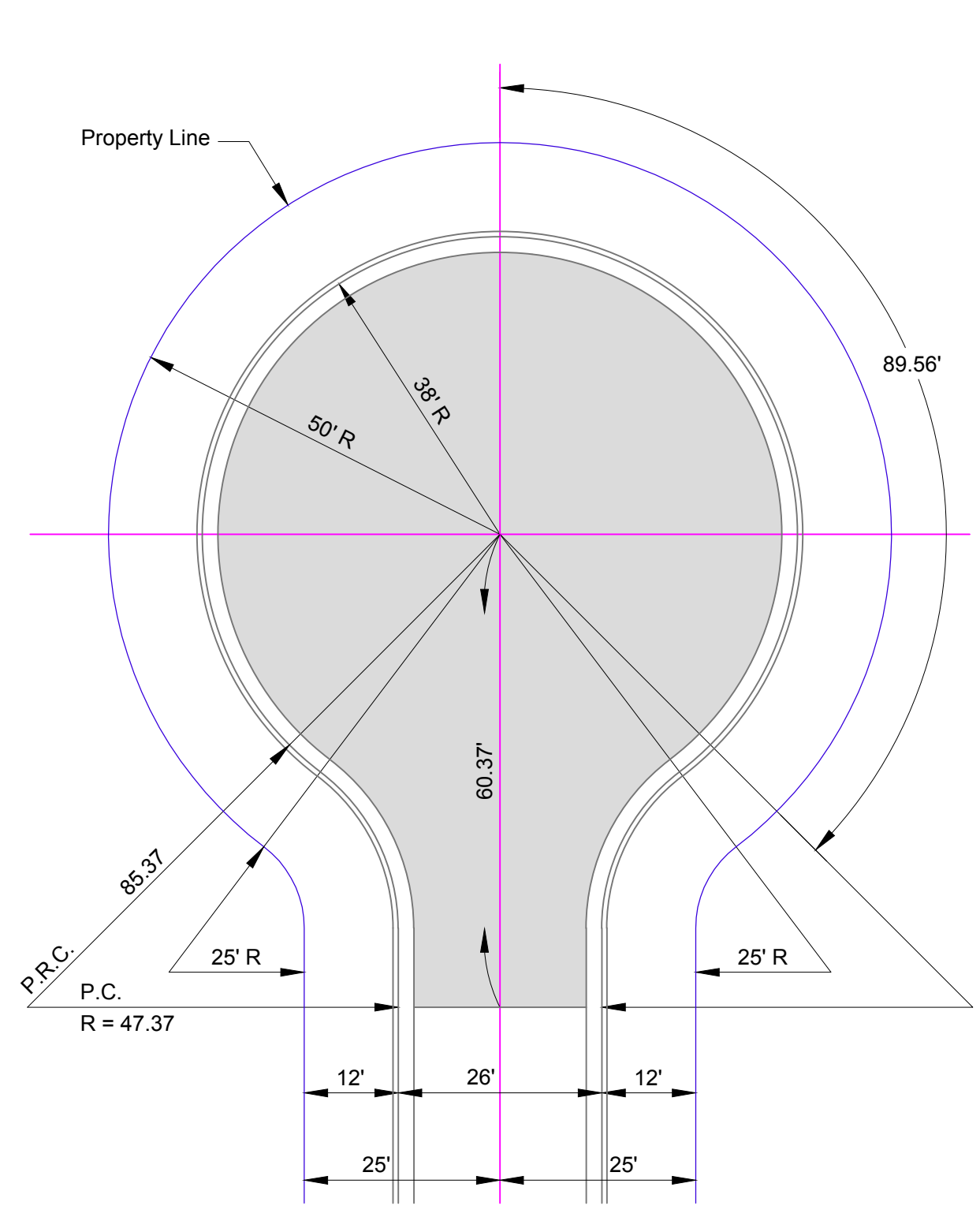

MATERIAL IN SAC BEYOND P.C.
 531.6 S.Y. ASPHALTIC CONCRETE
 587.9 S.Y. P.C. CONCRETE
 646.9 S.Y. BASE (10" Back of Curb)
 253.52 L.F. CURB

CURVE DATA
 $\Delta = 45^\circ$
 $R = 47.37'$
 $T = 19.62'$
 $L = 37.20'$

STANDARD CUL-DE-SAC -- 38' R

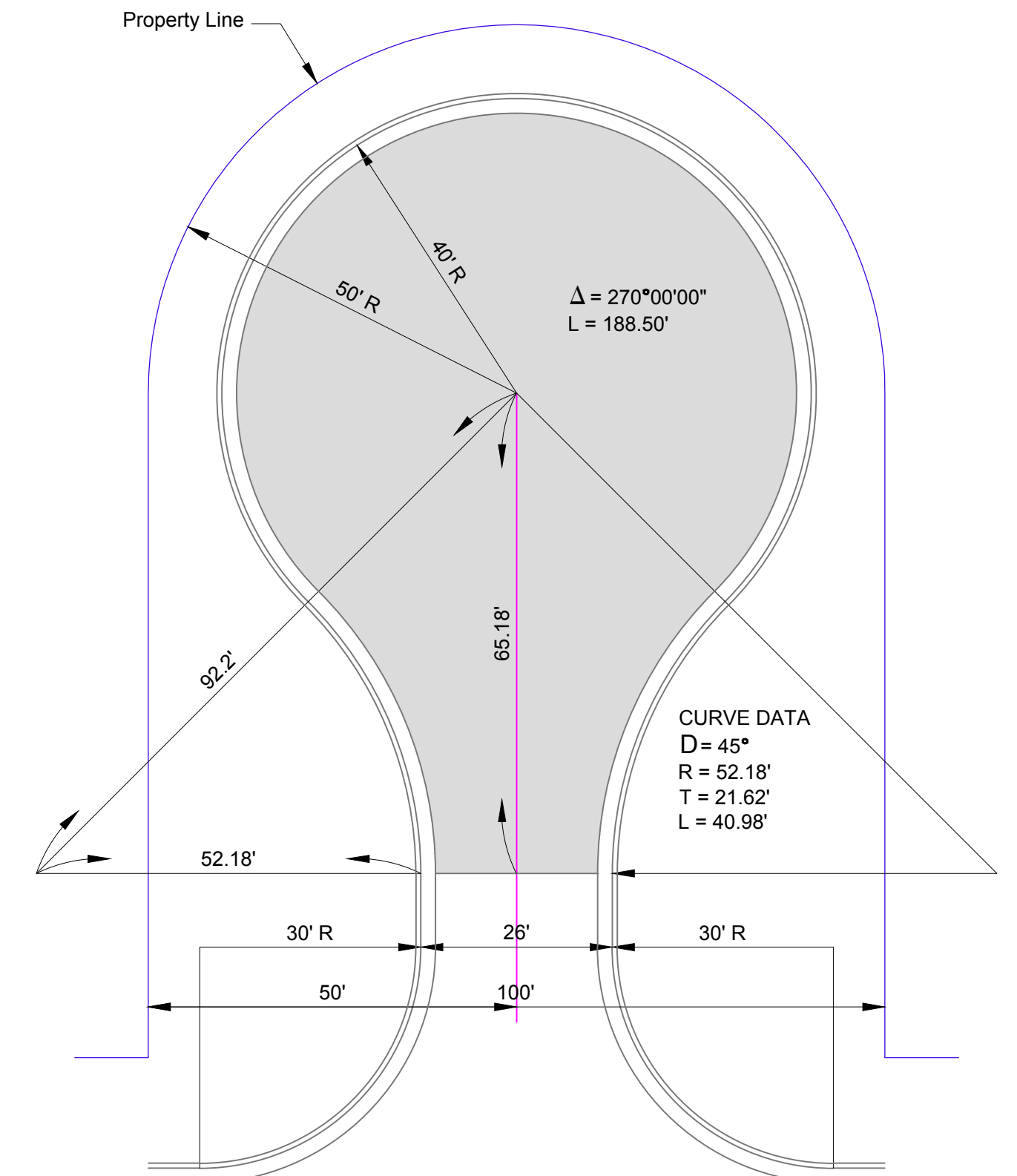

P.C. CONCRETE
 270.46 L.F. CONCRETE
 653.32 S.Y. P.C. CONCRETE
 702.10 S.Y. BASE (Includes to 10" Back of Curb)

ASPHALTIC CONCRETE
 270.46 L.F. CONCRETE & GUTTER
 593.92 S.Y. ASPHALTIC CONCRETE
 702.10 S.Y. BASE (Includes to 10" Back of Curb)

CURVE DATA
 $D = 45^\circ$
 $R = 52.18'$
 $T = 21.62'$
 $L = 40.98'$

STANDARD CUL-DE-SAC -- 40' R

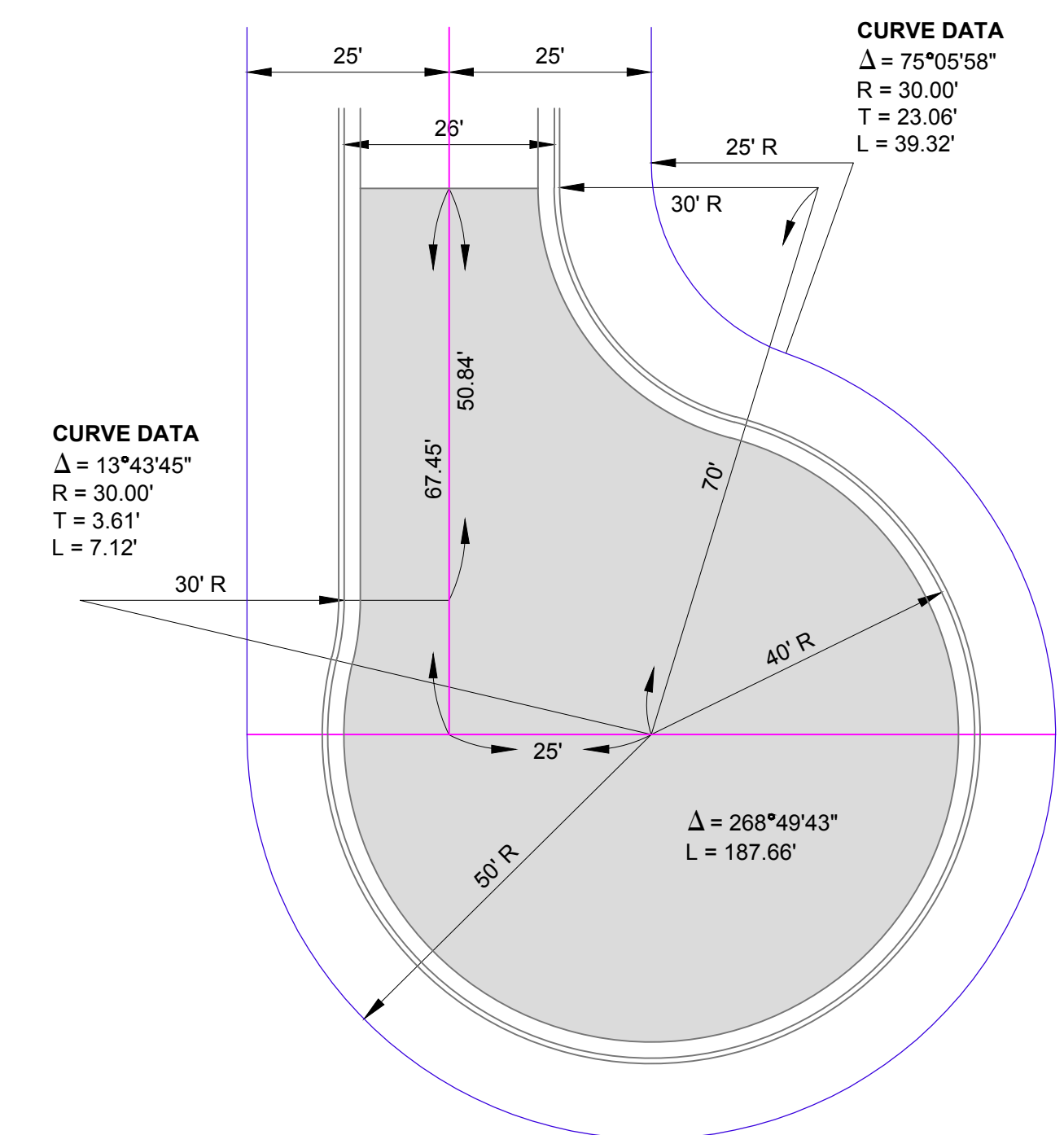

CURVE DATA
 $\Delta = 75^\circ 05' 58''$
 $R = 30.00'$
 $T = 23.06'$
 $L = 39.32'$

CURVE DATA
 $\Delta = 13^\circ 43' 45''$
 $R = 30.00'$
 $T = 3.61'$
 $L = 7.12'$

CURVE DATA
 $\Delta = 268^\circ 49' 43''$
 $L = 187.66'$

P.C. CONCRETE
 289.94 L.F. CONCRETE
 684.40 S.Y. P.C. CONCRETE
 735.75 S.Y. BASE (Includes to 10" Back of Curb)

ASPHALTIC CONCRETE
 289.94 L.F. CONCRETE & GUTTER
 621.77 S.Y. ASPHALTIC CONCRETE
 735.75 S.Y. BASE (Includes to 10" Back of Curb)

OFF-SET CUL-DE-SAC

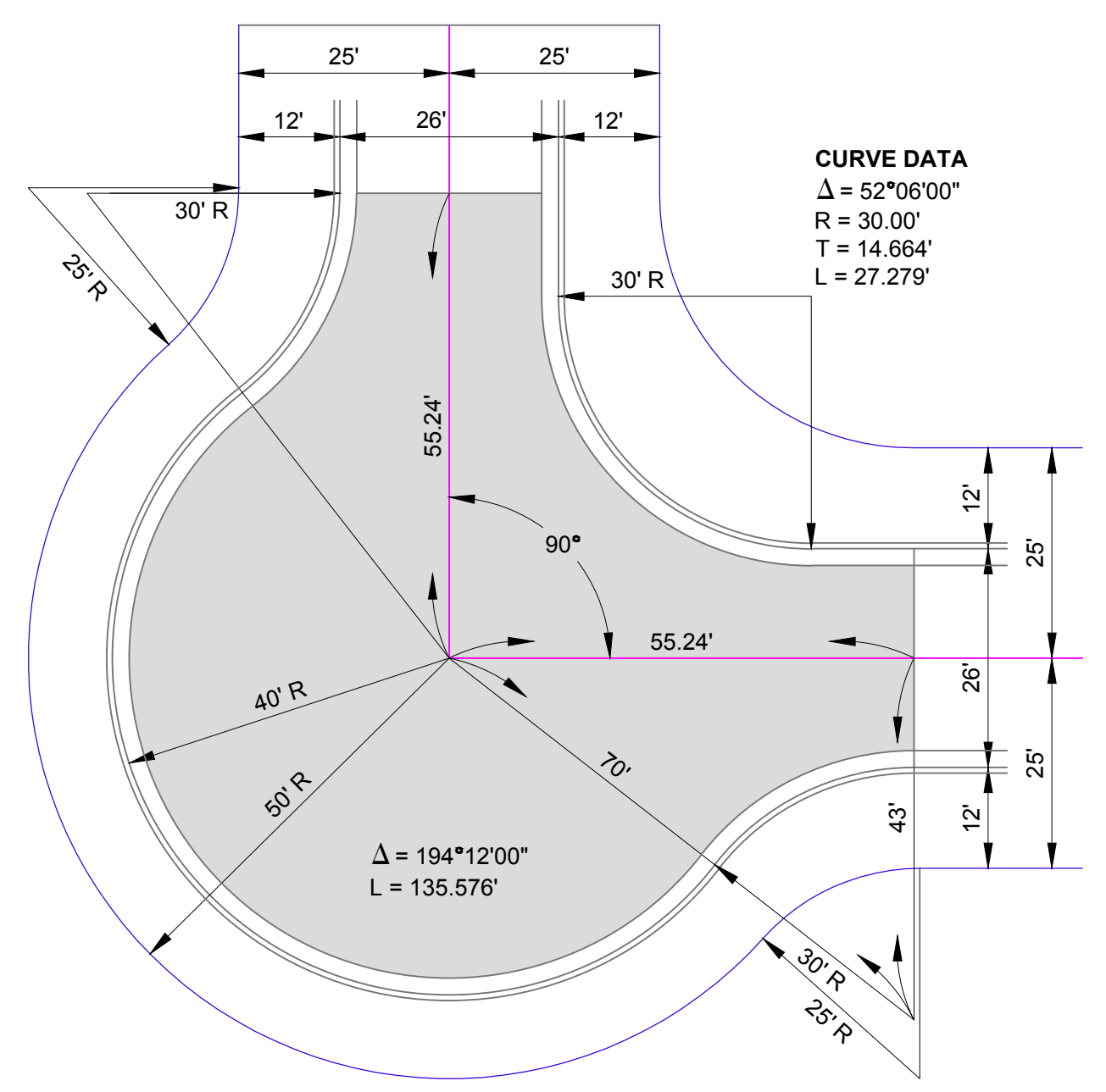

P.C. CONCRETE
 261.74 L.F. CONCRETE
 678.56 S.Y. P.C. CONCRETE
 683.10 S.Y. BASE (Includes to 10" Back of Curb)

ASPHALTIC CONCRETE
 261.74 L.F. CONCRETE & GUTTER
 578.40 S.Y. ASPHALTIC CONCRETE
 683.10 S.Y. BASE (Includes to 10" Back of Curb)

CURVE DATA
 $\Delta = 52^\circ 06' 00''$
 $R = 30.00'$
 $T = 14.664'$
 $L = 27.279'$

90° CUL-DE-SAC

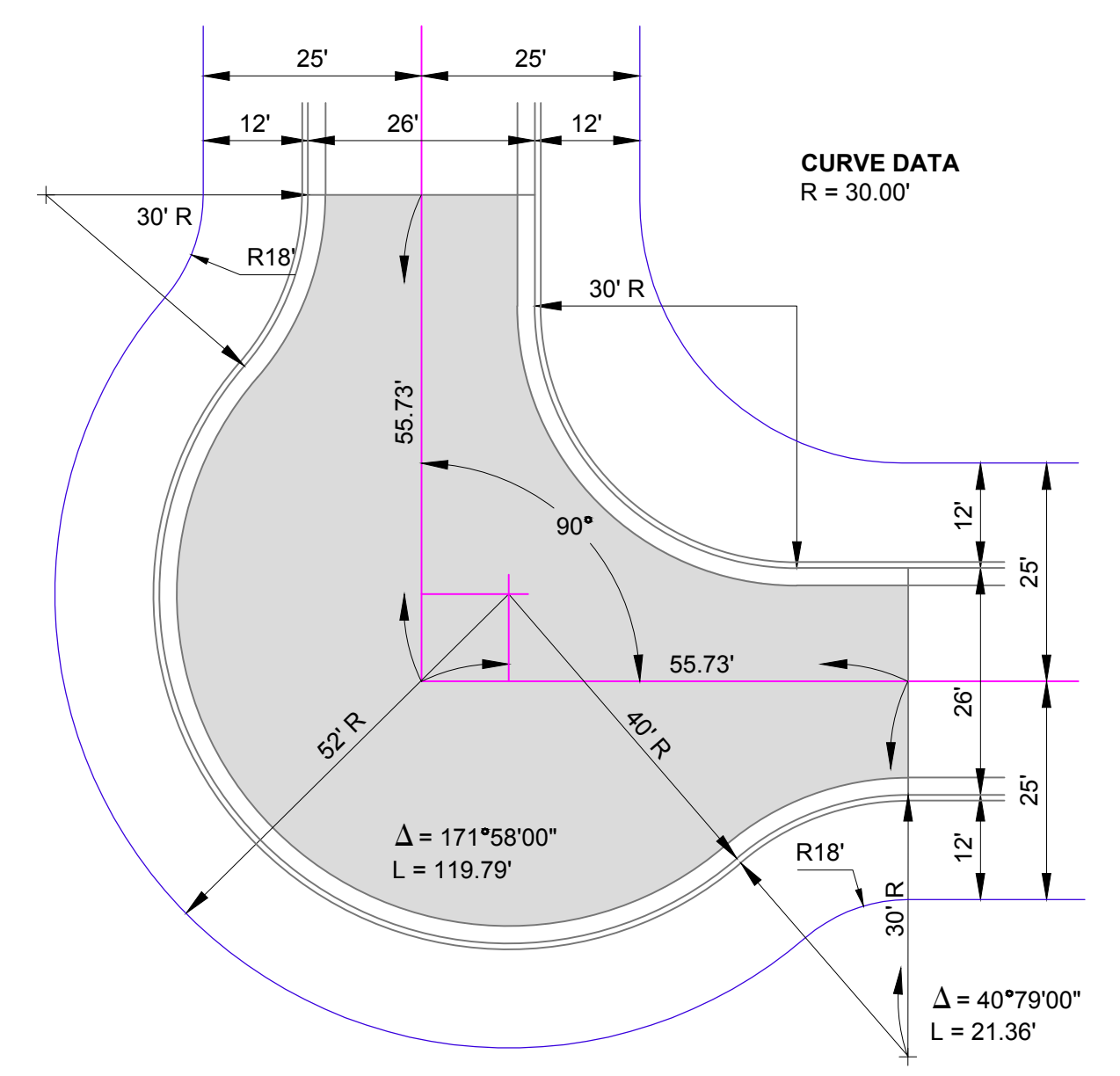

P.C. CONCRETE
 27.64 LF curb shorter w/ 10" offset.
 Approx. 91 sq smaller area.

ASPHALTIC CONCRETE
 234.97 L.F. CONCRETE & GUTTER

CURVE DATA
 $R = 30.00'$

90° CUL-DE-SAC

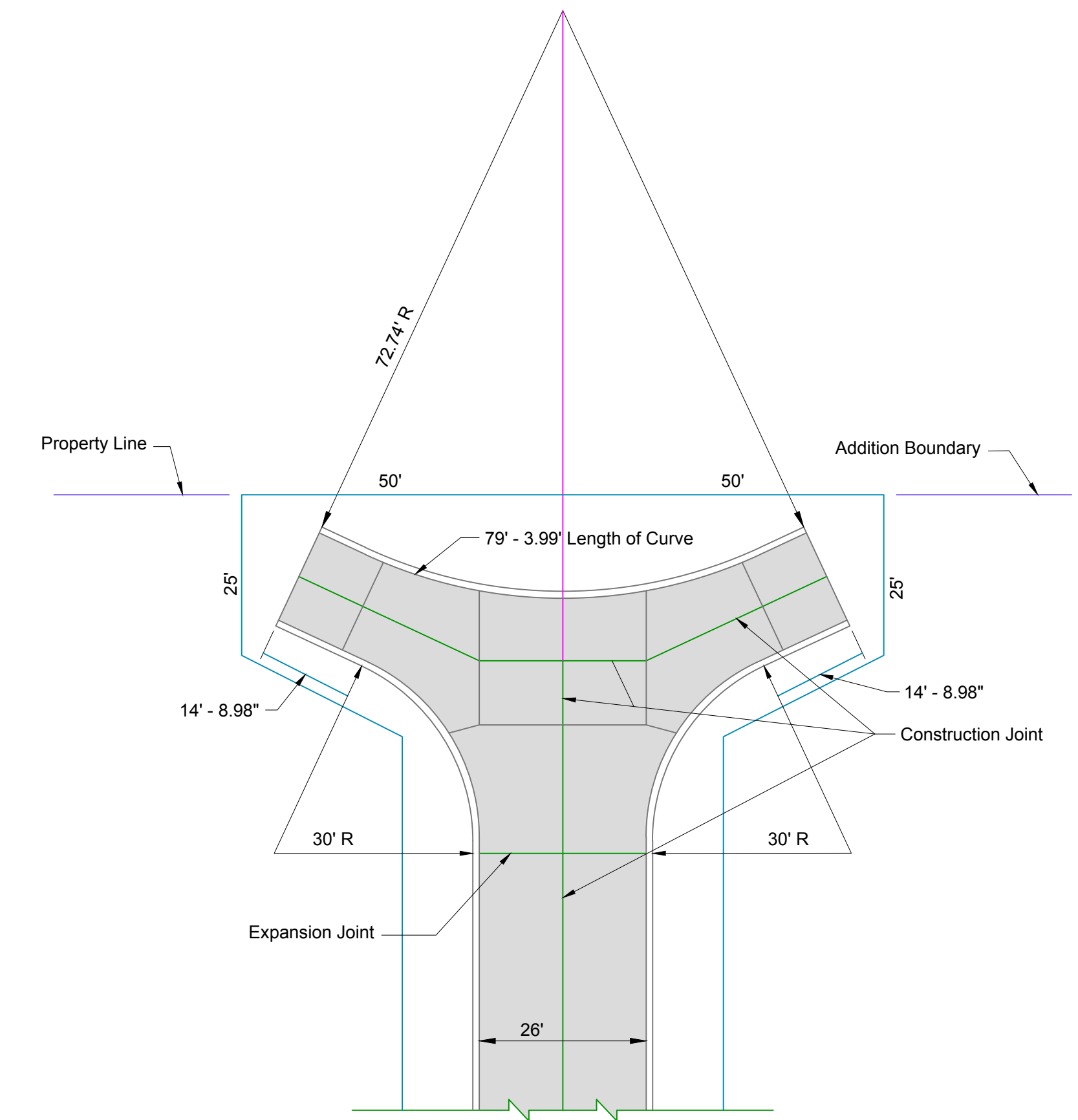

STANDARD "T" TURN AROUND

\\ci.okc\okc\pw-cad\nguyen\Drawing\Hanger B\STANDARD\APPROVED\SIDEWALK HANDRAIL DETAIL-U.dwg, 4/12/2023 12:36:26 PM, DWG To PDF.pc3

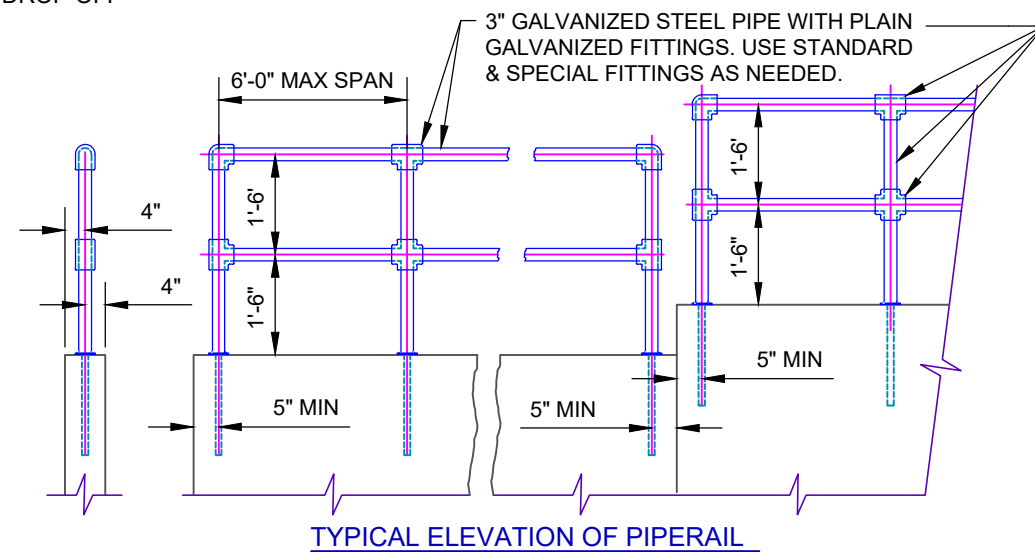
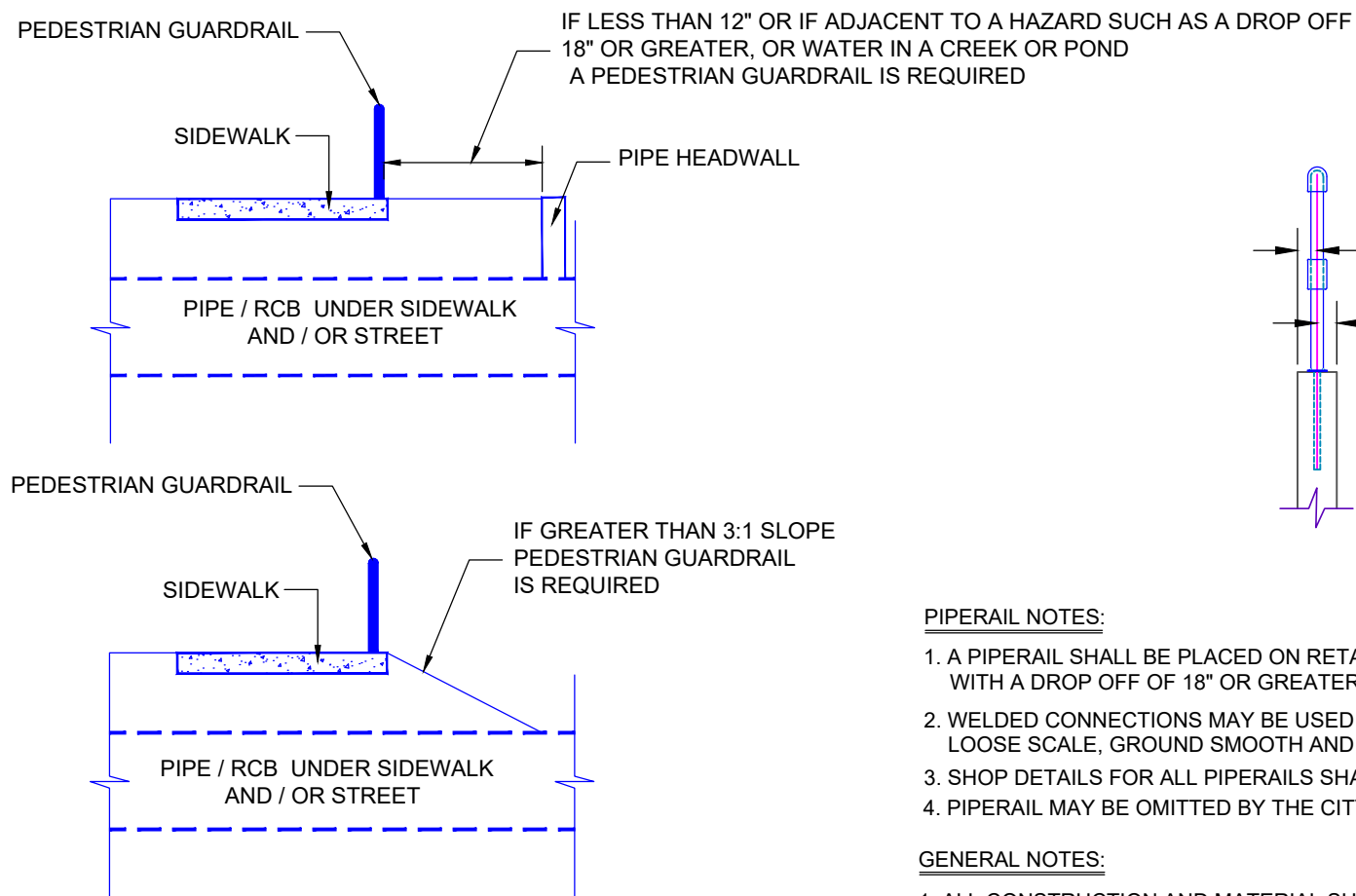
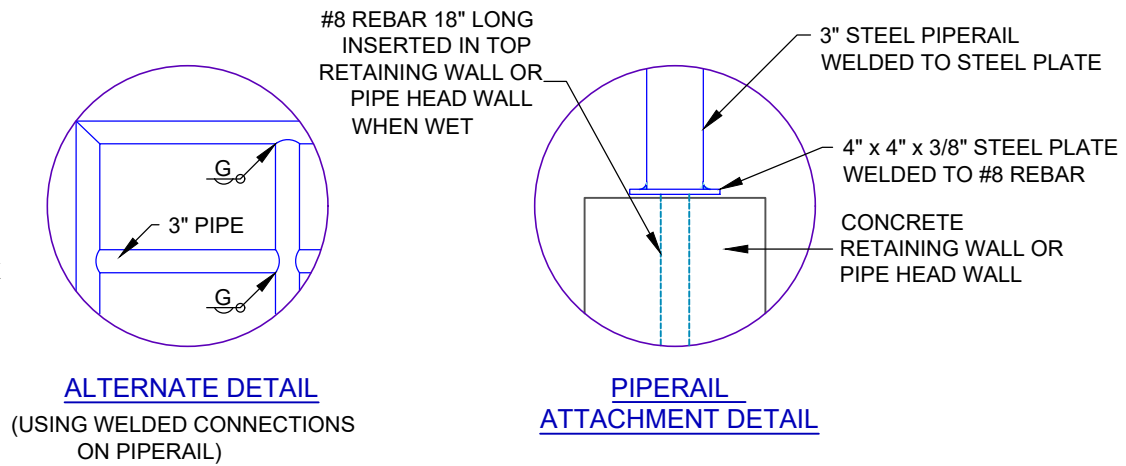
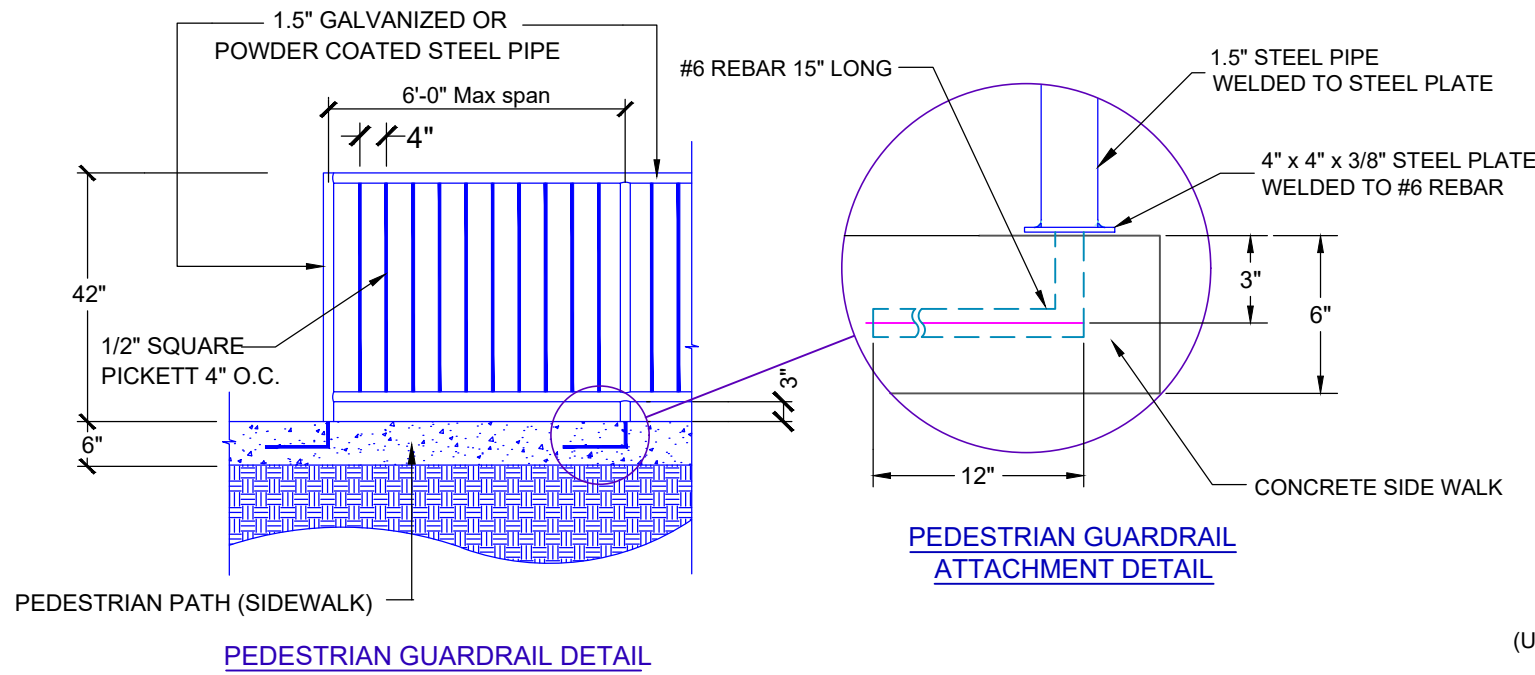

NOTES:

1. VERTICAL STEEL PIPE TO BE SET ON 6" CENTERS, 4" CLEAR FROM BACK EDGE OF SIDEWALK.
2. MATERIALS SHALL BE COMPLY WITH THE STD. SPECIFICATIONS. SUBMIT SHOP DRAWING FOR APPROVAL PRIOR TO FABRICATION.

PIPERAIL NOTES:

1. A PIPERAIL SHALL BE PLACED ON RETAINING WALLS AND PIPE HEADWALLS WITHIN PUBLIC ROW OR UTILITY / DRAINAGE EASEMENT WITH A DROP OFF OF 18" OR GREATER.
2. WELDED CONNECTIONS MAY BE USED FOR PIPERAILS. WELDED CONNECTIONS SHALL BE THOROUGHLY CLEANED OF ALL LOOSE SCALE, GROUND SMOOTH AND SPOT PAINTED WITH TWO COATS OF ZINC RICH PAINT.
3. SHOP DETAILS FOR ALL PIPERAILS SHALL BE SUBMITTED FOR APPROVAL.
4. PIPERAIL MAY BE OMITTED BY THE CITY ENGINEER.

GENERAL NOTES:

1. ALL CONSTRUCTION AND MATERIAL SHALL BE IN ACCORDANCE WITH THE OKLAHOMA CITY STANDARD SPECIFICATIONS
2. ALL EXPOSED CONCRETE EDGES SHALL HAVE A 3/4" CHAMFER.
3. ALL CONCRETE SHALL BE CLASS "A" CONCRETE 3000 PSI.
4. EXPANSION JOINTS SHALL BE AT A MAXIMUM OF 30'-0" INTERVALS.
5. ALL REINFORCING STEEL BARS SHALL BE DEFORMED BARS COLD BENT, NO WELDS PERMITTED.
6. ALL EXPOSED CONCRETE SURFACES SHALL HAVE A VERTICAL LIGHT BROOM FINISH.
7. ALL PEDESTRIAN GUARDRAIL AND PIPERAIL MATERIAL SHALL BE GALVANIZED OR POWDER COATED.

The City of
Oklahoma City
Public Works Department
Engineering Division

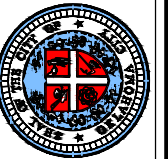

APPROVED BY:  DATE: 09-12-2023
ERIC J. WENGER, P.E.
CITY ENGINEER
DRAWN: TYN
DATE: 2-22-2023

**PEDESTRIAN GUARDRAIL AND
PIPERAIL DETAIL**

Drawing Number
D-505

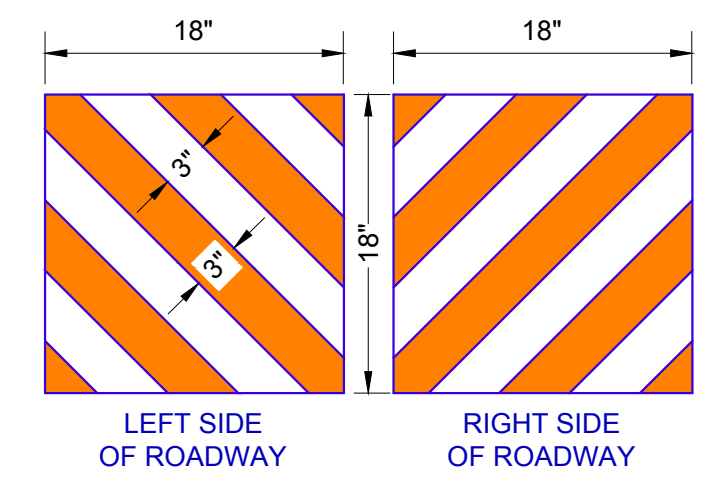
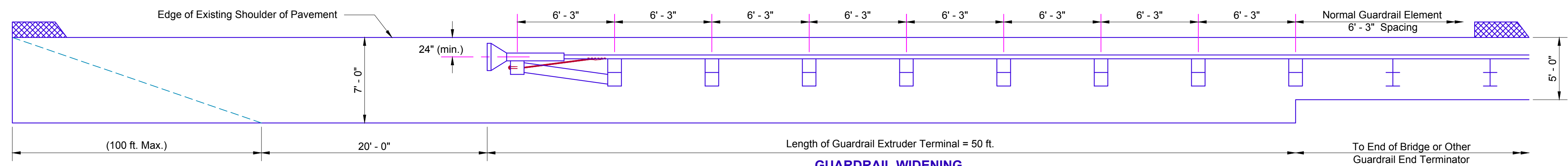

- DETAIL C REFLECTIVE MARKER**
1. Reflective marker should be attached to the 18" x 18" end of the G. E. T. prior to installation.
 2. Attachment surface should be thoroughly cleaned and dry before attaching marker. (Stick-on sheeling.)
 3. Attachment adhesive sheeting should be free of air bubbles with all edges free of air bubbles with all edges firmly bonded.

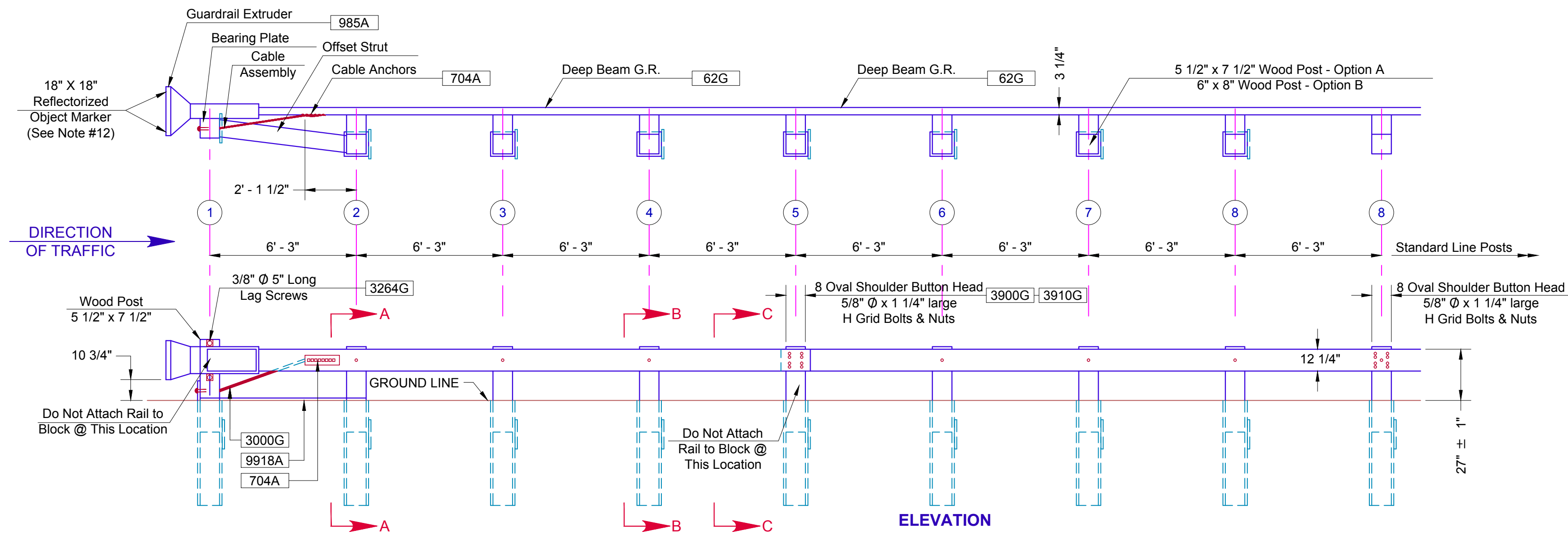

GENERAL NOTES

1. All construction and material requirements shall be in accordance with the Oklahoma Department of Transportation 1988 Standard Specifications and applicable Special Provisions covering Guardrail Extruder Terminal.
2. All bolts, nuts, cable anchors, groundline cables and bearing plates shall be galvanized in accordance with section 732 of the Standard Specifications for Highway Construction, 1988 edition.
3. Guardrail components shall meet the applicable standards of "A Guide to Standardized Highway Rail Hardware", prepared and approved by the AASHTO-ARTBA-AGC Joint Cooperative Committee, Technical Bulletin Number 2688.
4. The steel tubes shall not protrude more than 4" above the ground (measured along a 5 foot chord.) Site grading may be necessary to meet this requirement.
5. The steel tubes may be driven with an approved driving head. they shall not be driven with the wood post in the tube. If the steel tubes are placed in drilled holes, the backfill material must be compacted to insure no settlement of tube.
6. When rock excavation is encountered, a 12" diameter post hole, 20 inches deep, may be used if approved by the Engineer. Granular material will be placed in the bottom of the hole approximately 2 1/2" deep to provide drainage. The steel tube sleeves may be field cut to 20 inches in length, placed in the hole and backfilled with adequately compacted material excavated from the hole.
7. The breakaway cable assembly must be taut. A locking device, (vice grips or channel lock pliers) should be used to prevent the cable from twisting when tightening nuts.
8. The wood blockouts shall be "toe nailed" into the rectangular wood posts to prevent them from turning when the wood shrinks.
9. For curb installations, the soil tubes and posts shall be installed at the proper ground elevation behind the curb. The posts will then require pre holes to be field drilled to accommodate the 'rail to post' connection bolt to maintain the proper height of the rail above the gutter pan. The excess post length above the rail will be removed if directed by the Engineer.
10. When the guardrail extruder terminal is specified as the end treatment for the MBGF installation, the MBGF will be tapered at a rate of 50 to 1, over the 50 foot GET system, to prevent the extruder head from encroaching on the shoulder. The taper may be decreased or eliminated for specific installations if directed by the Engineer. A 25 to 1 taper rate will be used at curb sections, beginning at post number one (recommended for curb sections no greater than 4 inches in height.) See Details A & B.
11. Extruder type terminals shall be installed when adjacent driving lanes are within 25 feet (horizontally) of extension side on the extruder terminal.
12. Extruder approach end (18" x 18" face) shall be covered by a Type I Object Marker of simulated Type III Object Marker (adhesive reflector sheeting,) with cost to be included in the price of extruder terminal. See Detail C.
13. The 5/8 inch flat washer is used under the nut behind the post only. No washer is used at the rail.
14. The breakaway posts at locations #5, 6, 7 & 8 may be as shown in Option B without foundation tubes. Posts at locations #1, 2, 3 & 4 must use foundation tubes.
15. Wood posts are required with the guardrail extruder terminal (GET.)
16. For additional information on the widening typical section. See Standard GRAU-3 LATEST REVISION.

G. E. T. BILL OF MATERIALS			
Code #	OPTION		DESCRIPTION
	A	B	
62G	1	1	1 Deep Beam Guardrail (12 Ga.)
60G	1	1	2 Deep Beam Guardrail (12 Ga.)
740G	8	4	Steel Tube -- 6" x 8" x 54" x 3/16"
766G	8	4	Soil Plate -- 18" x 24" x 1/4"
4147B	8	4	Wood Posts -- 5 1/2" x 7 1/2" x 45"
4148B	7	7	Wood Block -- 5 1/2" x 6 1/2" x 14"
705G	1	1	Pipe Sleeve -- 2" standard pipe x 5 1/2"
782G	1	1	Bearing Plate -- 8" x 8" x 5/8"
704A	1	1	Cable Anchor
3000G	1	1	Cable Assembly
9918A	1	1	Offset Strut
985A	1	1	Guardrail Extruder
4063B	--	4	Wood Posts -- 6" x 8" x 72"
HARDWARE			
3478G	16	8	5/8" x 7 1/2" Hex Head Bolt (Soil Plates)
3497G	8	4	5/8" x 9 1/2" Hex Head Bolt (Top of tubes)
3300G	11	11	5/8" Washer (2 each at Tubes 1 & 2 + 7 Posts)
3580G	7	7	5/8" x 18" H. G. R. Post Blot (Posts 2 thru 8)
3360G	16	16	5/8" x 1 1/4" H. G. R. Splice Bolt
3340G	47	35	5/8" H.G.R. Nut (SPL --16. Tubes--12, GR--16)
3364G	2	2	3/8" x 5" Lag Screw
3910G	2	2	1" hex Nut (Anchor Cable)
3900G	2	2	1" Washer (Anchor Cable)
3117B	1	1	ReflectORIZED Object Marker (18" x 18")

BASIS OF PAYMENT		
ITEM #	ITEM	UNIT
623.06 (H)	G. E. T. GUARDRAIL END SECTIN	EACH

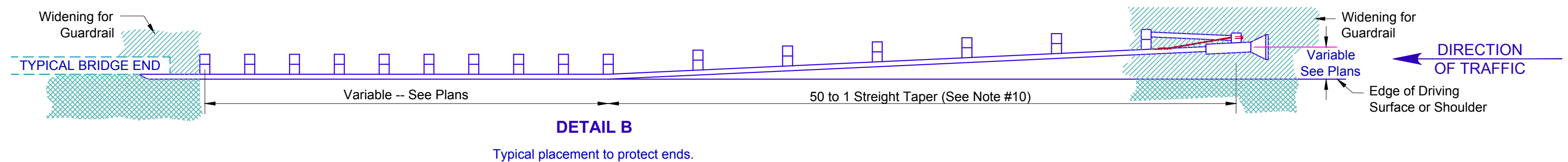
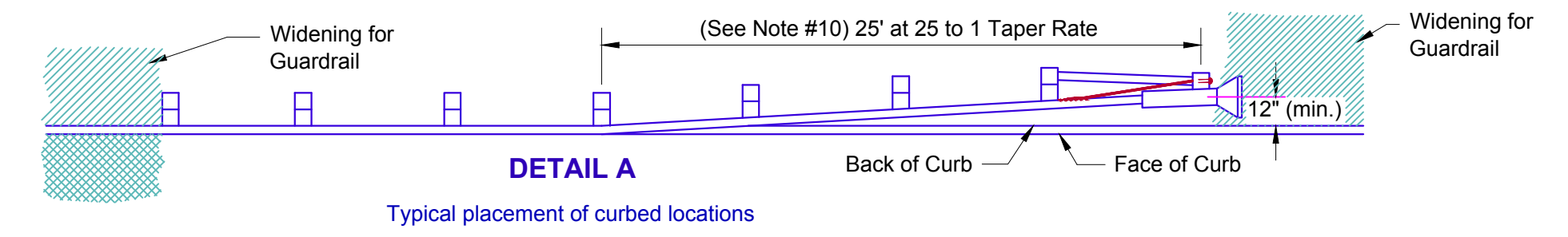
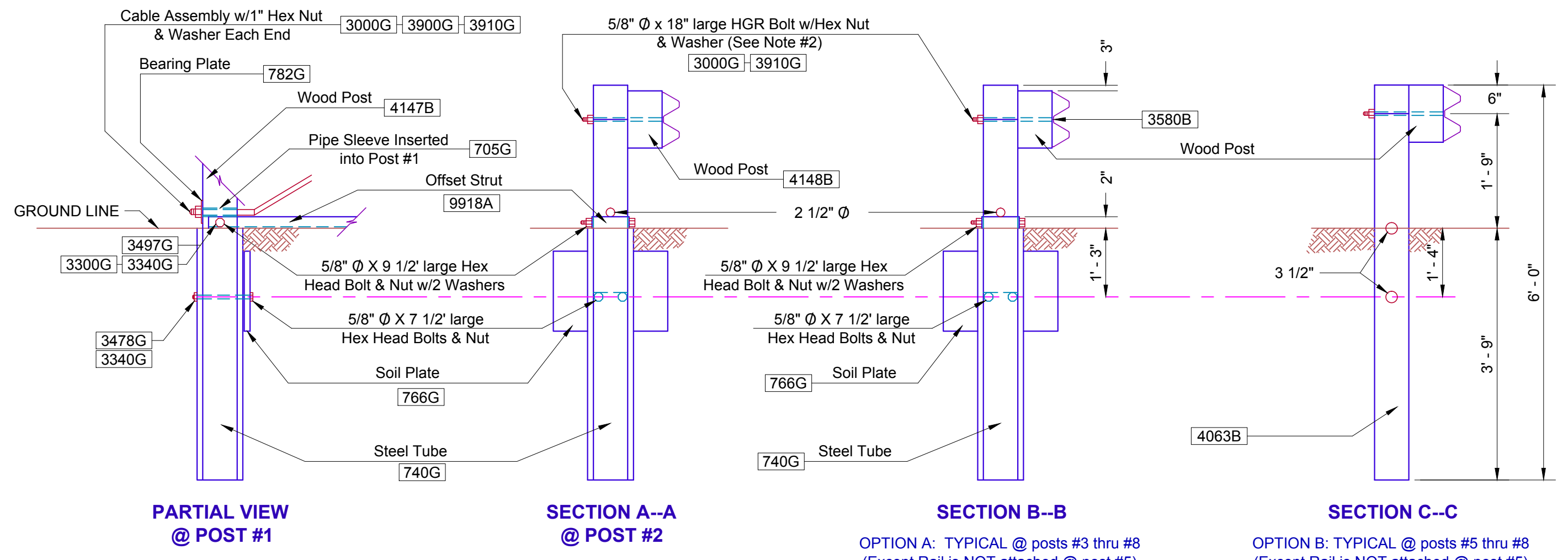

D:\okc.okc\PW-Section CITY.ACAD-STDs.D-600 VSC 02-07-13

The City of Oklahoma City Public Works Department Engineering Division

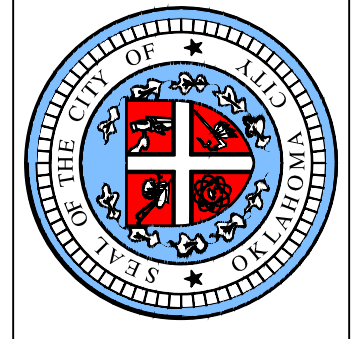

APPROVED BY: ERIC J. WENGER, P.E. CITY ENGINEER
DATE: 02-07-13
DRAWN: VSC
DATE: 02-07-13

GUARDRAIL EXTRUDER TERMINAL

Drawing Number D-600

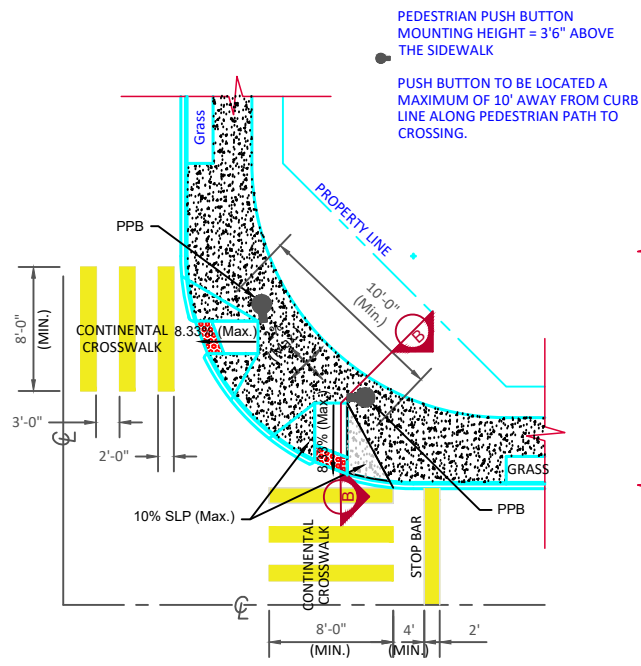

CURB RAMP TYPE "A"

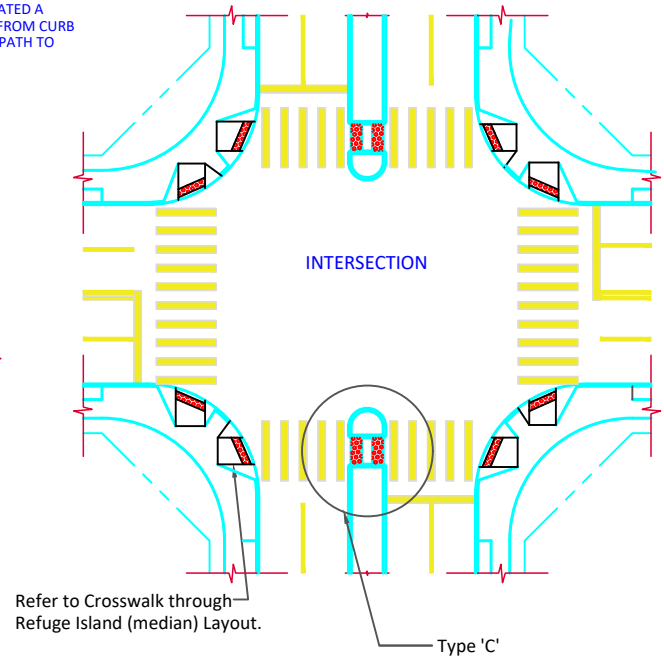

INTERSECTION WITH REFUGE ISLANDS LAYOUT

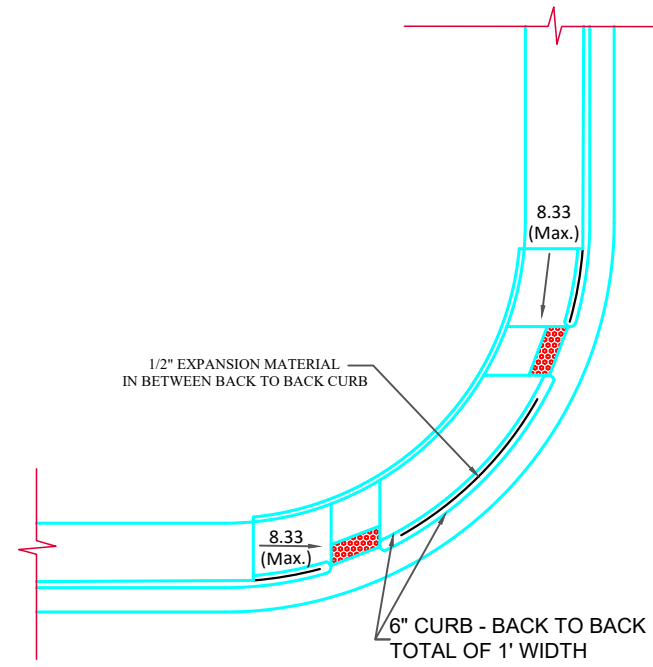

BACK OF CURB RAMP WITHOUT PEDESTRIAN PUSH BUTTON TYPE "G"

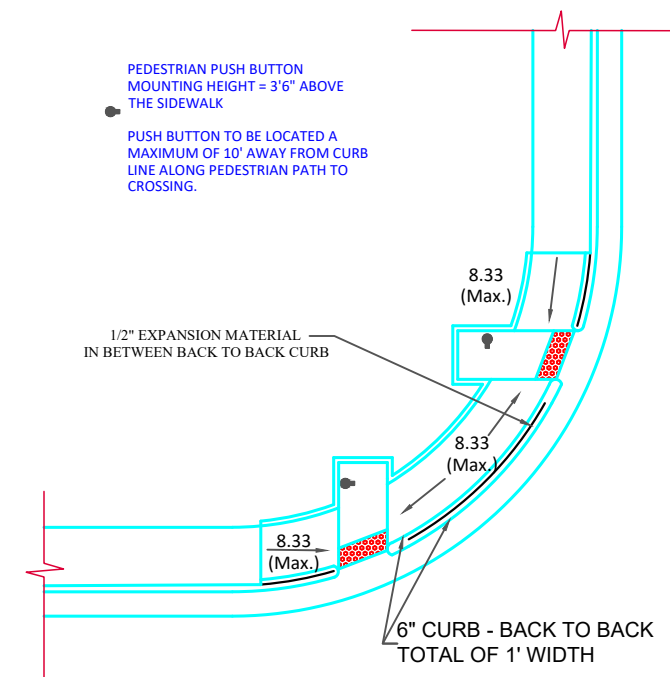

BACK OF CURB RAMP WITH PEDESTRIAN PUSH BUTTON TYPE "G"

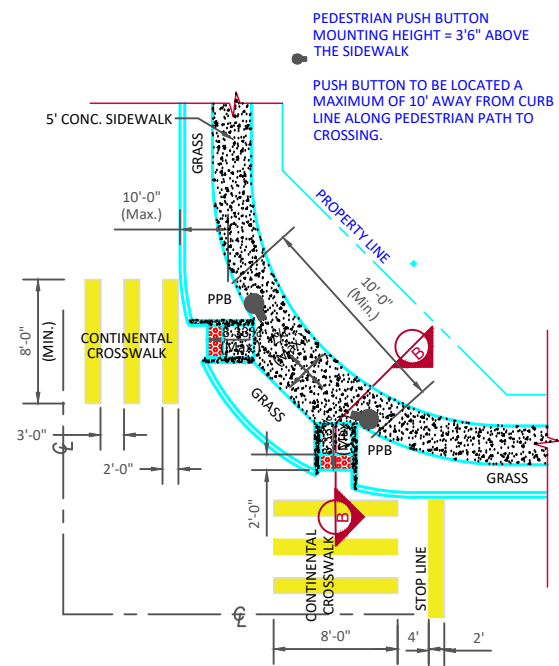

CURB RAMP TYPE "B"

See Detail 1 & Detail 2 (Sheet B)

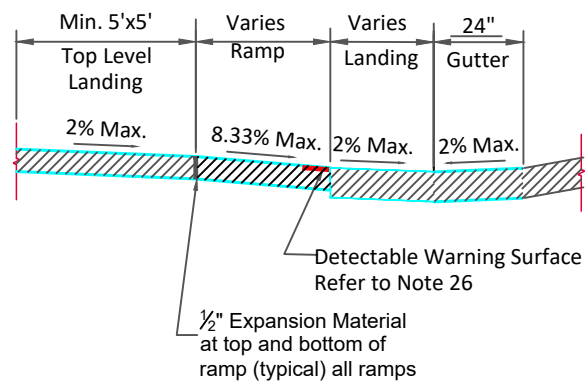

SECTION B-B

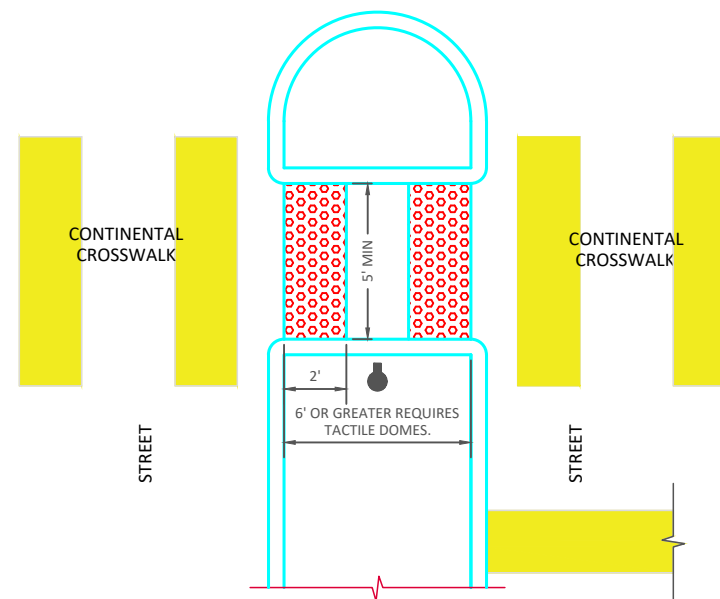

STANDARD CROSSWALK THROUGH MEDIAN LAYOUT TYPE "C"

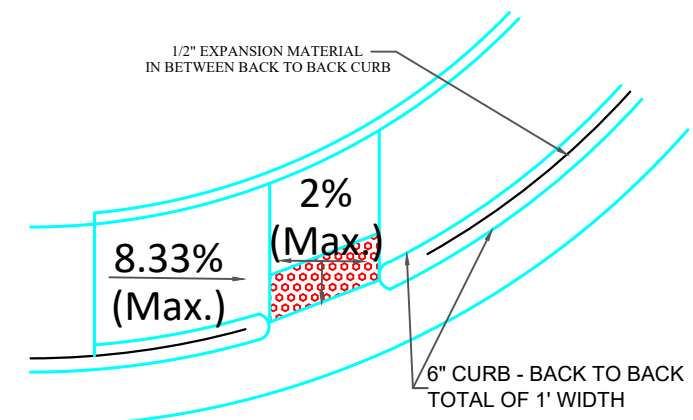

DETAIL OF TYPE "G" RAMP

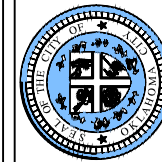

APPROVED BY: *Eric J. Wenger* DATE: 09/12/2023
ERIC J. WENGER, P.E. CITY ENGINEER
DRAWN: VSC
DATE:

Curb-Ramp shall be used on narrow sidewalk or at mid block locations when standard curb ramp lay-out is not feasible. The 6" curb shall be installed along the edge of the back of sidewalk.

● PEDESTRIAN PUSH BUTTON MOUNTING HEIGHT = 3'6" ABOVE THE SIDEWALK
 PUSH BUTTON TO BE LOCATED A MAXIMUM OF 10' AWAY FROM CURB LINE ALONG PEDESTRIAN PATH TO CROSSING.

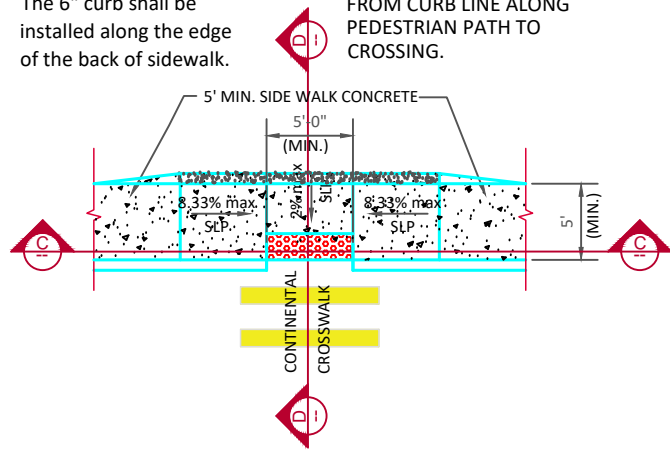

**PARALLEL CURB RAMP
TYPE "D"**

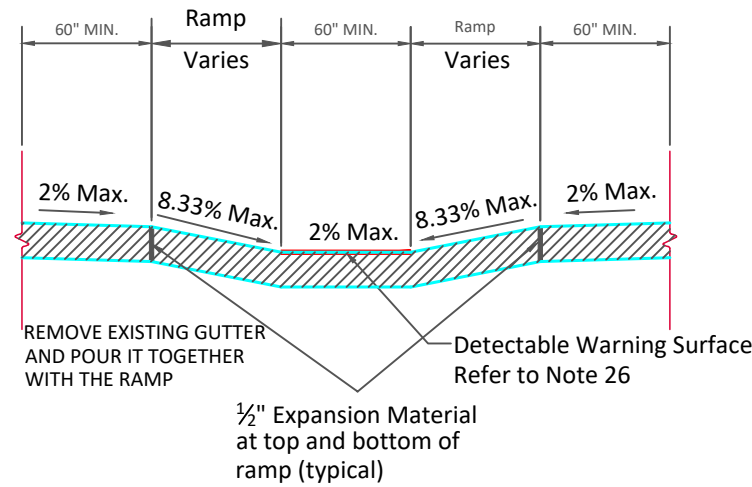

SECTION C-C

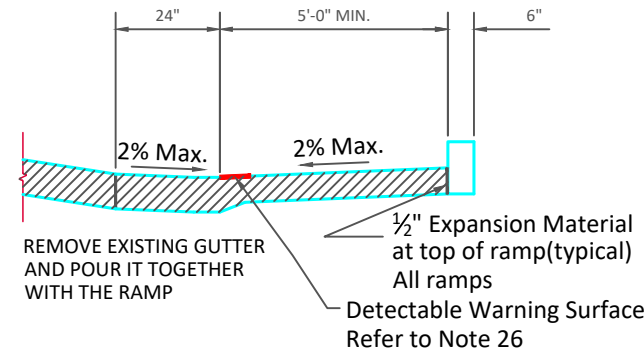

SECTION D-D

See Detail 2 for Isometric View

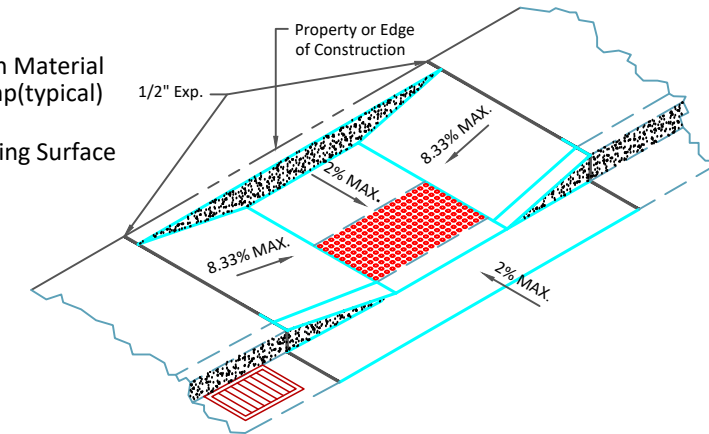

DETAIL 2 TYPE D

Isometric

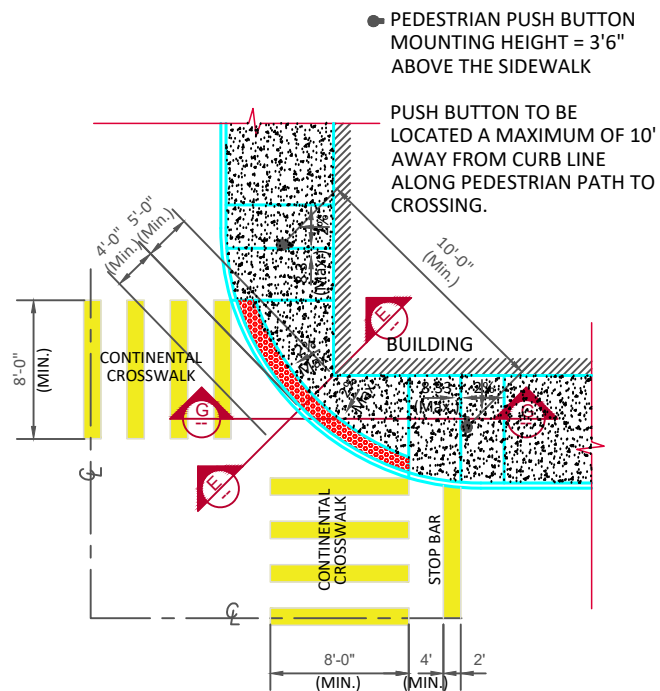

**RADIUS CURB RAMP
TYPE "E"**

See Detail 3 for Isometric View

Written approval by the City Engineer is required.

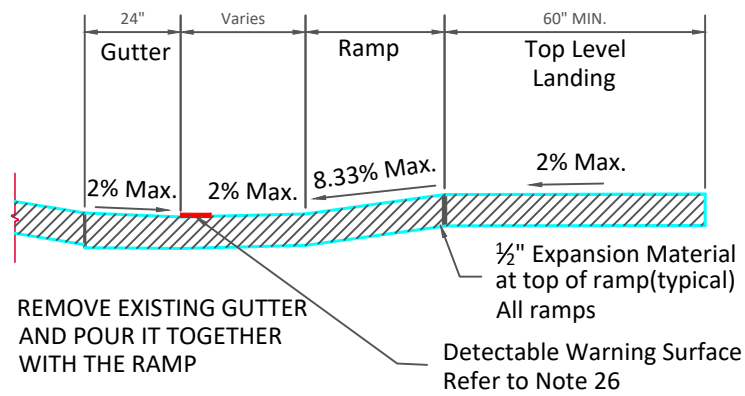

**SECTION G-G
TYPE "E"**

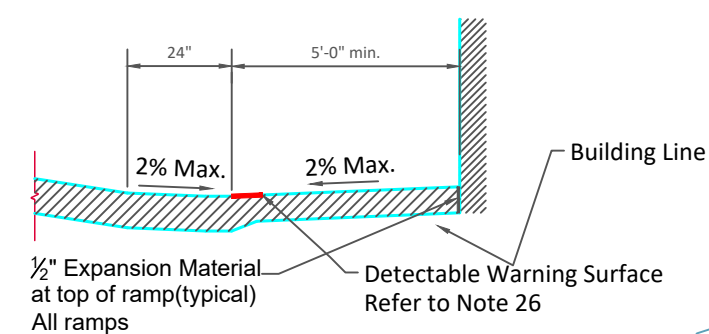

**SECTION E-E
TYPE "E"**

See Detail 3 for Isometric View

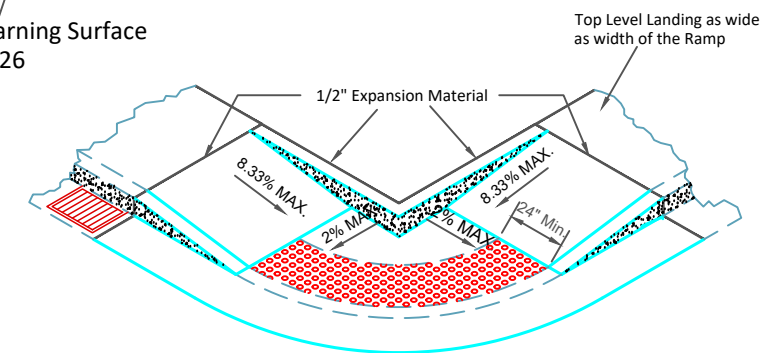

DETAIL 3 TYPE E

Isometric

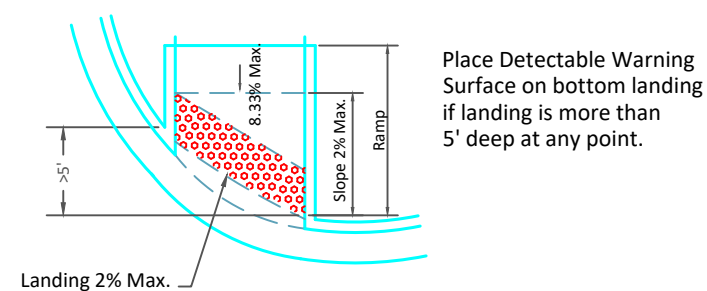

DETAIL 1

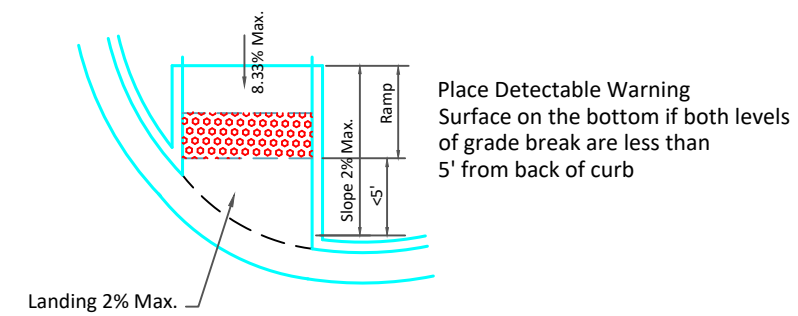

DETAIL 2

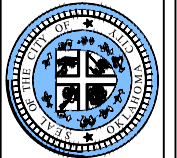

APPROVED BY:	DATE:
ERIC J. WENGER, P.E. CITY ENGINEER	09/12/2023
DRAWN:	VSC
DATE:	

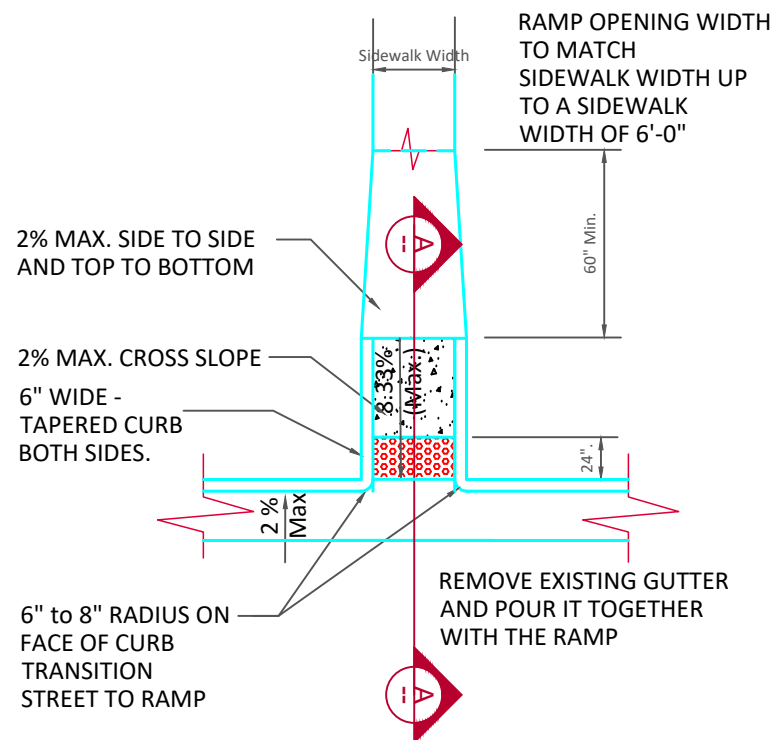

METHOD OF TRANSITIONING A RAMP WITH DIE OUT CURBS

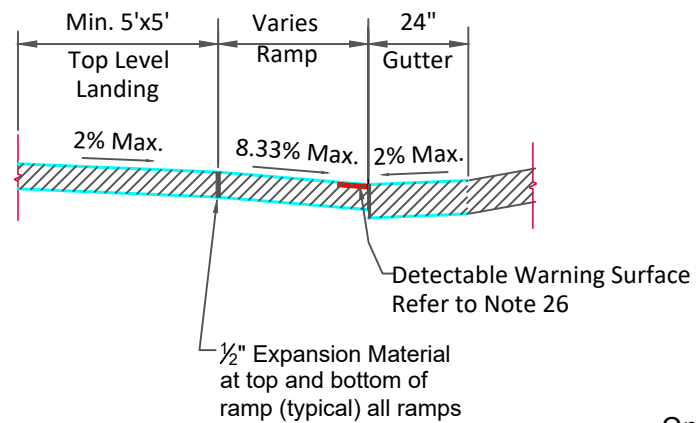

SECTION A-A

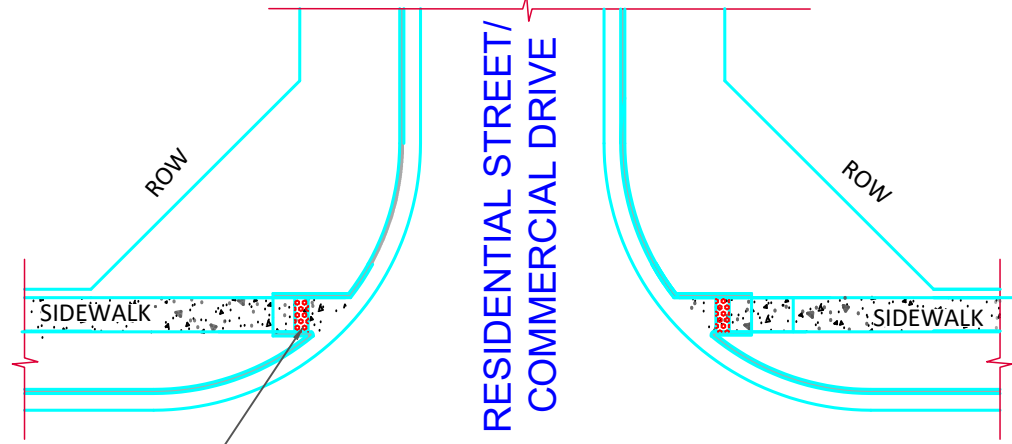

ARTERIAL / MINOR STREET RAMPS (OR COMMERCIAL DRIVES)

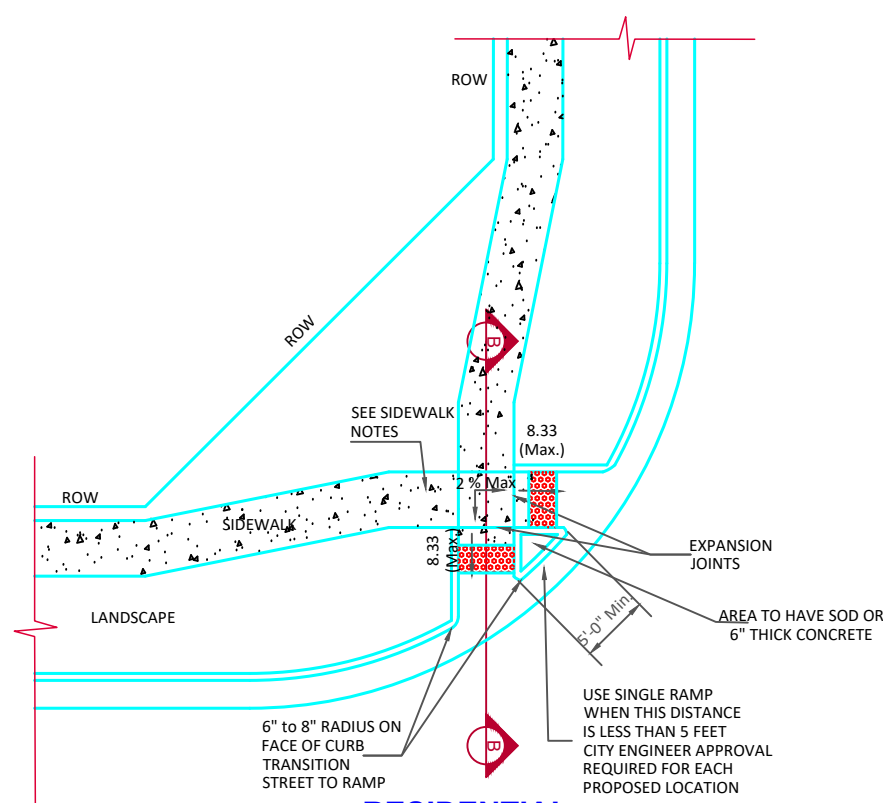

RESIDENTIAL CURB RAMP TYPE "F"

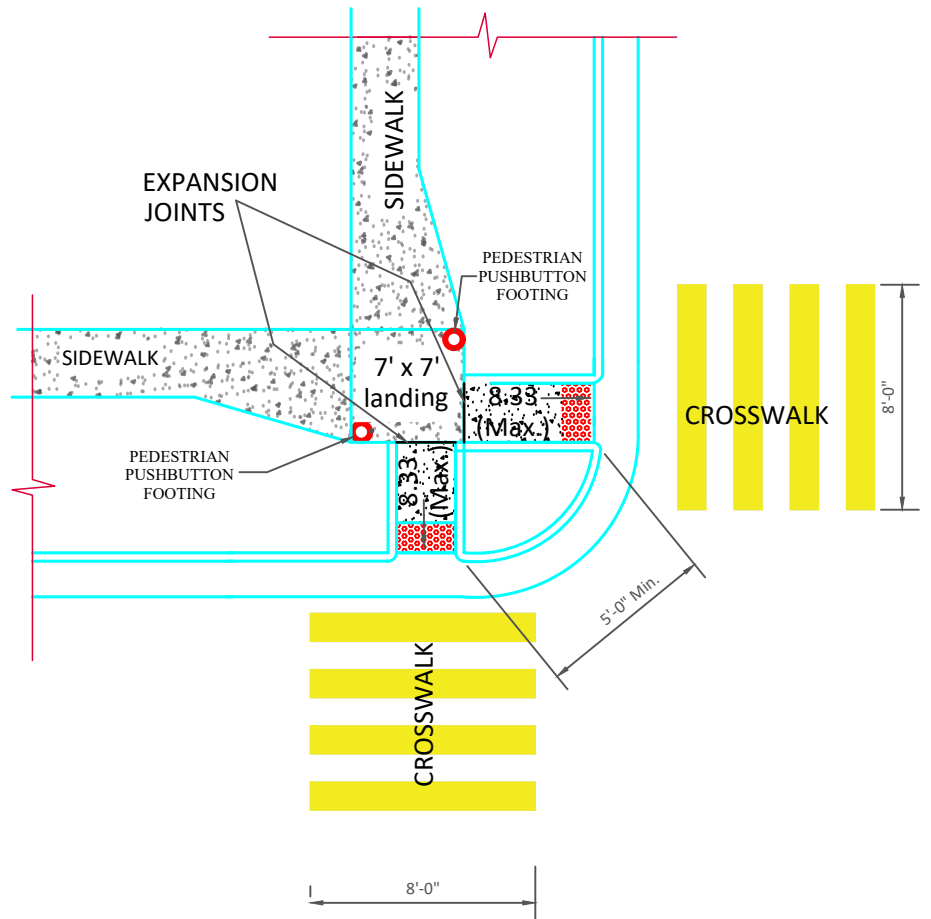

SHARED LANDING AT SIGNALIZED INTERSECTIONS

DETAIL 1

Detectable Warning Surface Specifications:

- Must provide a Visual Contrast.
- Raised Tactile surfaces used for way finding.
- Detectable Warning Surface shall be installed in a manner such that the domes are parallel to the direction of pedestrian travel.
- Install the Detectable Warning Surface beginning at back of curb.

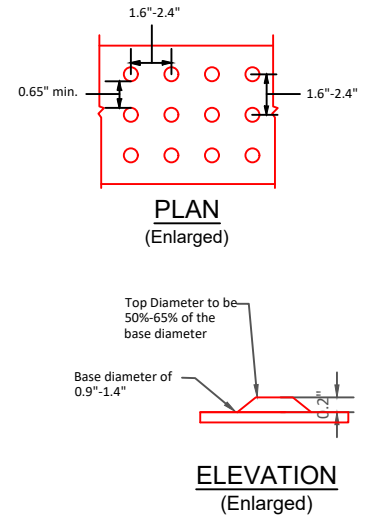

DETECTABLE WARNING SURFACE PATTERN LAYOUT

The City of
Oklahoma City
Public Works Department
Engineering Division

APPROVED BY:	DATE:	09/12/2023
ERIC J. WENGER, P.E. CITY ENGINEER		
DRAWN:	VSC	
DATE:		

**ADA CURB RAMP DETAILS
RESIDENTIAL STREETS
COMMERCIAL DRIVES**

Sidewalk Notes:

1. All work must meet current Americans with Disabilities Act (ADA) requirements.
2. Minimum sidewalk width shall be as follows: residential, 5'-0" at curb, 4'-0" at property line; commercial, 6'-0" at curb, 5'-0" at property line.
3. Sidewalk cross slope shall be a maximum of 2% and a minimum of 1/2% cross slope.
4. Whenever the width of the sidewalk is less than 5'-0", a 5' x 5' passing area with a maximum 2% slope and minimum 1/2% slope in any direction at intervals of 200' shall be installed.
5. Whenever changing direction in a sidewalk, install a 5' x 5' passing area with maximum 2% slope and minimum 1/2% slope in any direction.
6. Objects such as tree branches, signs, water fountains, etc. shall not protrude into the sidewalk more than 4" at the heights between 27" and 80".
7. Sidewalk shall be constructed of 4" thick concrete with medium broom finish on top of 2" of 1.5" crusher run, 3/8" rock screenings, 1.5" clean recycled concrete or approved equal. Developers of Residential Neighborhoods are allowed the usage of 2" of sand instead of the required crusher run.
8. All obstructions into the walk, such as power poles, hydrants, sign posts, etc. must have at least 48" of clear travel space around the obstruction.
9. Sidewalk running grade shall not exceed 5% unless the sidewalk is contained in the R-O-W and then cannot exceed the general grade established for the adjacent street.

General Notes:

10. Any deviation from the standard curb-ramp plans shall be approved by the City Engineer or his designee on a case by case basis.
11. The standard curb-ramp drawings supersede all previous drawings and shall be a part of the new curb ramp standard drawings.
12. All alternate ramps shall be approved by the City Engineer or his designee prior to construction.
13. Seal all sawed joints on sidewalks, landings and ramps. Width of expansion joint shall be 1/2"

Pedestrian Signals Notes:

14. Push button must be located adjacent to and accessible from a landing.
15. A clear space of 30" x 48" minimum dimension must be next to the push button.
16. Maximum reach to a push button can not exceed 10".

Curb Ramp Notes:

17. A curb ramp is defined as the entire concrete surface which includes the ramp and flared sides. The minimum 4' wide center portion, including the Detectable Warning Surface, shall have a sloped plane of 8.33% (1:12) maximum, and cross slope, not to exceed 2%. The "flared side" of the ramp shall lie on a slope of 10% (1:10) maximum measured along the curb. The curb ramp shall have a surface tolerance of 1/4" per 10 foot straight edge maximum.
18. The ramp center line and path of travel should be parallel to the sidewalk whenever possible. The full width of the ramp shall lie within the crosswalk area. It is desirable that the location of the ramp be as close as possible to the center of the crosswalk.
19. Curb Ramps shall not exceed 15' in length unless otherwise directed by the City Engineer.
20. Existing utility boxes and covers shall be adjusted flush with the curb ramp surface and shall not straddle any change in plane or material. Existing utility box frames and covers shall have matching surface finish on the entire frame and cover. New utility boxes shall not be placed within the accessible pathway.
21. The surface of the curb ramp and Detectable Warning Surface material shall be stable, firm and slip resistant. The concrete curb ramp surface shall be medium broom finished transverse to the axis of the ramp and shall be slightly rougher than the finish of the adjacent sidewalk surface.
22. A level landing 5'-0" deep, with a 2% maximum slope in each direction shall be provided at the upper end of each curb ramp to allow safe egress from the ramp surfaces. The width of the level landing shall be at least as wide as the width of the ramp. A clear space of a minimum of 30" wide x 48" deep shall be provided at pedestrian push buttons at signalized crossings. This space may be contained in the landing.
23. Existing vertical utility poles or street light poles may be incorporated into the flared sides, if necessary. The vertical obstruction shall be a minimum of 6" away from edge of the ramp. Pedestrian crosswalks push button poles, fire department call boxes and other poles with activated devices, may not be placed in the curb-ramp at any time. No new vertical obstructions may be located in the curb ramp or the accessible pathway.
24. Ramp opening shall be the same width as the sidewalk up to 6'-0" wide.
25. Curb Ramp shall be constructed with 8" thick concrete at collector and arterial streets; and with 6" thick concrete at residential streets. All on top of 2" of 1.5" crusher run, 3/8" rock screenings, 1.5" recycled concrete or approved equal. The 6" thick concrete will extend the maximum length of 6' from the face of curb and the 8" thick concrete will extend the maximum length of 8' from the face of curb. The remainder of the ramp will be constructed of 4" thick concrete and paid as sidewalk. All landings and incidental connections will be paid as sidewalk and will be constructed of 4" thick concrete. A 6" concrete curb will be constructed on each side of the ramp where 1:10 concrete slopes are not used.
26. For new construction all Detectable Warning Surfaces are to be set in concrete. Surface applied domes require special written approval by the City Engineer.
27. Curb ramp pay items shall only be used at street intersections, signalized driveways or alleys with tactile domes.
28. Where feasible, ramps shall align in such a way that the pedestrian travel path shall provide a direct path to corresponding ramp. Ramps that require pedestrians to change direction of travel in the street or driveway shall require City Engineer approval.
29. Where a ramp ties into an existing curb and gutter, the entire curb and gutter shall be removed and replaced extending 2 feet past the width of the ramp on each side.

The City of
Oklahoma City
Public Works Department
Engineering Division

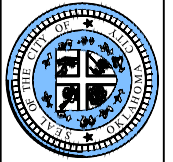

APPROVED BY:  DATE: 09/12/2023
ERIC J. WENGER, P.E.
CITY ENGINEER
DRAWN: VSC
DATE:

ADA CURB RAMP DETAILS

Drawing Number
D-700

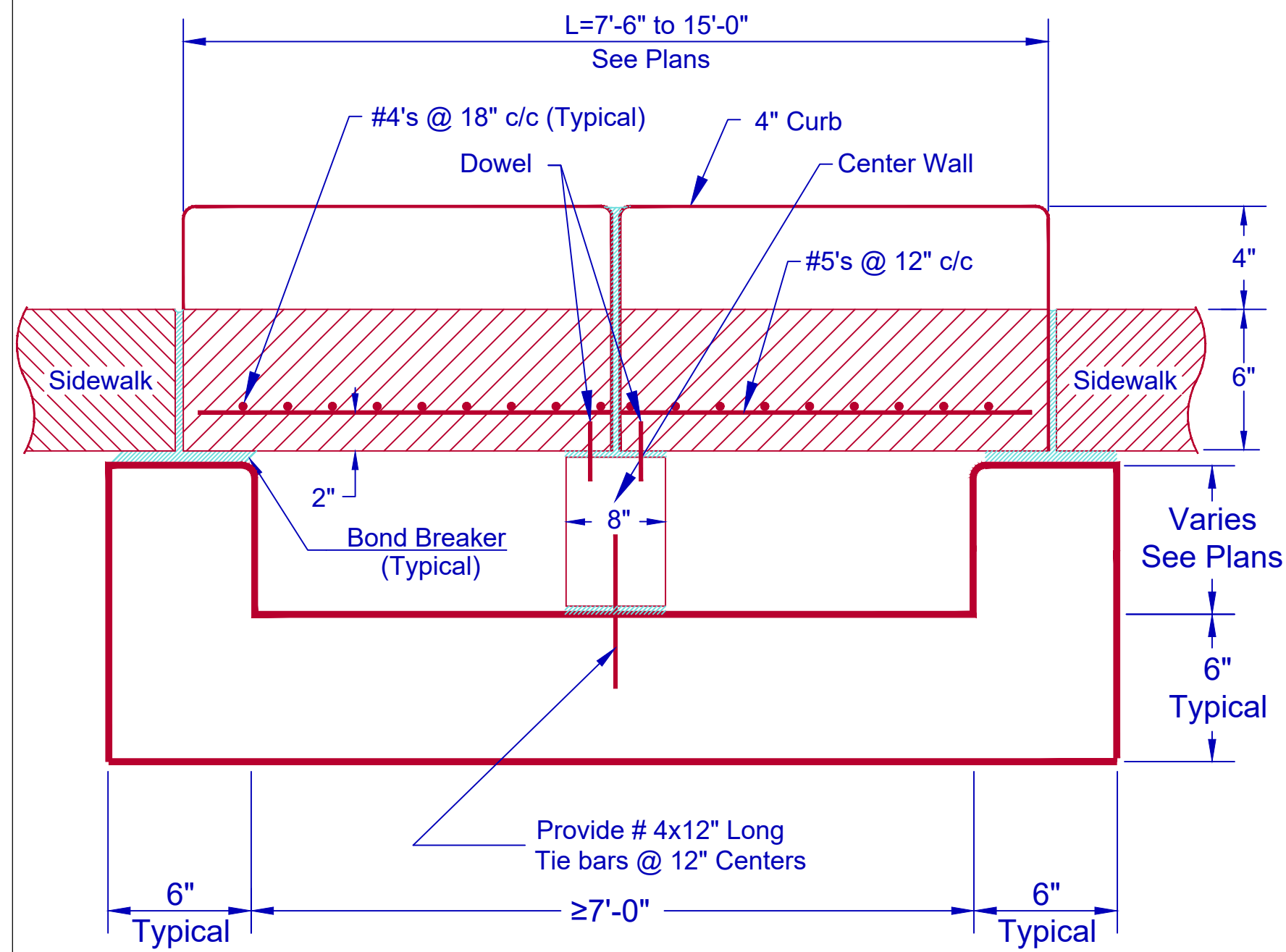

Section A-A for 7'-0" or greater span length

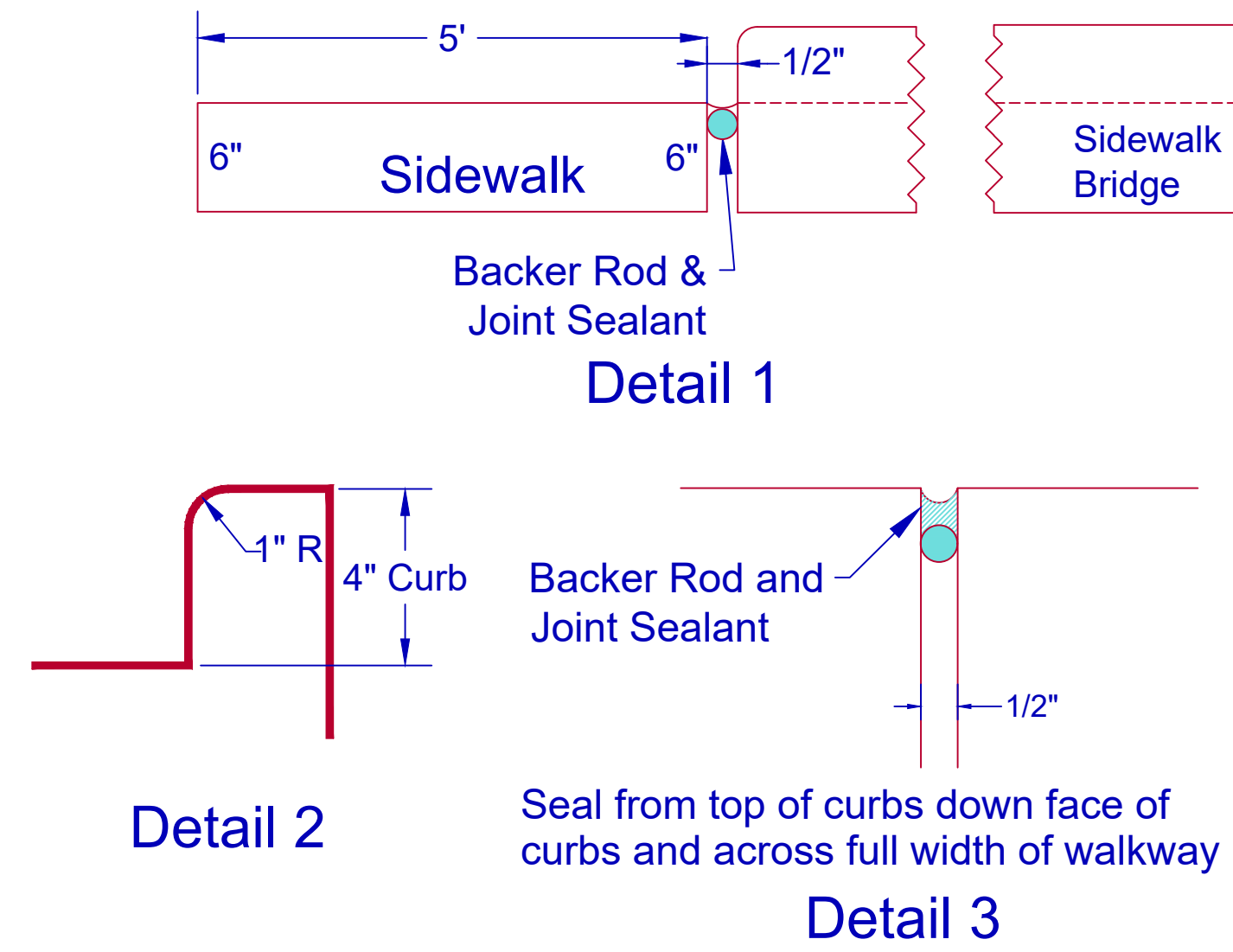

Sidewalk Bridge Notes:

1. The width of the sidewalk bridge must be at least as wide as the adjacent sidewalk.
2. # 5 bars must extend to within 1 1/2" of the end forms.
3. Flume crossing with sidewalk bridges having a walking path greater than 5' wide require a separate design
4. Flume crossing with a dimension of 18" or greater from flume surface to the walkway surface will require pedestrian guardrail.
5. 3/4" chamfer (typical) required on all exposed edges.

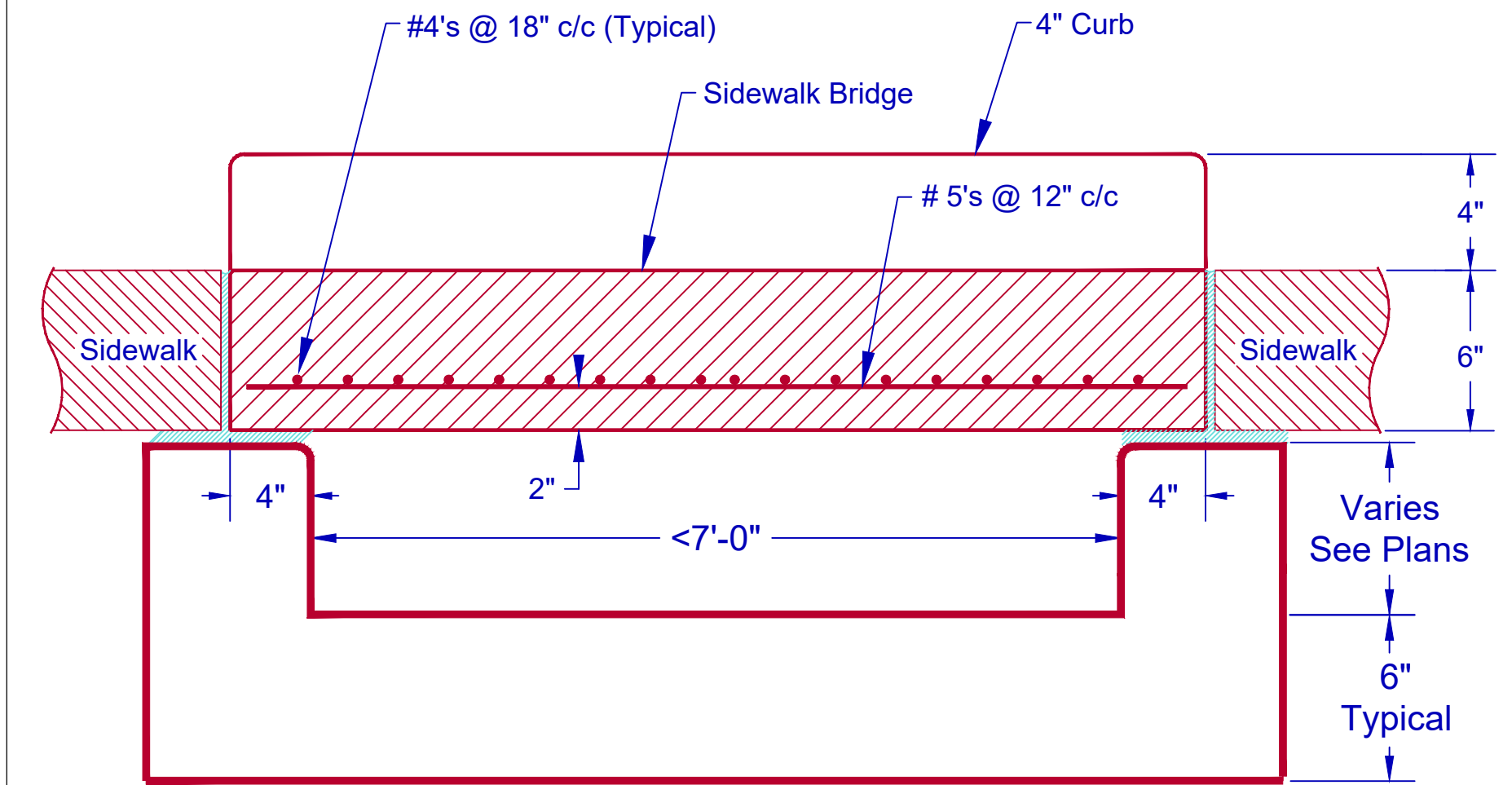

Section A-A for less 7'-0" span length

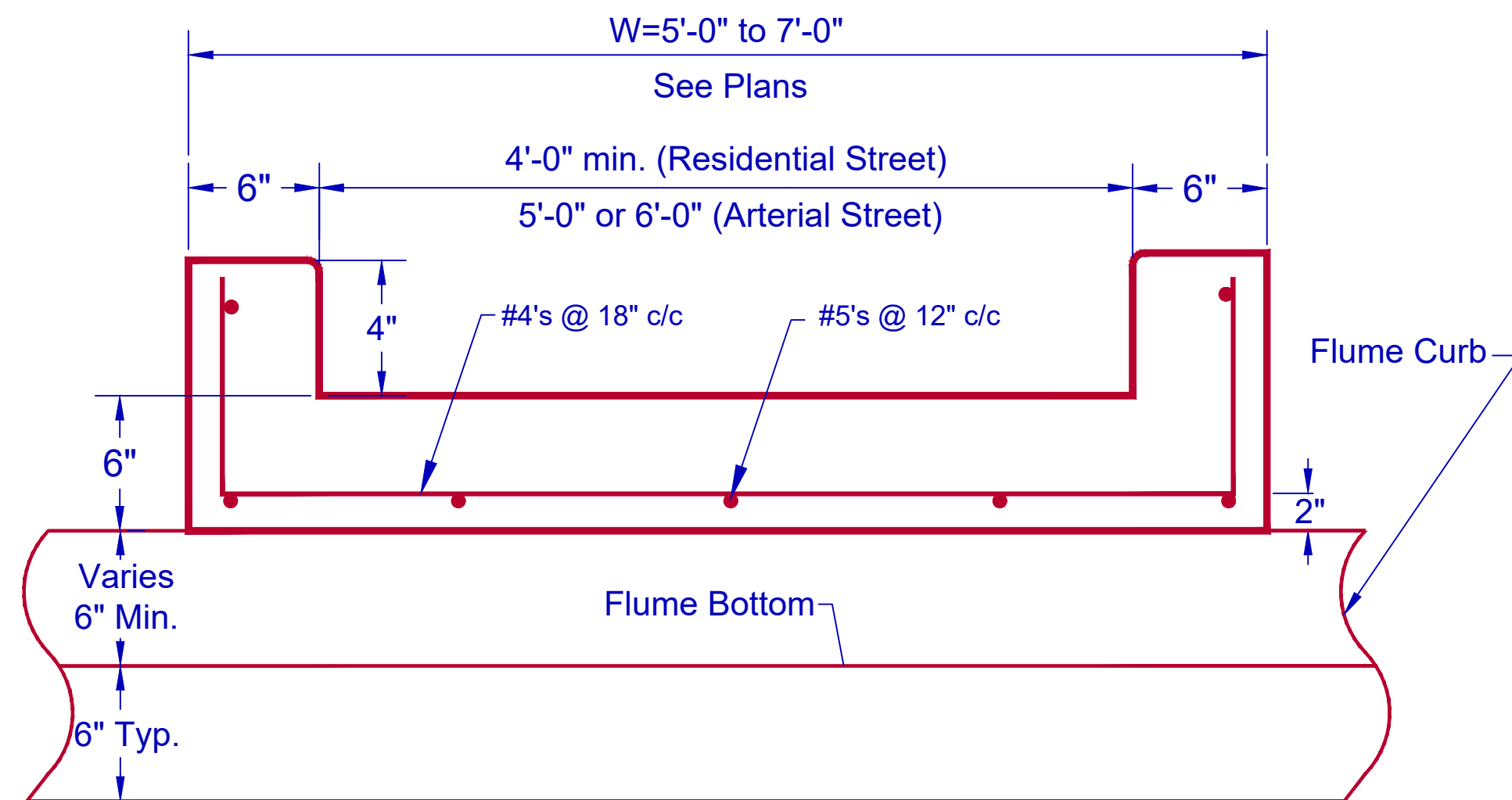

Section B-B

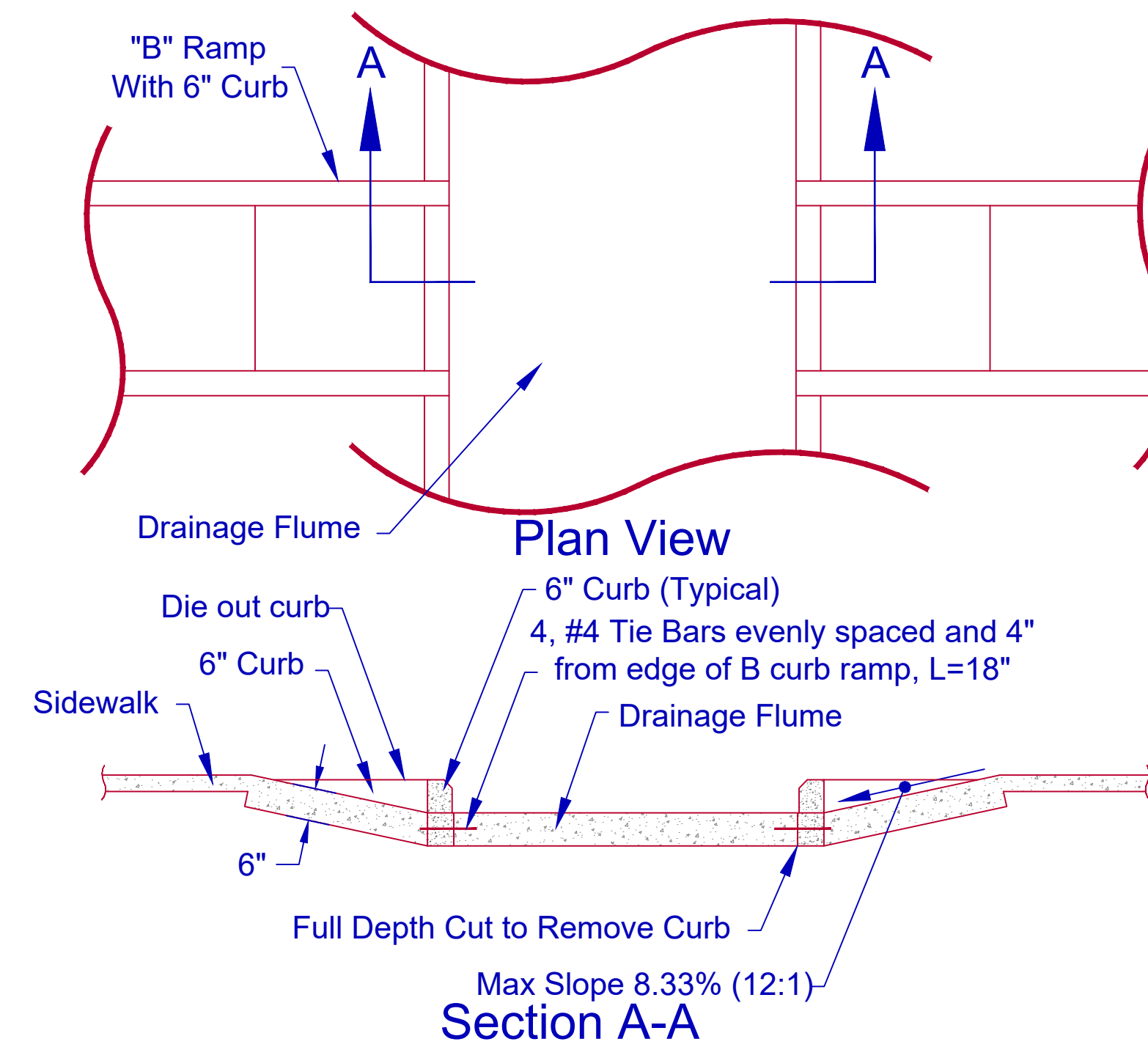

RAMP NOTES:

1. In most cases, to be constructed as shown above unless grade or other factors require the construction of a sidewalk bridge.
2. If flume grade is more than 2%, then bottom of flume must be reconstructed so the longitudinal grade is 2% or less to meet ADA requirements for sidewalk cross slope. The transition on each side of sidewalk in bottom of flume must be at least 2' wide and a maximum grade equal to 2x the longitudinal flume grade.

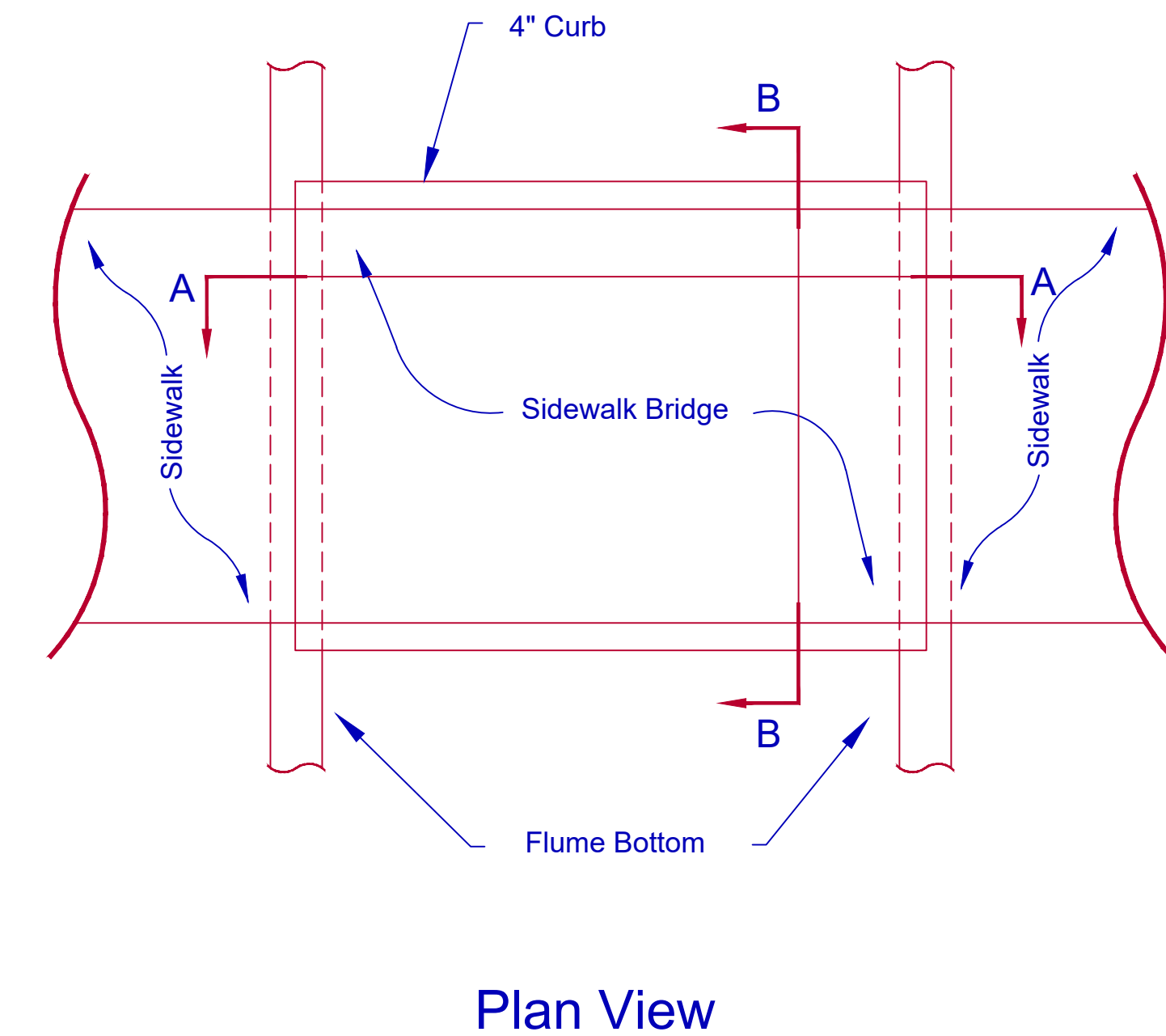

Sidewalk at Flume Crossing

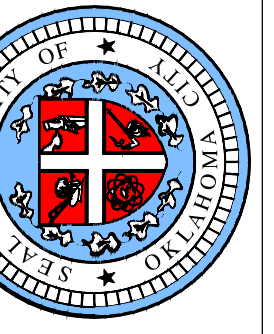

APPROVED BY: DATE: 09/12/2023
ERIC J. WENGER, P.E.
CITY ENGINEER

DRAWN: TVN
DATE: 02-26-20

**ADA SIDEWALK AND CURB RAMP
AT FLUME DETAILS**

Drawing Number
D-700E

PAVEMENT REPAIR DETAILS

HOT MIX ASPHALT (HMA) OVERLAY

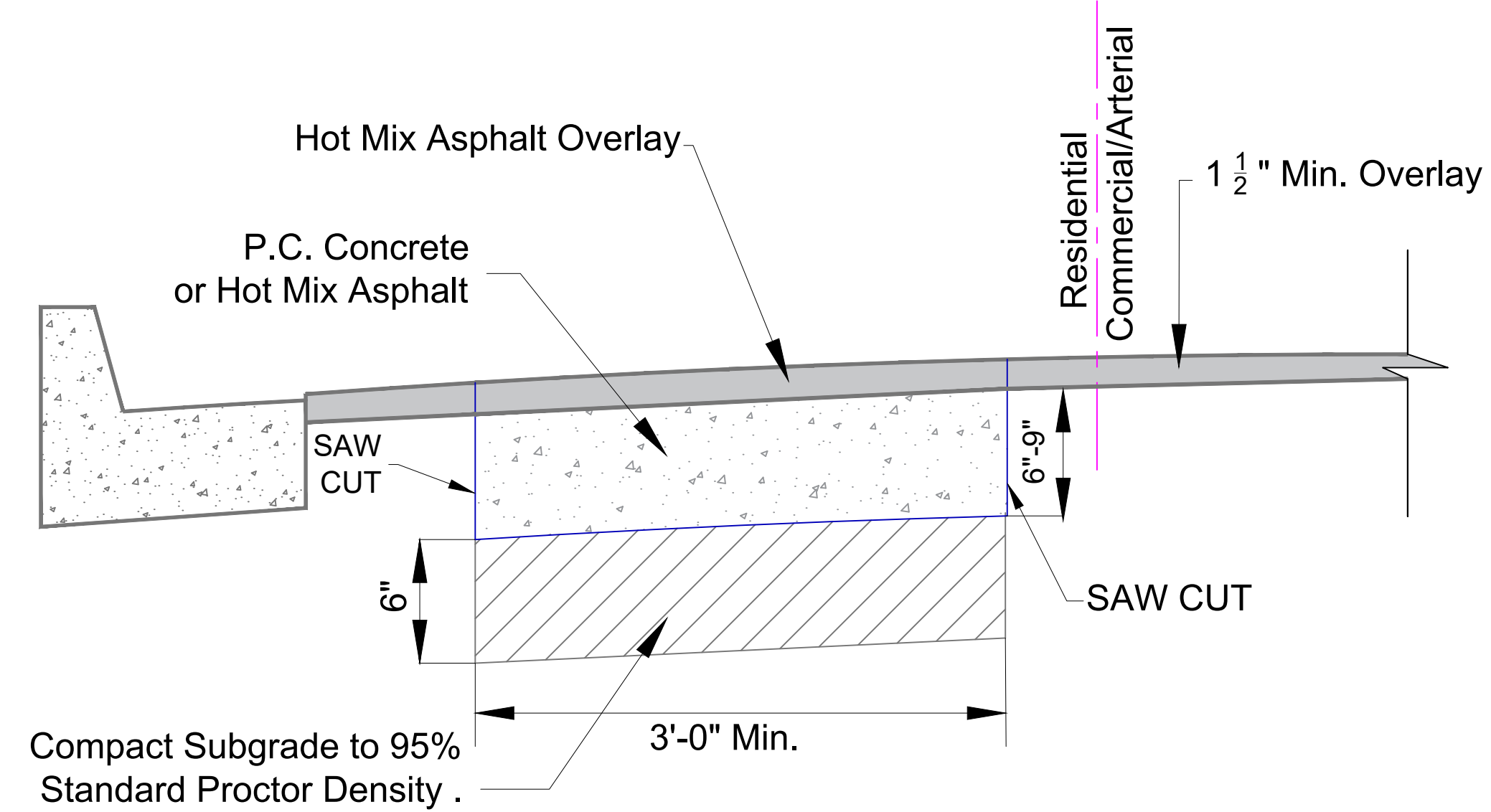

NOTES:

1. Pavement repairs includes removal of Asphalt or P.C. Concrete Pavement depending on existing conditions, saw cut should be included in price.
2. Hot Mix Asphalt shall meet density-specification

EXISTING ASPHALT OR CONCRETE BASE REPAIR DETAIL

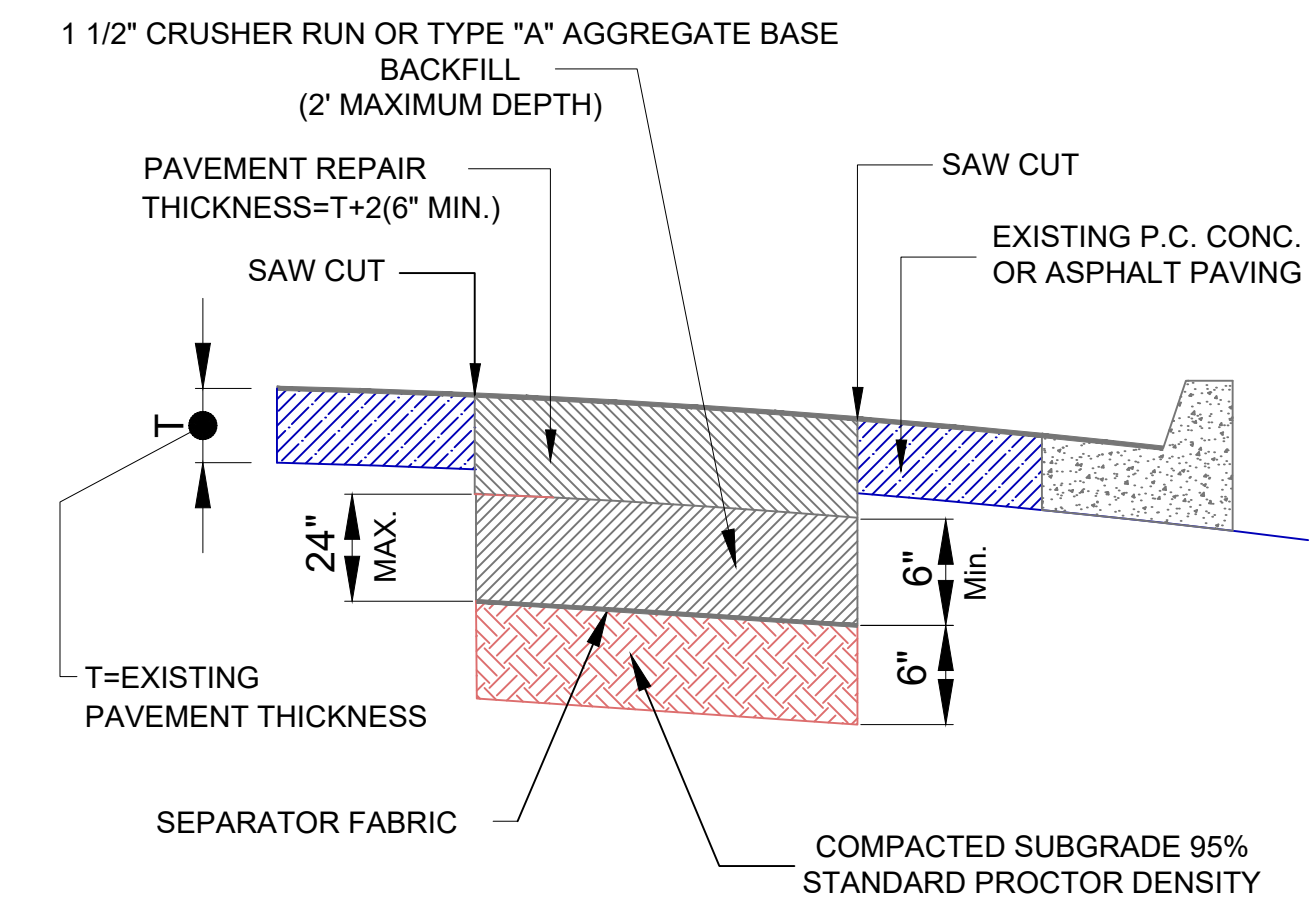

NOTES:

1. Excavation and aggregate base backfill begins at the bottom of the existing pavement and extends downward to a maximum depth of 2 feet.
2. The contractor shall not begin the backfill operation until measurement of the excavation has been made and agreed upon by the engineer and the contractor.
3. Backfill material will be placed in lifts not to exceed six inches (6") and compacted to 95% Standard Proctor Density.
4. Subgrade compaction saw cut and separator fabric will not be paid for separately. Include cost in price bid for other items of work.

PAVEMENT REPAIR DETAILS

P.C. CONCRETE PAVING

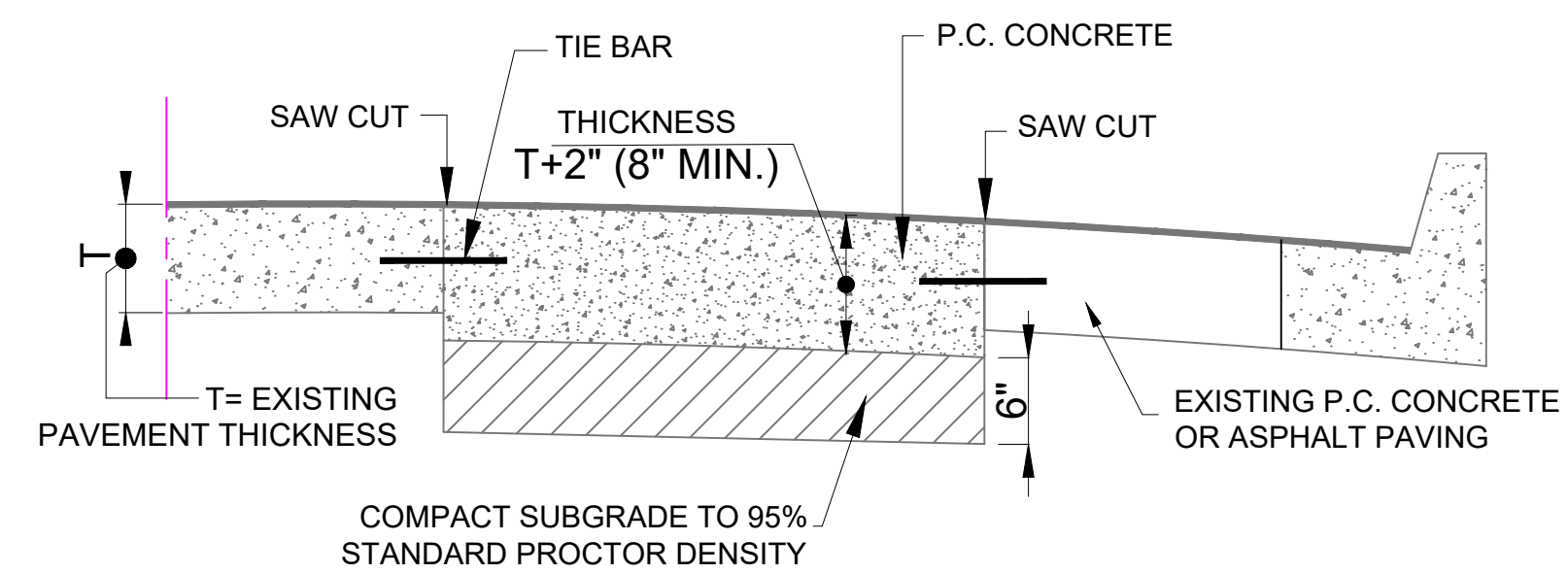

NOTES:

1. Remove existing concrete paving, to be included in price. Partial panel replacement not permitted, saw cut should be included in price.
2. When utility trench is the reason for pavement repair, see typical permanent repair section for details on reinforcing steel, backfill material. and trench width, etc.
3. Tie bars to be 1" dia. deformed bars, 18" length and spaced at 18" centers. Anchored with epoxy.
4. For Transverse joints, use smooth bars with same dimensions as in note #3. Only One end anchored with epoxy
5. Concrete panel to be double sawed 6" apart to protect the pavement edge during excavation.

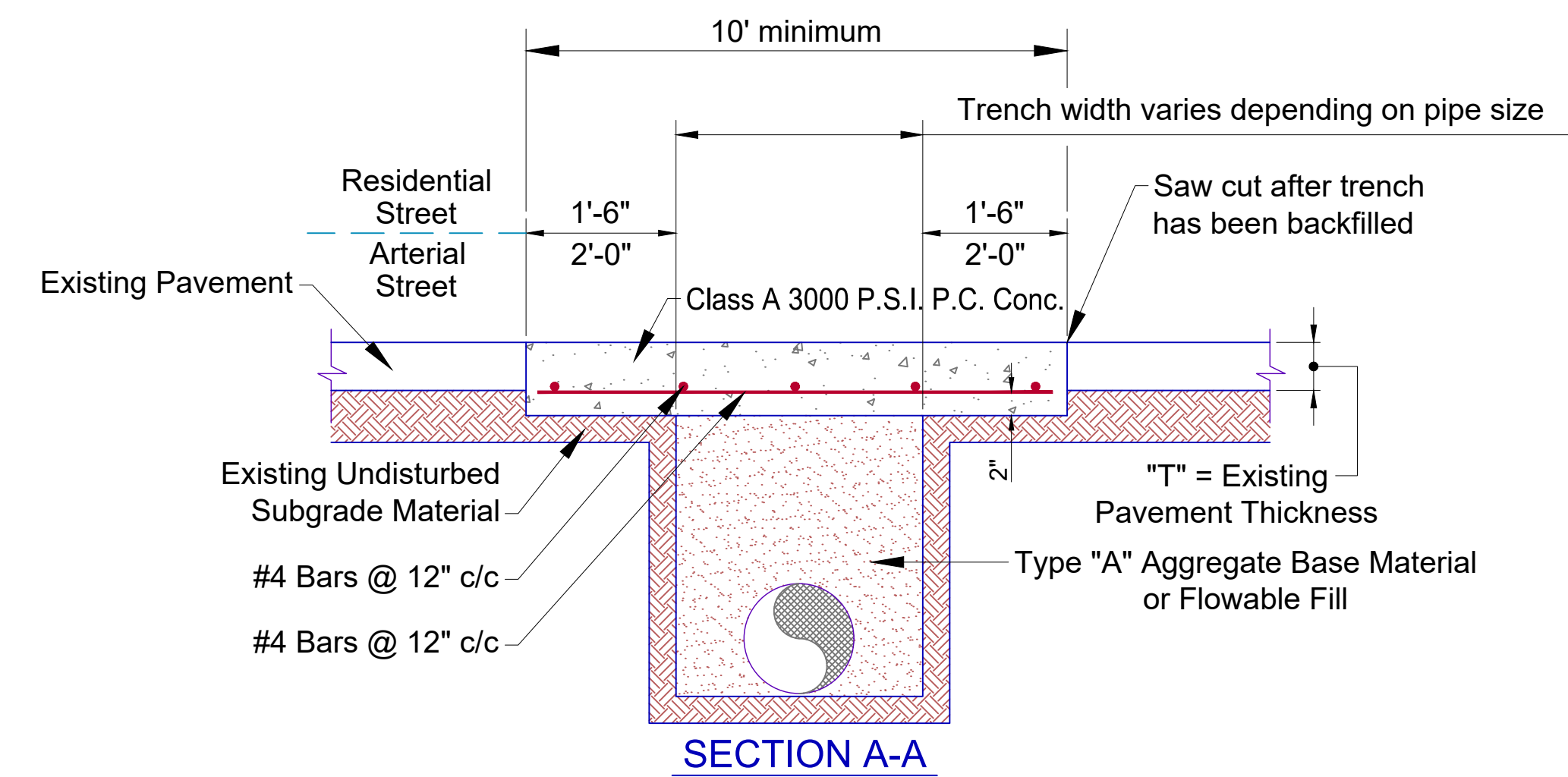

- 1 - Aggregate base to be compacted 95% Standard Proctor Density in 6" lifts.
- 2 - For repair in a concrete street, full panel replacement will be required.
- 3 - Thickness of repair shall be "T" + 2", but shall not be less than 10 inches.
- 4 - All cost of saw cut, removal and placement of compacted back fill to be included in price bid per square yard of repair unless otherwise stated in the contract documents.
- 5 - For longitudinal repair, concrete cap must be full lane width. If width of repair encroaches upon adjacent lane, repair of adjacent lane width will also be required.
- 6 - All sawcuts must be parallel with or perpendicular to the centerline of the pavement.

TYPICAL PERMANENT PAVING CUT REPAIR SECTION FOR CITY STREET

TRANSVERSE REPAIR PLAN VIEW

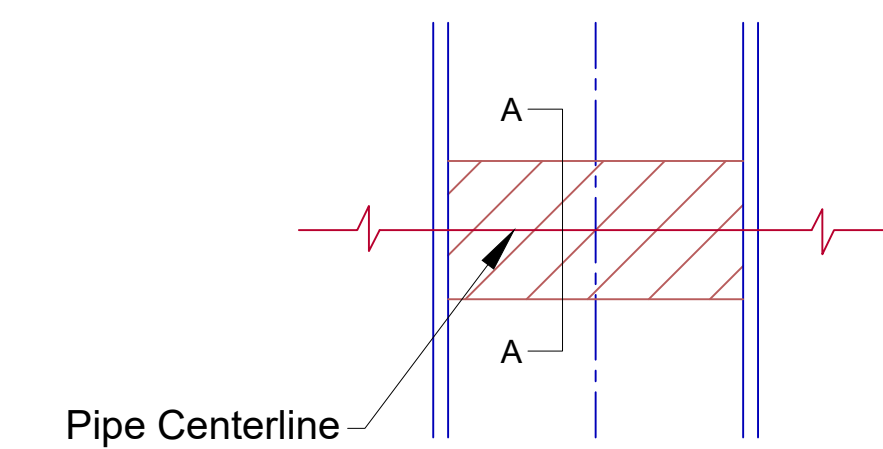

DIAGONAL REPAIR PLAN VIEW

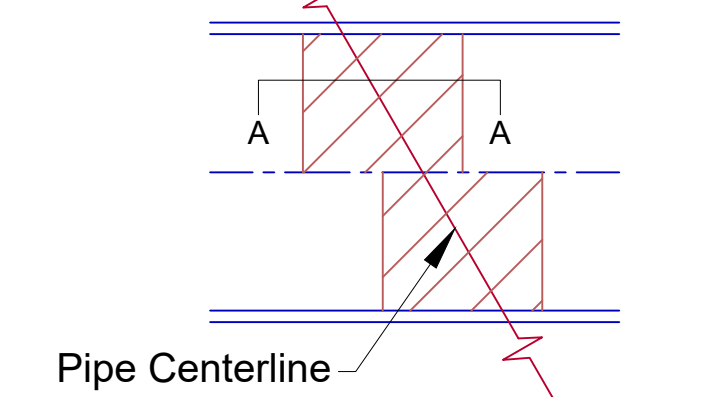

LONGITUDINAL REPAIR PLAN VIEW

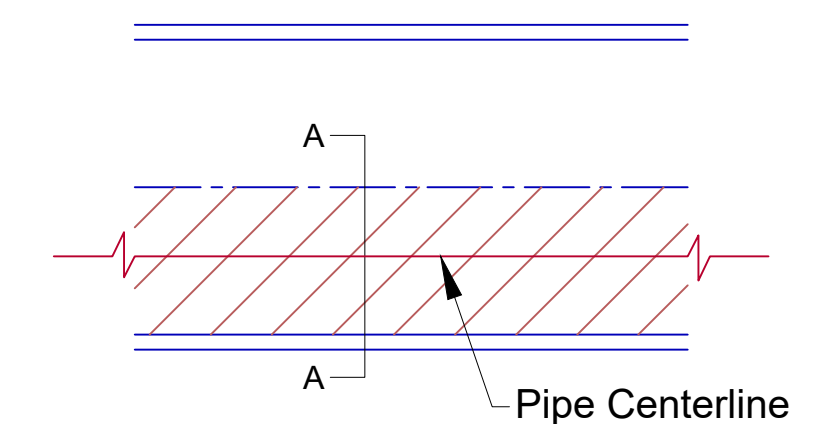

C:\Users\conmor.holland\OneDrive - City of Oklahoma City\Projects\Active\Standard Details\C3D\Drawings\800_DRAFT_Combined.dwg, 6/9/2026 8:07:30 AM

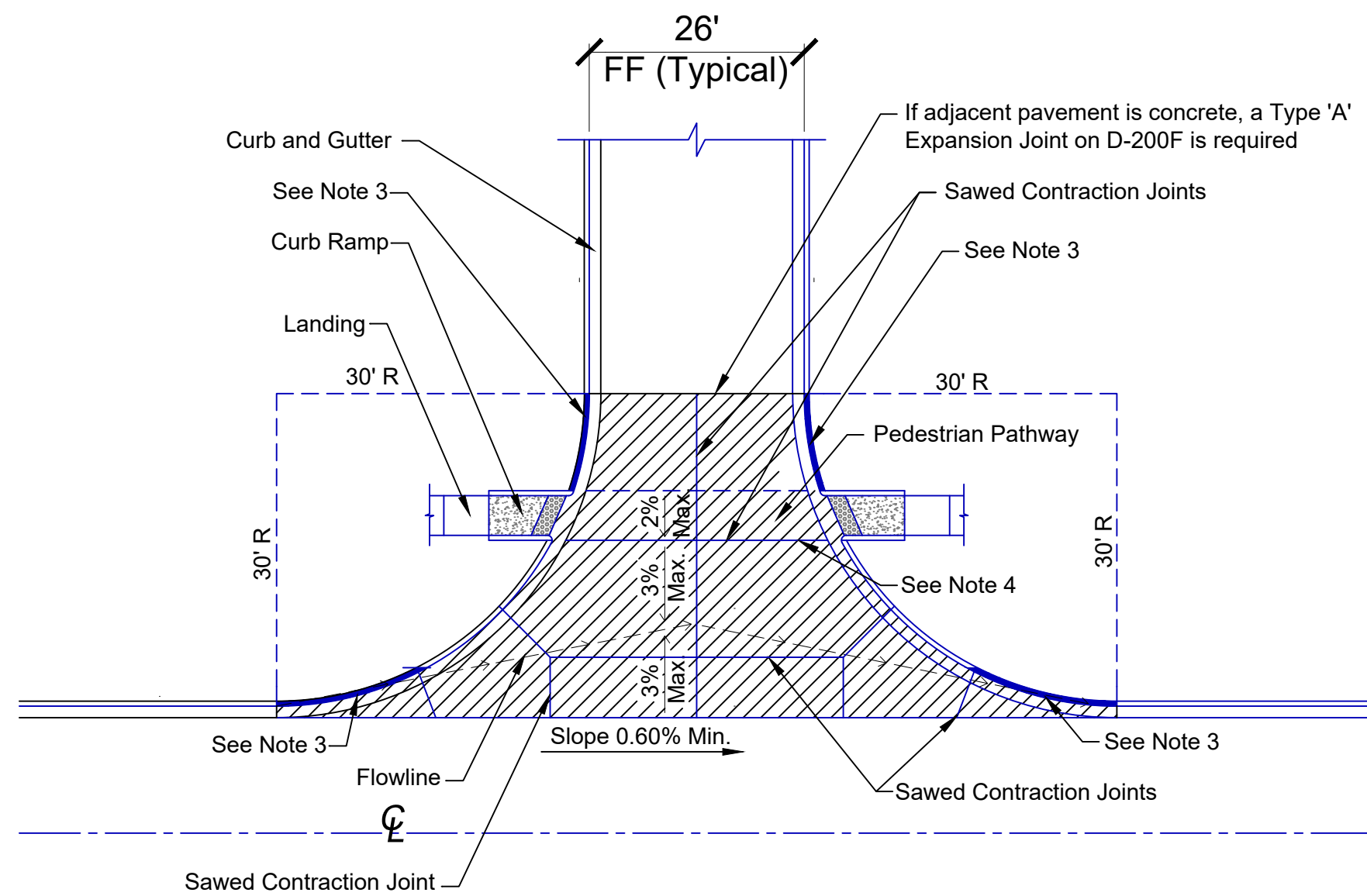

**OPTION 1
CONCRETE VALLEY GUTTER**

FOR ASPHALT PAVED STREETS
122.2 sy (typical) not included curb and gutter

NOTES:

1. Use Class A 3000 psi concrete, 8" Thick
2. Rebar #4 @ 12" CC.
3. Remove and replace 6' to 8' of existing curb and gutter. Replace entire curb and gutter radius if in poor condition.
4. Max spacing of sawed transverse construction joints to be 11' depending on location of pedestrian pathway

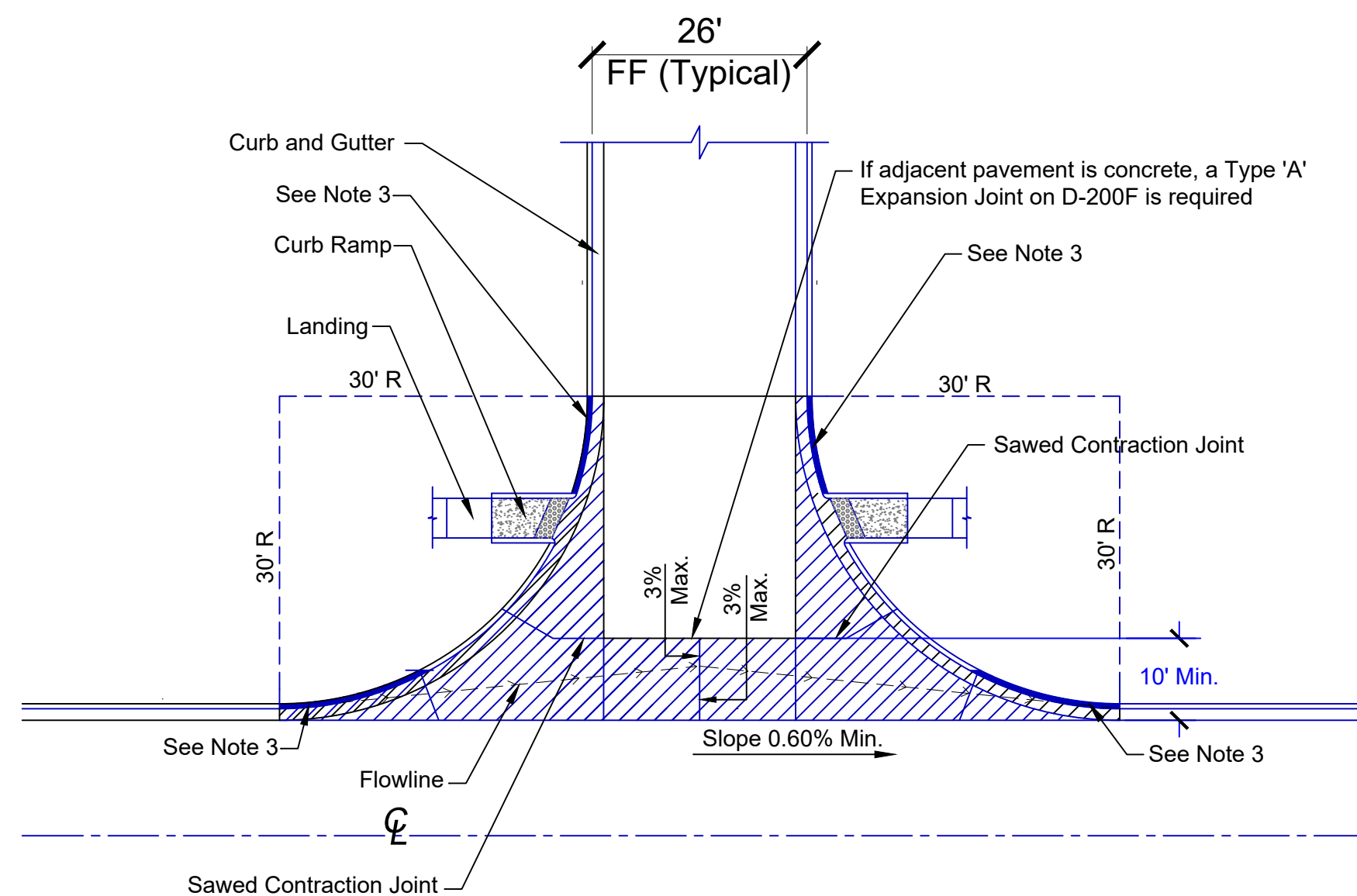

**OPTION 2
CONCRETE VALLEY GUTTER**

FOR ASPHALT PAVED STREETS
73.3 sy (typical) not included curb and gutter

NOTES:

1. Use Class A 3000 psi concrete, 8" Thick.
2. Rebar #4 @ 12" CC.
3. Remove and replace 6' to 8' of existing curb and gutter. Replace entire curb and gutter radius if in poor condition.

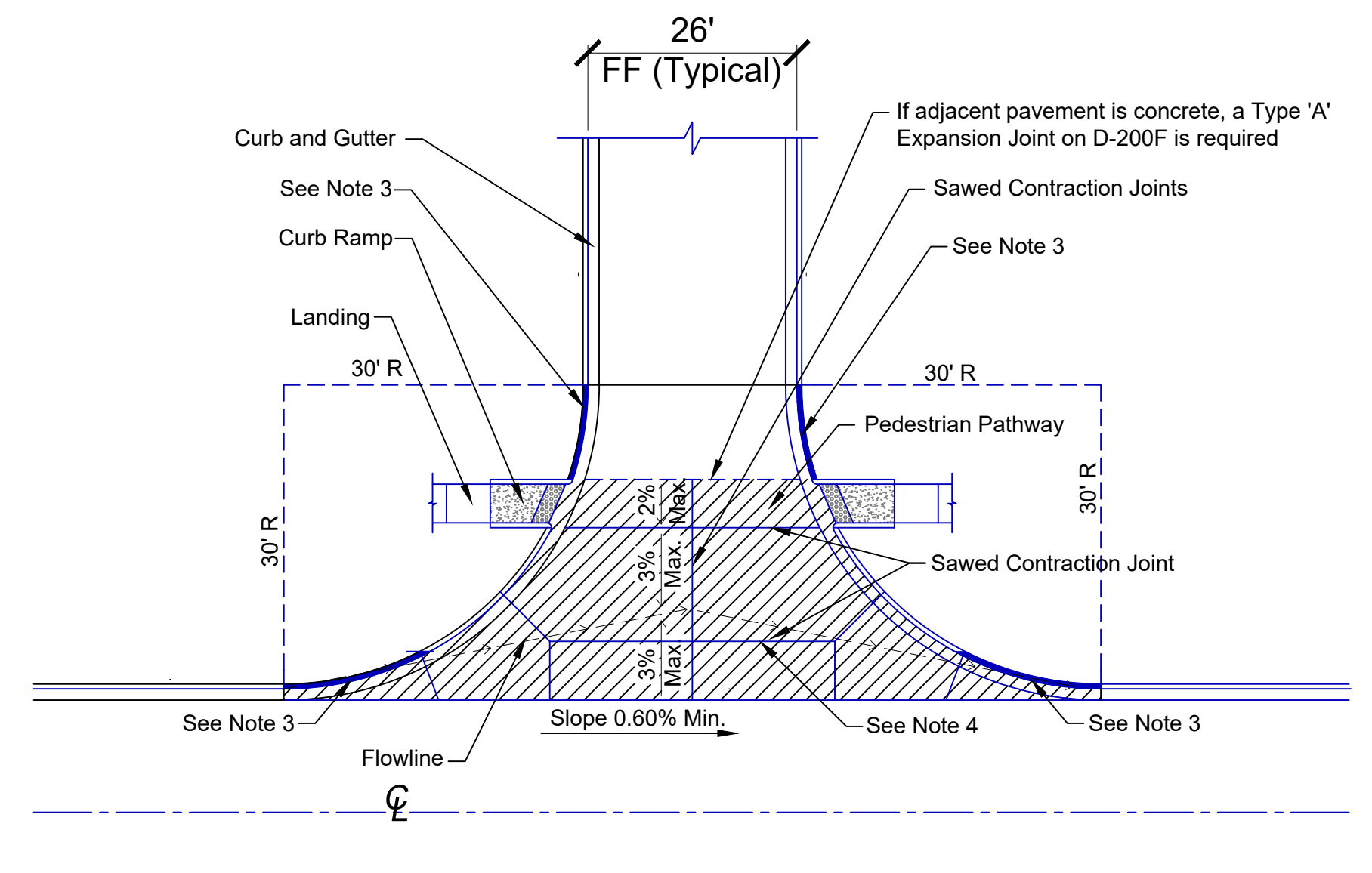

**OPTION 3
CONCRETE VALLEY GUTTER**

FOR ASPHALT PAVED STREETS
91.8 sy (typical) not including curb and gutter

NOTES:

1. Use Class A 3000 psi concrete, 8" Thick.
2. Rebar #4 @ 12" CC.
3. Remove and Replace 6' to 8' of Existing Curb and Gutter. Replace entire Curb and Gutter Radius if in Poor Condition.
4. Max spacing of sawed transverse construction joints to be 11' depending on location of pedestrian pathway

**DETAILS FOR SIDEWALK
LOCATED AT CURB**

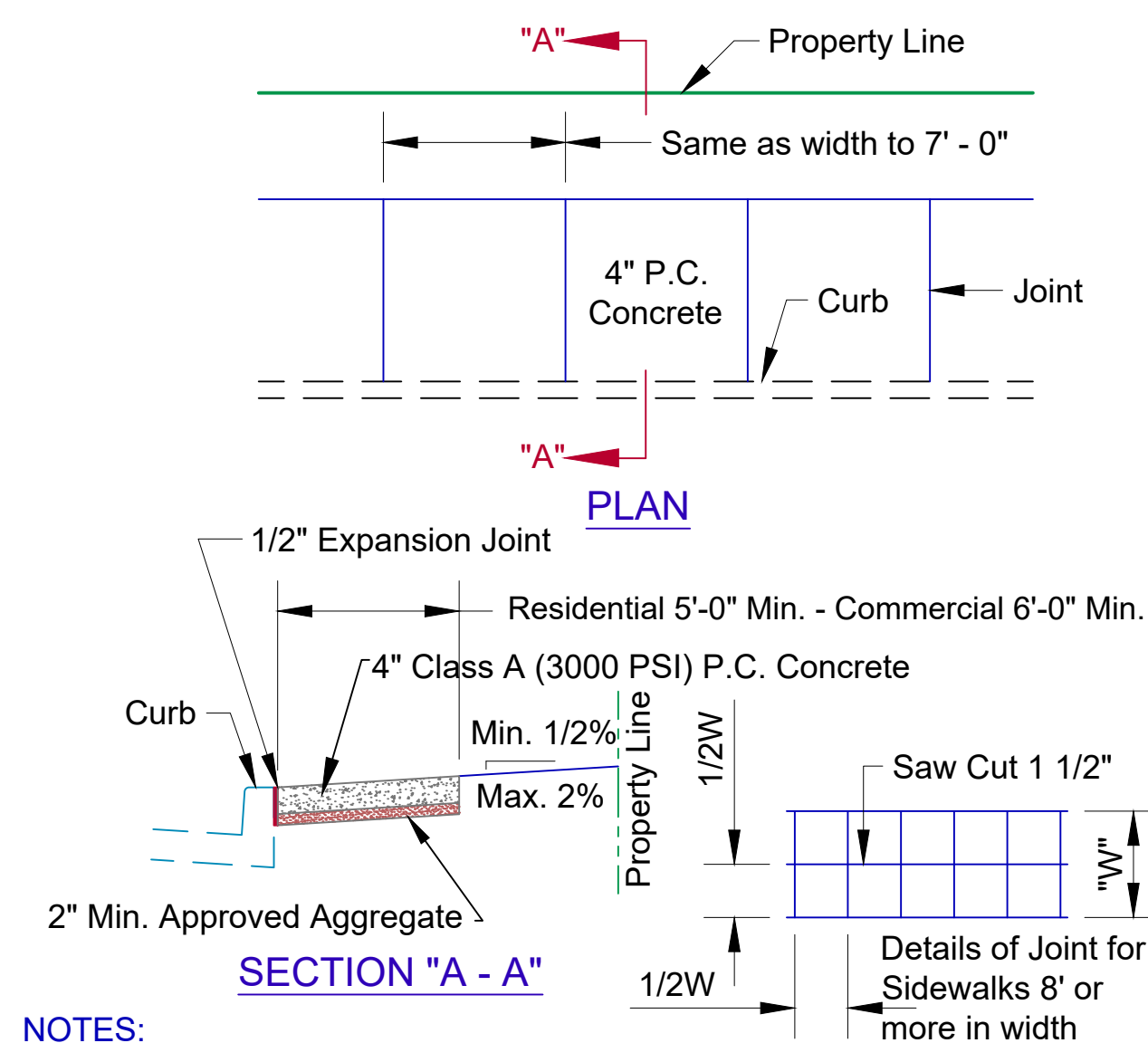

NOTES:

1. Place 1/2" x 4" premolded expansion material around Power Poles or other structures in walk, with at least 36" of clear travel space.
2. Expansion joints maximum distance = 200', use 1/2" x 4" premolded expansion material.
3. Transverse contraction joints maximum distance = 5', saw cut or Tool 1 1/4" deep.
4. Saw cut joints within 24 hours or 12 hours if temperature is above 85°F.
5. Use 1/2" x 4" premolded expansion joint behind curb or attached to curb.
6. Medium broom finish (transverse).
7. Use edger tool on all edges.

**DETAILS FOR SIDEWALK
LOCATED AWAY FROM CURB**

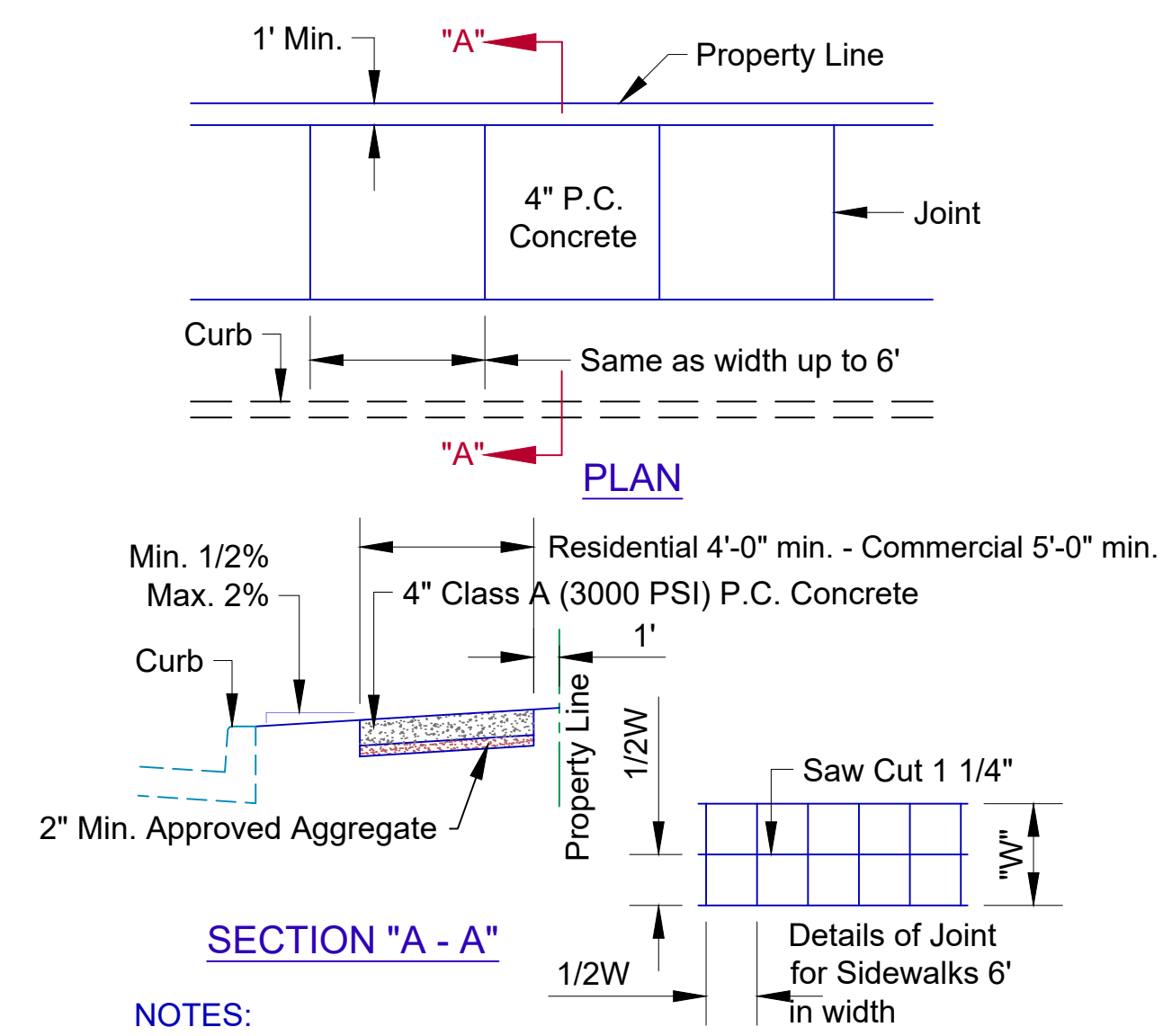

NOTES:

1. Place 1/2" x 4" premolded expansion material around Power Poles or other structures in walk, with at least 36" of clear travel space.
2. Expansion joints maximum distance = 200', use 1/2" x 4" premolded expansion material.
3. Transverse Contraction joints maximum distance = 5', saw cut or tool 1 1/4" deep.
4. Saw cut joints within 24 hours or 12 hours if temperature is above 85°F.
5. Medium broom finish (transverse).
6. Use edger tool on all edges.

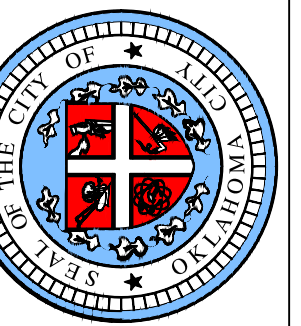

APPROVED BY: *Debbie Miller* DATE: 6/15/26
CITY ENGINEER

DRAWN: CH DATE: 06-09-26

STANDARD DETAILS

Note:

- The manhole frame shall be set to grade and concrete collar poured after surfacing operations. Existing ring and lid must be replaced with Deeter Foundry, Inc., shown on drawing number 1197-0110 and 1197-2100 respectively, or approved equal. The top of the ring and lid must match exactly the existing pavement grade, both longitudinally and transversely.
- Concrete collar shall be Class A 3000 PSI P.C. Concrete (2000 PSI in 24 hours). Concrete must be thoroughly vibrated. Contractor must call for inspection for verification of structure & dimensions before placing concrete.
- The work shall be protected by barriers and lights meeting MUTCD and shall not be removed for a period of 24 hours after the pour is made.
- Subgrade outside the limits of the manhole cone, must be compacted with mechanical compactor before placing concrete. The subgrade must be firm and unyielding.
- All excavation at the corners of the concrete collar must be removed so that it is a minimum of 8" thick for the full extent of the collar.
- Place one #5 reinforcing steel diagonal at each corner 4" from the edge of the manhole ring.

ADJUSTMENT OF MANHOLE TO GRADE

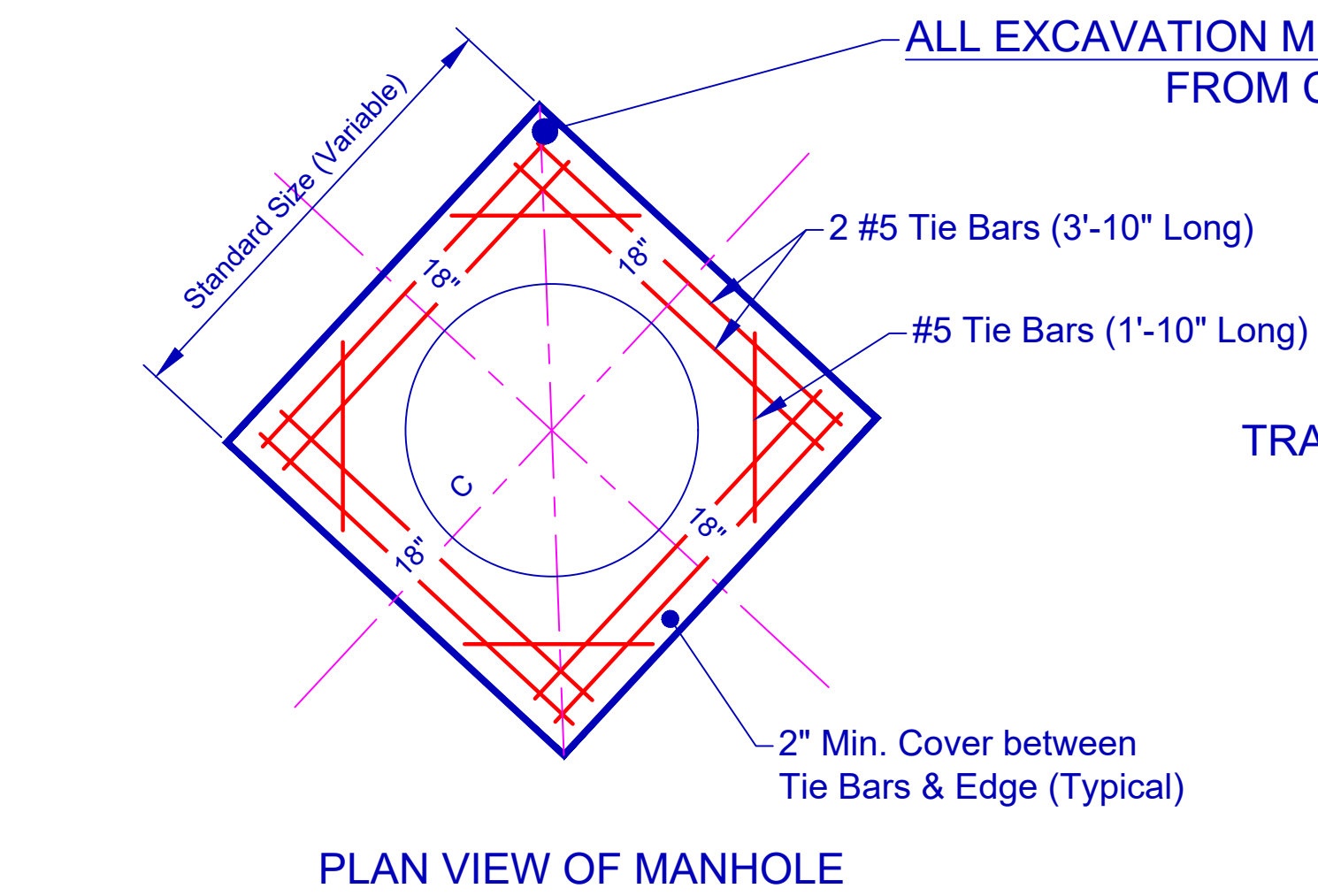

PLAN VIEW OF MANHOLE

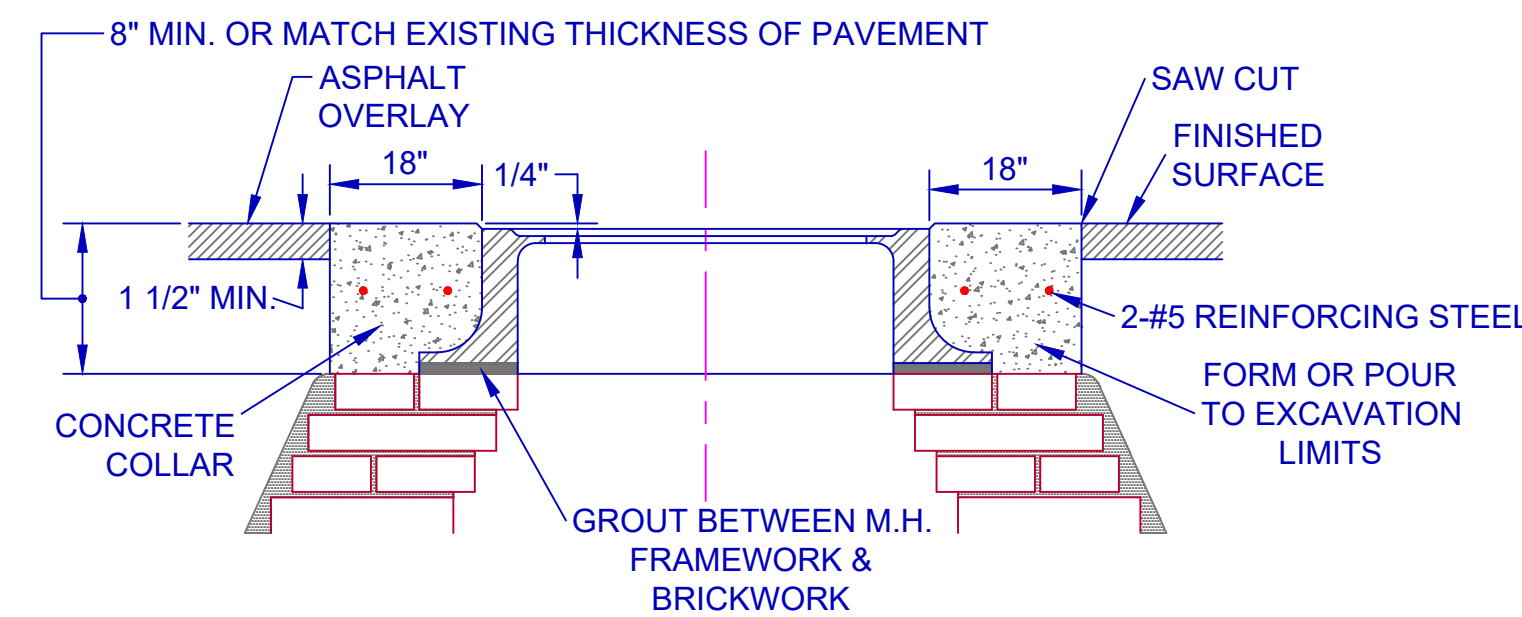

ADJUSTMENT OF VALVE BOX TO GRADE

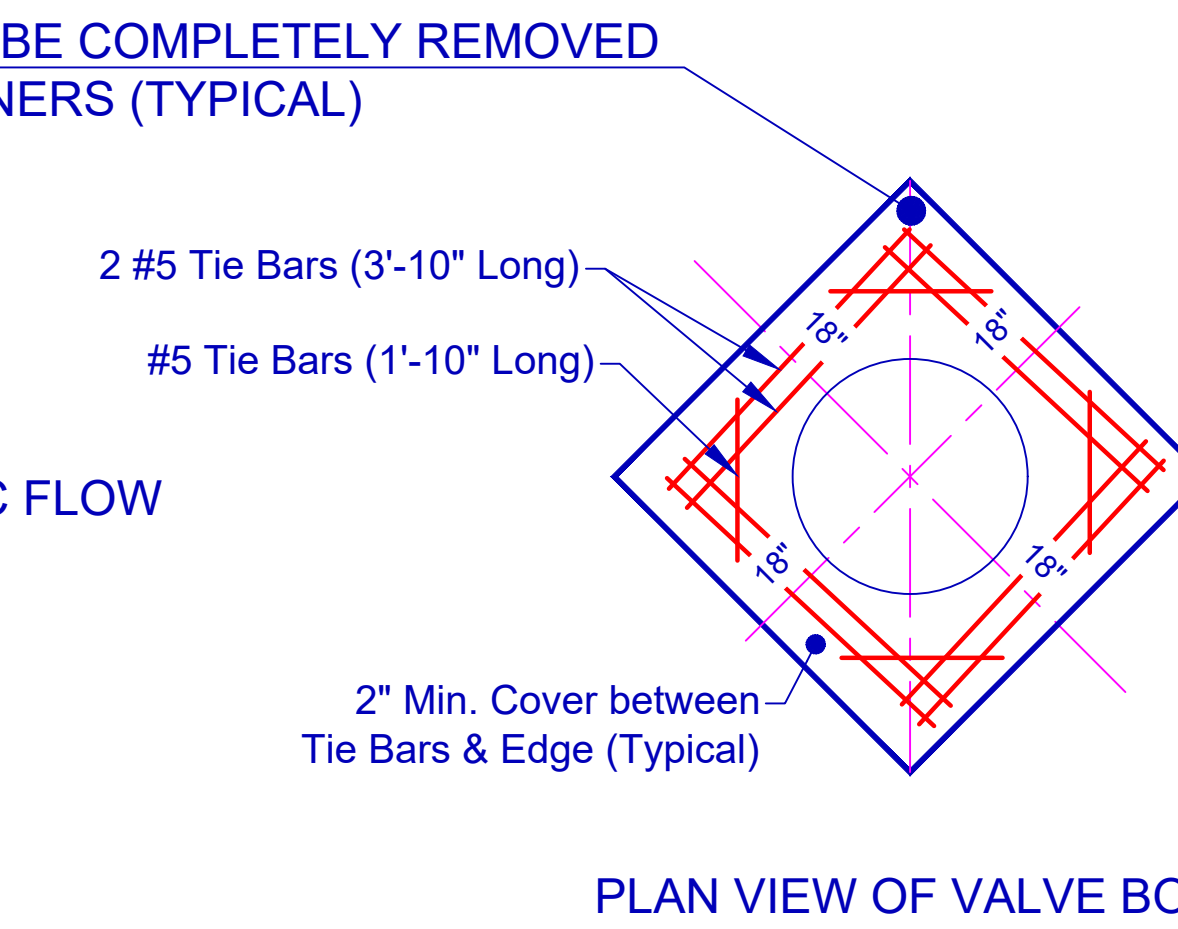

PLAN VIEW OF VALVE BOX

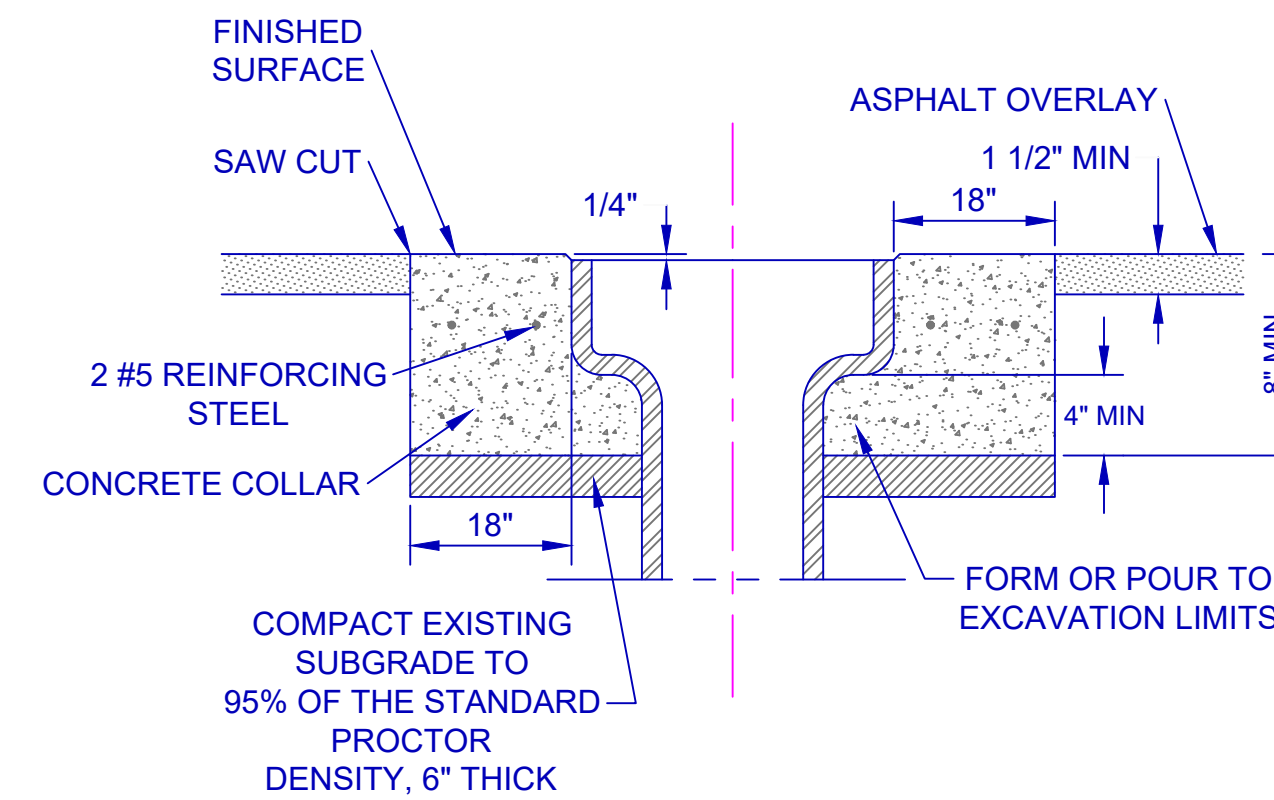

EXTENSION OF COLLAR BOX

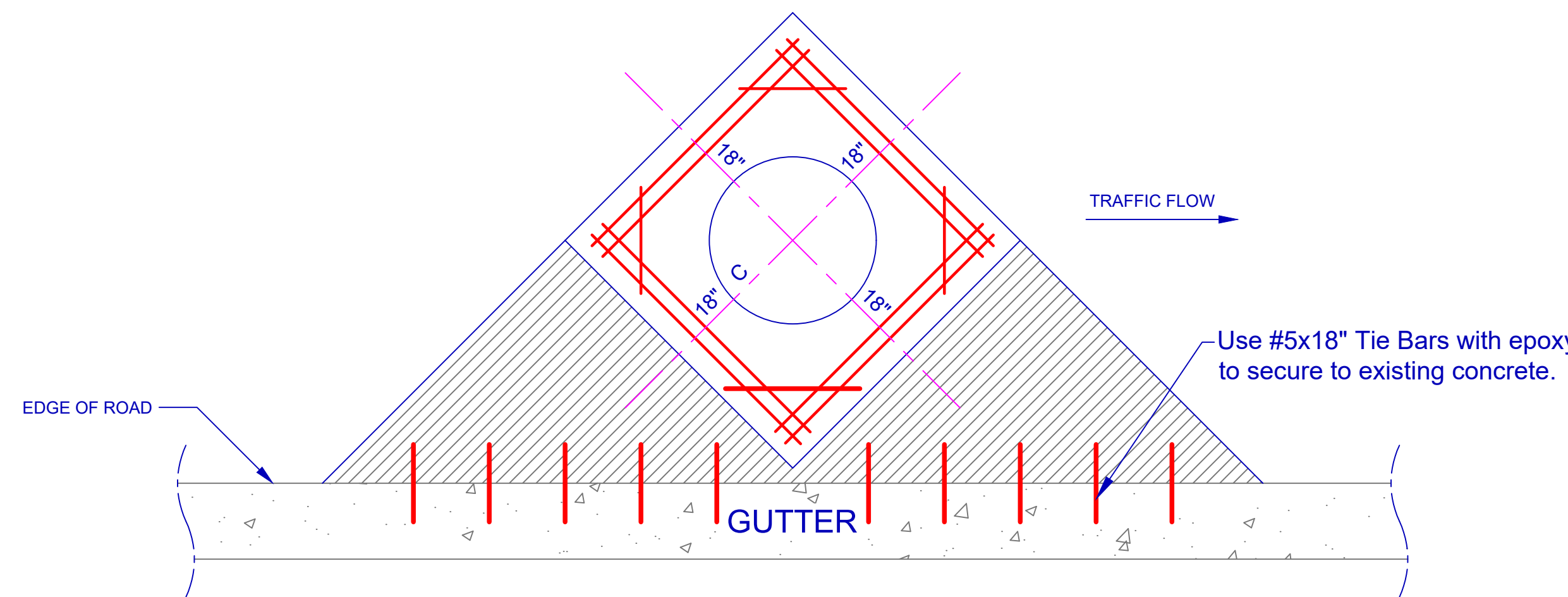

Note

If edge of concrete collar is 18 inches or less from existing curb and gutter then this detail shall apply.

Note:

- The valve box shall be set to grade and concrete collar poured after resurfacing operations. The top of the valve box must match exactly the existing pavement grade, both longitudinally and transversely.
- Concrete base shall be Class A 3000 PSI P.C. Concrete (2000 PSI in 24 hours). Concrete must be thoroughly vibrated. Contractor must call for inspection for verification of structure & dimensions before placing concrete.
- The work shall be protected by barriers and lights meeting MUTCD and shall not be removed for a period of 24 hours after the pour is made.
- Subgrade outside the limits of the manhole cone, must be compacted with mechanical compactor before placing concrete. The subgrade must be firm and unyielding.
- All excavation at the corners of the concrete collar must be removed so that it is a minimum of 8" thick for the full extent of the collar.
- Place one #5 reinforcing steel diagonal at each corner 4" from the edge of the valve box.

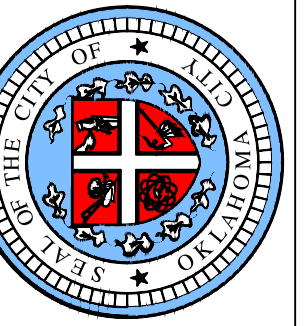

APPROVED BY: *Debbie Miller*
DATE: 6/15/26
CITY ENGINEER
DRAWN: CH
DATE: 06-09-26

STANDARD DETAILS

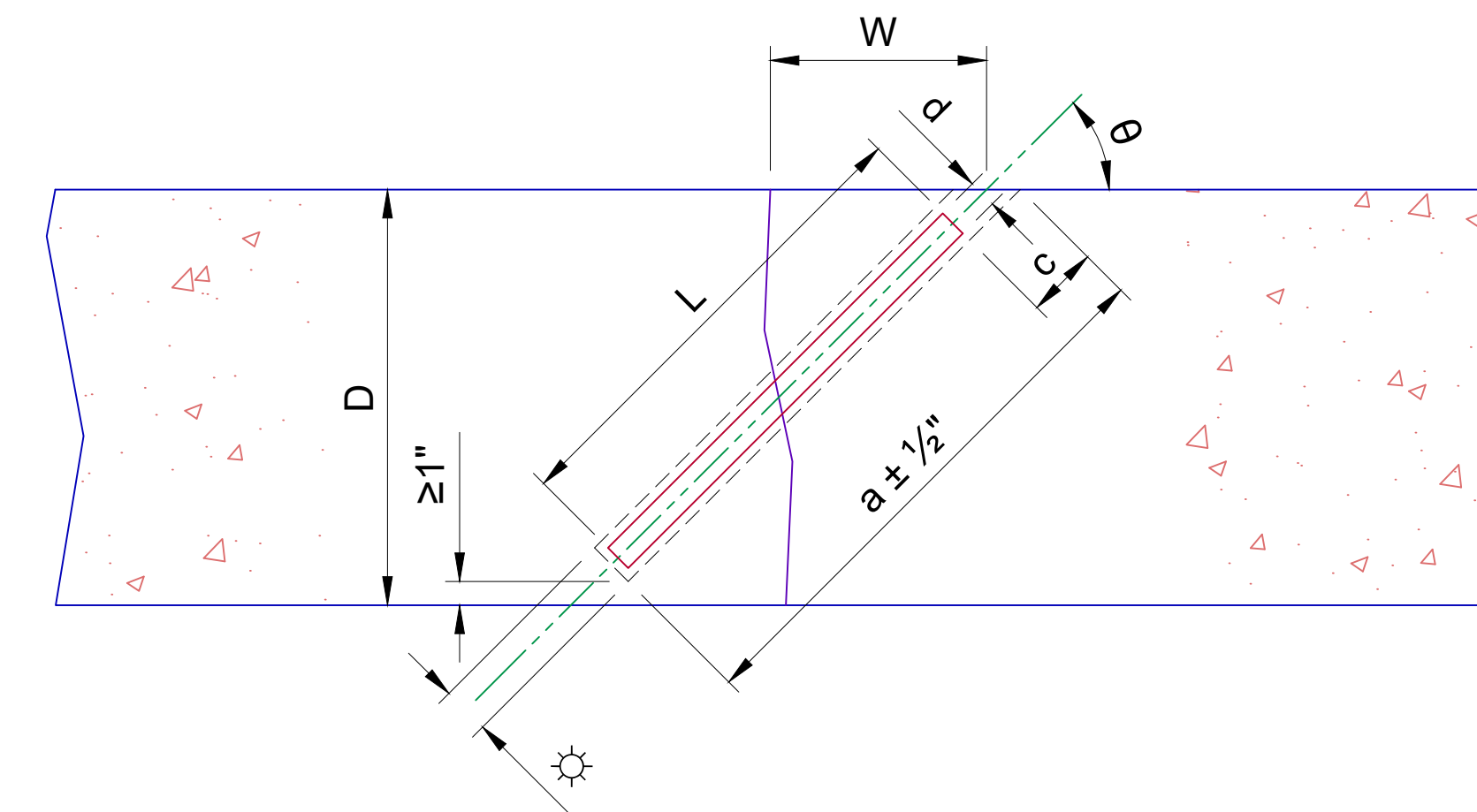
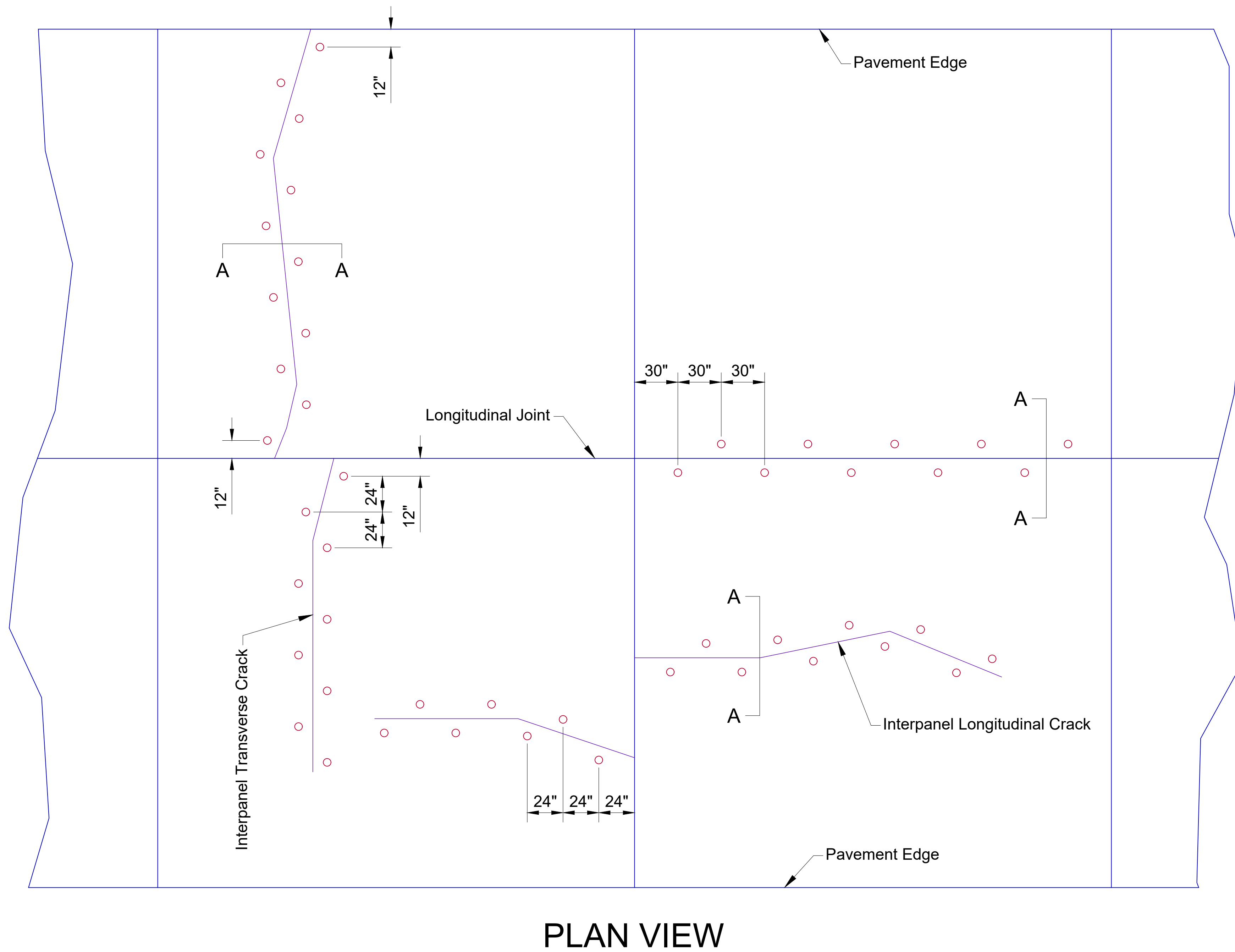

☼ Drill diameter will be not less than 1/4" larger than the tie bar diameter and no more than 3/8" larger than the tie bar diameter.

DIMENSIONS FOR TIE BAR INSERTION						
Slab Thickness D (in.)	Angle θ (deg.)	Offset W (in.)	Bar Diameter d (in.)	Length of Bar L (in.)	Depth of Hole a (in.)	Min. Depth to Bar c (in.)
8.00	35	5.75	0.75	9.00	11.50	2.25
8.50	35	6.00	0.75	9.50	12.25	2.25
9.00	35	6.50	0.75	10.50	13.25	2.25
9.50	35	6.75	0.75	11.50	14.00	2.25
10.00	40	6.00	0.75	11.00	13.25	2.00
10.50	40	6.25	0.75	12.00	14.25	2.00
11.00	40	6.50	0.75	12.50	15.00	2.00
11.50	40	6.75	0.75	13.50	15.75	2.00
12.00	45	6.00	0.75	13.00	15.00	1.75
12.50	45	6.25	0.75	13.50	15.75	1.75
13.00	45	6.50	1.00	14.00	16.25	2.00
13.50	45	6.75	1.00	14.50	17.00	2.00
14.00	45	7.00	1.00	15.50	17.75	2.00
14.50	45	7.25	1.00	16.00	18.50	2.00
15.00	45	7.50	1.00	17.00	19.25	2.00

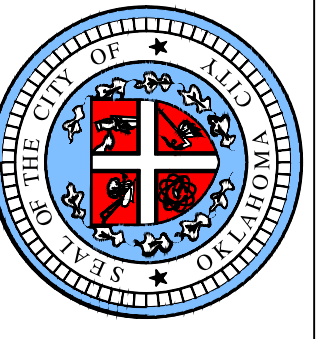

APPROVED BY: *Debbie Miller* DATE: 6/15/26
CITY ENGINEER
DRAWN: CH DATE: 06-09-26

CROSS-STITCHING TIE BAR
INSERTION